



C925

Maintenance Guide

Contents

Maintaining the printer.....	3
Cleaning the exterior of the printer.....	3
Cleaning the printhead lenses.....	3
Storing supplies.....	6
Checking the status of supplies.....	6
Checking the status of supplies from the printer control panel.....	6
Checking the status of supplies from a network computer.....	7
Ordering supplies.....	7
Ordering toner cartridges.....	7
Ordering imaging units.....	8
Ordering a fuser or a transfer module.....	8
Ordering a waste toner bottle.....	8
Replacing Supplies.....	9
Replacing an imaging unit.....	9
Replacing a toner cartridge.....	11
Replacing the waste toner bottle.....	13
Moving the printer.....	15
Before moving the printer.....	15
Moving the printer to another location.....	15
Shipping the printer.....	15

Maintaining the printer

Cleaning the exterior of the printer

- 1 Make sure that the printer is turned off and unplugged from the wall outlet.



CAUTION—SHOCK HAZARD: To avoid the risk of electric shock when cleaning the exterior of the printer, unplug the power cord from the wall outlet and disconnect all cables to the printer before proceeding.

- 2 Remove paper from the standard exit bin.
- 3 Dampen a clean, lint-free cloth with water.

Warning—Potential Damage: Do not use household cleaners or detergents, as they may damage the finish of the printer.

- 4 Wipe only the outside of the printer, making sure to include the standard exit bin.

Warning—Potential Damage: Using a damp cloth to clean the interior may cause damage to your printer.

- 5 Make sure the paper support and standard exit bin are dry before beginning a new print job.

Cleaning the printhead lenses

- 1 Open the front door.

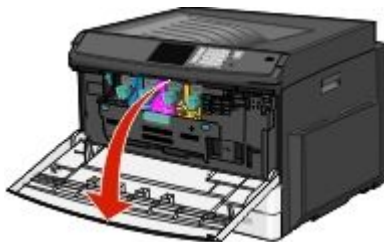

- 2 Turn the toner lock lever to the right and pull the toner cartridge out.

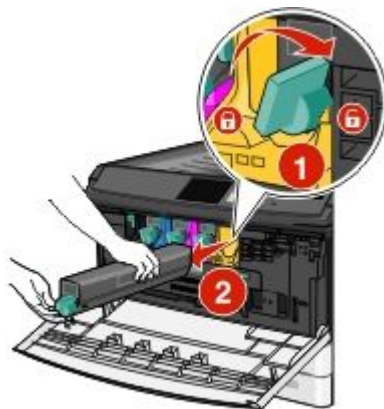

- 3** Remove the imaging unit:
a Open the internal cover.

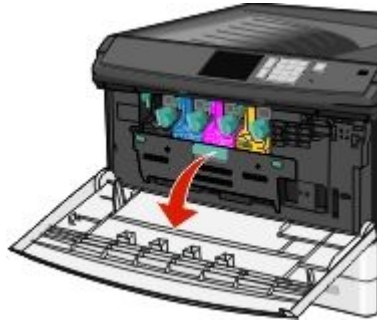

- b** Push the imaging unit lock lever up and pull out the imaging unit.

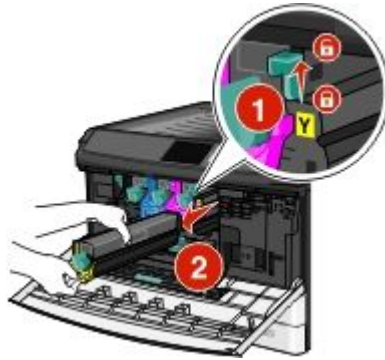

- 4** Locate the LED wipe at the end of the imaging unit. Make sure it is in the correct position.

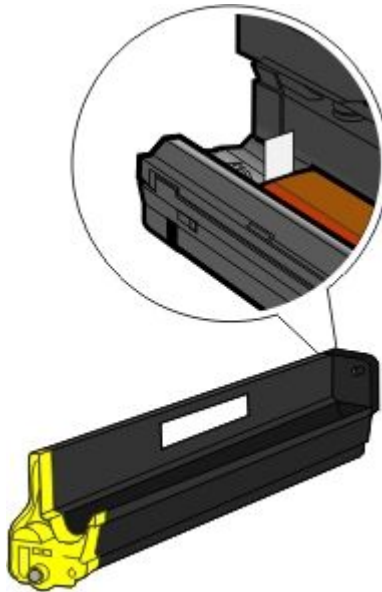

5 Reinstall the imaging unit. When inserted into the printer, the LED wipe will rub across the row of LEDs, thus cleaning the printhead lenses.

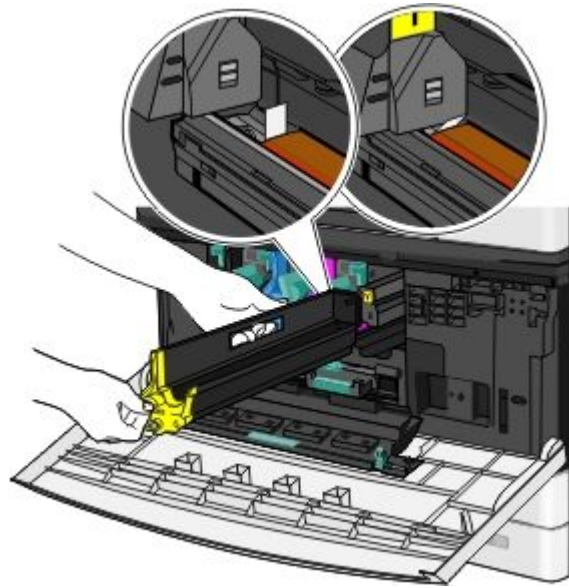

a Insert the imaging unit into the printer until it *clicks* into place.



b Using both hands, push the sides of the internal cover firmly until the cover *clicks* into place.

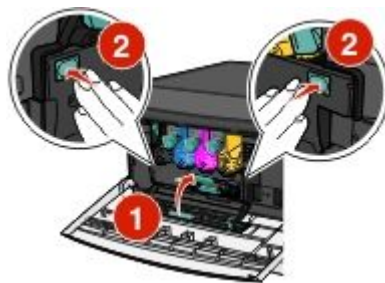

6 Insert the toner cartridge into the printer and then turn the toner lock lever to the left.

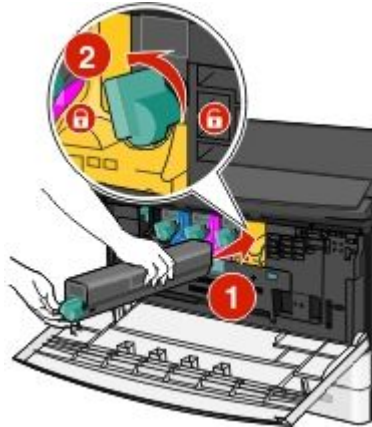

7 Repeat step 2–6 to for all imaging units.

8 Close the front door.

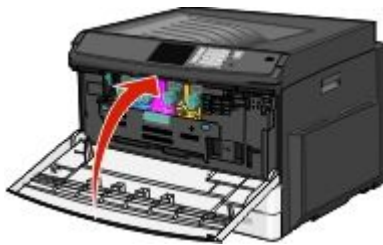

Storing supplies

Choose a cool, clean storage area for the printer supplies. Store supplies right side up in their original packing until you are ready to use them.

Do not expose supplies to:

- Direct sunlight
- Temperatures above 35°C (95°F)
- High humidity above 80%
- Salty air
- Corrosive gases
- Heavy dust

Checking the status of supplies

Checking the status of supplies from the printer control panel

From the home screen, touch **Status/Supplies** > **View Supplies**.

Checking the status of supplies from a network computer

Note: The computer must be connected to the same network as the printer.

- 1 Type the printer IP address into the address field of your Web browser.

If you do not know the IP address of the printer, you can:

- View the IP address on the printer control panel in the TCP/IP section under the Networks/Ports menu.
- Print a network setup page or the menu settings pages and locate the IP address in the TCP/IP section.

- 2 Click **Device Status**.

The Device Status page appears, displaying a summary of supply levels.

Ordering supplies

To order supplies in the U.S., contact Lexmark at 1-800-539-6275 for information about Lexmark authorized supplies dealers in your area. In other countries or regions, visit the Lexmark Web Site at www.lexmark.com or contact the place where you purchased the printer.

Note: All life estimates for printer supplies assume printing on letter- or A4-size plain paper.

Ordering toner cartridges

When **88.xx [color] cartridge low**, or **88.xx [color] cartridge nearly low** appears, order a new cartridge.

When **88.2x Replace [color] cartridge** appears, replace the specified cartridge.

Estimated cartridge yield is based on the ISO/IEC 19798 standard (with about 5% coverage per color). Extremely low print coverage (less than 1.25% for a color) for extended periods of time may negatively affect actual yield for that color and may cause cartridge parts to fail prior to exhaustion of toner.

Recommended toner cartridges and part numbers

Part name	Part number
Black high-yield toner cartridge	C925H2KG
Yellow high-yield toner cartridge	C925H2YG
Magenta high-yield toner cartridge	C925H2MG
Cyan high-yield toner cartridge	C925H2CG

Ordering imaging units

When **84.xx [Color] imaging unit low**, or **84.xx [Color] imaging unit nearly low** appears, order a replacement imaging unit.

When **84.xx Replace [color] imaging unit and [color] cartridge** appears, replace the specified imaging unit and toner cartridge.

Recommended imaging units and part numbers

Part name	Part number
Black imaging unit	C925X72G
Yellow imaging unit	C925X75G
Magenta imaging unit	C925X74G
Cyan imaging unit	C925X73G

Ordering a fuser or a transfer module

When **80.xx Fuser life warning**, **80.xx Fuser near life warning**, or **83.xx Transfer module life warning** appears, order a replacement fuser or a transfer module.

When **80.xx Replace fuser** or **83.xx Replace transfer module** appears, install the new fuser or the new transfer module. For installation information, see the documentation that came with the part.

Part name	Part number
Fuser	40X6013 (110 volts) 40X6093 (220 volts)
Transfer module	40X6011

Ordering a waste toner bottle

When **82.xx Waste toner bottle nearly full** appears, order a replacement waste toner bottle.

When **82.xx Replace waste toner bottle** appears, replace the waste toner bottle.

Note: Waste toner bottle reuse is not recommended.

Part name	Part number
Waste toner bottle	C925X76G

Replacing Supplies

Replacing an imaging unit

- 1 Open the front door.



Warning—Potential Damage: To avoid overexposing the imaging units, do not leave the door open for more than 10 minutes.

- 2 Open the internal cover.

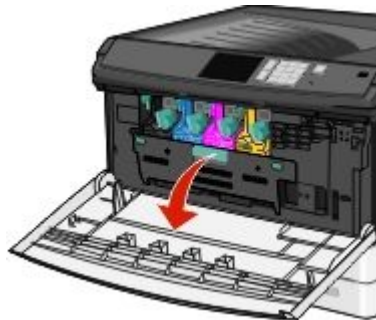

- 3 Push the imaging unit lock lever up and pull out the imaging unit with the toner cartridge attached to it.

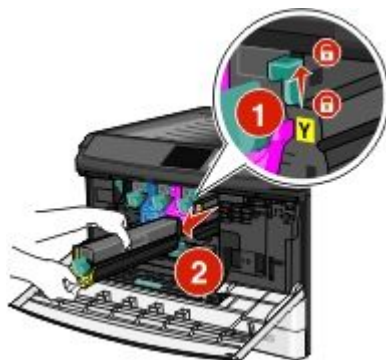

- 4 Unpack the replacement imaging unit.

5 Peel off the black protective sheet and the toner sealing tape.



6 Insert the imaging unit into the printer until it *clicks* it into place.



7 Using both hands, push the sides of the internal cover firmly until the cover *clicks* into place.



8 Unpack the toner cartridge, and then shake it to redistribute the toner.



9 Peel off the toner sealing tape.



10 Insert the toner cartridge and turn the lock lever to the left.

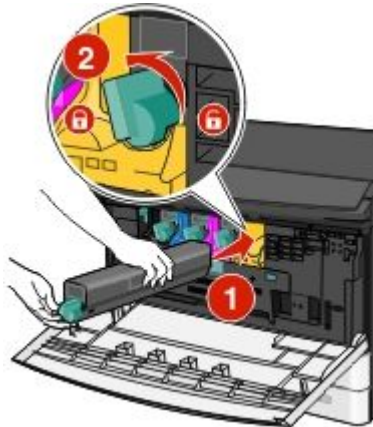

11 Close the front door.

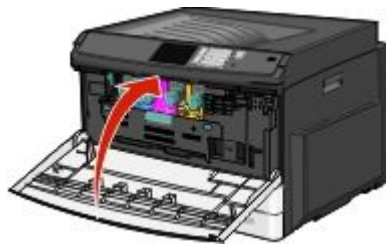

Replacing a toner cartridge

1 Open the front door.

Warning—Potential Damage: To avoid overexposing the imaging units, do not leave the door open for more than 10 minutes.

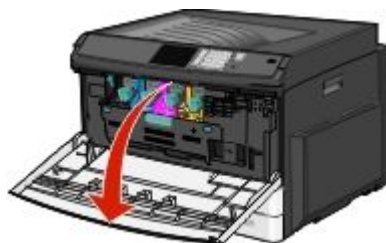

2 Turn the toner lock lever to the right and pull the toner cartridge out.



3 Unpack the toner cartridge, and then shake it to redistribute the toner.



4 Peel off the toner sealing tape.



5 Insert the new cartridge into the printer and then turn the toner lock lever to the left.

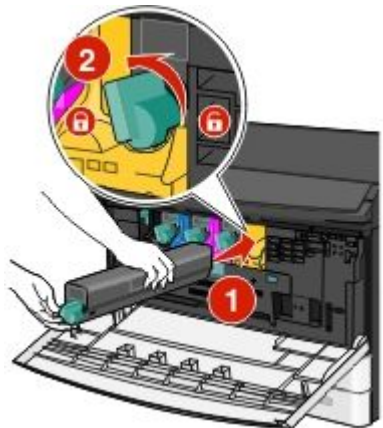

6 Close the front door.



Replacing the waste toner bottle

- 1 Turn the printer off.
- 2 Open the front door.

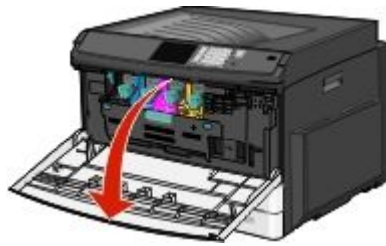

3 Open the internal cover.

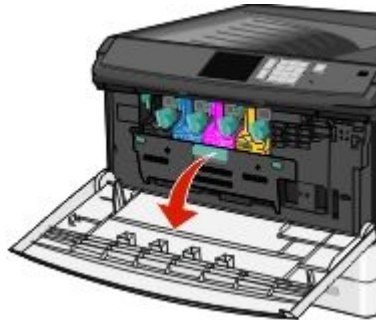

4 Pull out the used waste toner bottle.

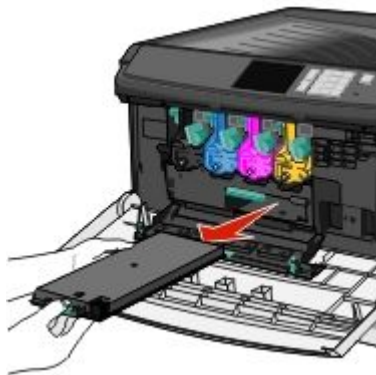

5 Unpack the new waste toner bottle.



6 Insert the new waste toner bottle into the printer.

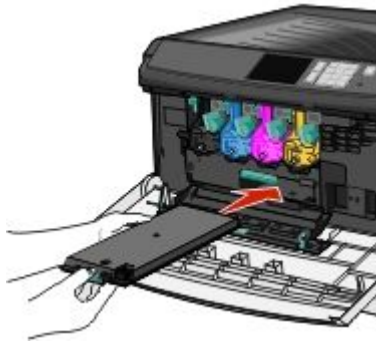

7 Using both hands, push the sides of the internal cover firmly until it *clicks* into place.



8 Close the front door.



9 From the printer control panel, reset the Waste Toner Bottle counter in the Supplies menu.

Moving the printer

Before moving the printer



CAUTION—POTENTIAL INJURY: The printer weight is greater than 18 kg (40 lb) and requires two or more trained personnel to lift it safely.



CAUTION—POTENTIAL INJURY: Before moving the printer, follow these guidelines to avoid personal injury or printer damage:

- Turn the printer off using the power switch, and then unplug the power cord from the wall outlet.
- Disconnect all cords and cables from the printer before moving it.
- Lift the printer off of the optional drawer and set it aside instead of trying to lift the drawer and printer at the same time.

Note: Use the handholds located on both sides of the printer to lift it off the optional drawer.

Warning—Potential Damage: Damage to the printer caused by improper moving is not covered by the printer warranty.

Moving the printer to another location

The printer and options can be safely moved to another location by following these precautions:

- Any cart used to move the printer must have a surface able to support the full footprint of the printer. Any cart used to move the options must have a surface able to support the dimensions of the options.
- Keep the printer in an upright position.
- Avoid severe jarring movements.

Shipping the printer

When shipping the printer, use the original packaging or call the place of purchase for a relocation kit.