

Lexmark™ C935

Clearing Jams Guide

Clearing jams

Avoiding jams

The following hints can help you avoid jams:

- Use only recommended paper or specialty media.
For more information, see the *Card Stock & Label Guide* available on the Lexmark Web site at www.lexmark.com/publications.
- Do not load too much paper. Make sure the stack height does not exceed the indicated maximum height.
- Do not load wrinkled, creased, damp, or curled paper.
- Flex, fan, and straighten paper before loading it.
- Do not use paper that has been cut or trimmed by hand.
- Do not mix paper sizes, weights, or types in the same stack.
- Store the paper in an appropriate environment.
- Do not remove trays while the printer is printing. Wait for **Load tray <x>** or **Ready** to appear before removing a tray.
- Do not load the manual feeder while the printer is printing. Wait for **Load Manual feeder with <x>** to appear.
- Push all trays in firmly after loading paper.
- Make sure the guides in the trays are properly positioned, and are not pressing too tightly against the paper.
- Make sure all paper sizes and paper types are set correctly in the control panel menu.
- Make sure all printer cables are attached correctly. For more information, see the setup documentation.

Understanding jam numbers and locations

When a jam occurs, a message indicating the jam location appears. The following illustration and table list the paper jams that can

occur and the location of each jam. Open doors and covers, and remove trays to access jam locations.

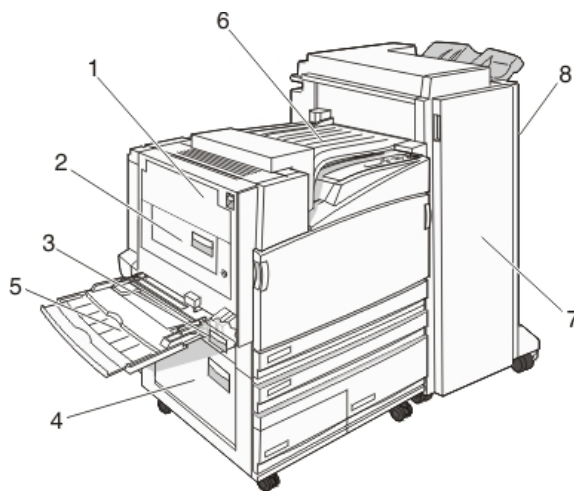

	Jam numbers	Area name	Instructions
1	200–203	Door A	Open Door A, and then remove the jam.
2	230–231	Door B	Open Doors A and B, and then remove any jams.
3	241	Door C	Open Door C, and then remove the jam. Open Tray 1, and then remove the jam.
4	242–244	Door D	Open Door D, and then remove the jam. Open Trays 2–4, and then remove any jams.

	Jam numbers	Area name	Instructions
5	250	Multipurpose feeder	<ol style="list-style-type: none"> 1 Remove all paper from the multipurpose feeder. 2 Flex and stack the paper. 3 Reload the multipurpose feeder. 4 Adjust the paper guides.
6	280–282	Cover F (Horizontal Transport Unit)	Open Cover F, and then remove the jam.
7	283–284 287–288 289	Door G	Open Door G, and then remove the jam. For staple jams, remove the sheets in the accumulator. Remove the staple cartridge, and then clear the staple jam.
8	284–286	Door H	Open Door H, and then remove the jam. Note: Door H is located between the finisher output bins.

200–203 paper jams

- 1 Open Door A by lifting the release latch and lowering the door.



CAUTION—HOT SURFACE: The inside of the printer might be hot. To reduce the risk of injury from a hot component, allow the surface to cool before touching.

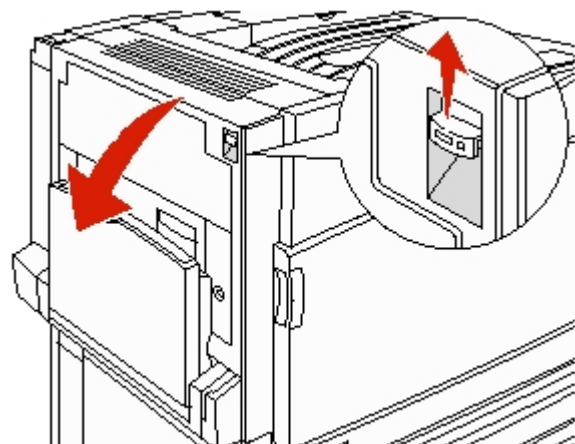

2 Lift the green lever, and then pull the paper up and toward you.

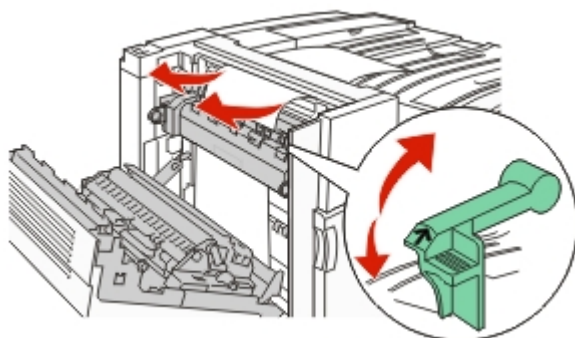

Note: Make sure all paper fragments are removed.

- 3 Push the green lever down.
- 4 Close Door A.
- 5 Press .

230–231 paper jams

- 1 Open Door A by lifting the release latch and lowering the door.



CAUTION—HOT SURFACE: The inside of the printer might be hot. To reduce the risk of injury from a hot component, allow the surface to cool before touching it.

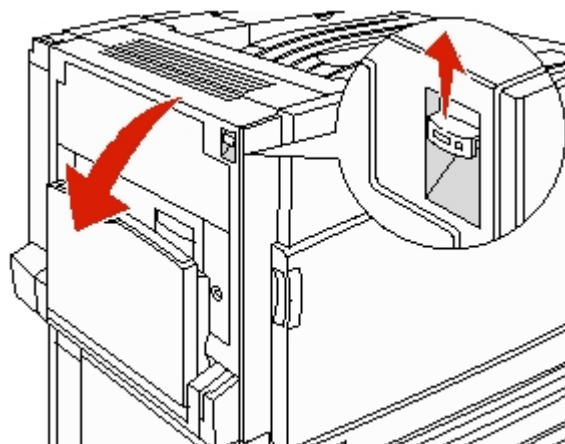

2 Lift the green lever, and then pull the paper up and toward you.

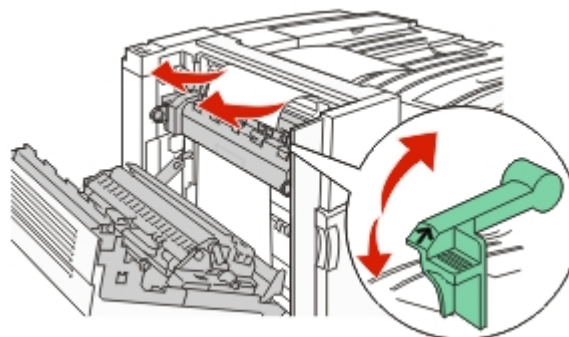

Note: Make sure all paper fragments are removed.

- 3 Push the green lever down.
- 4 Close Door A.

5 Pull the multipurpose feeder down, and then open Door B.

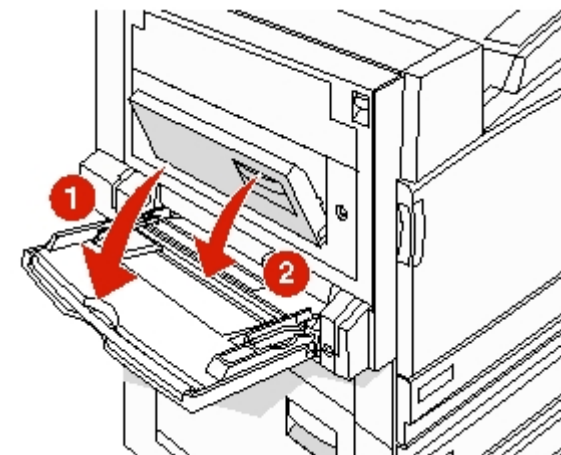

6 Remove the jammed paper.

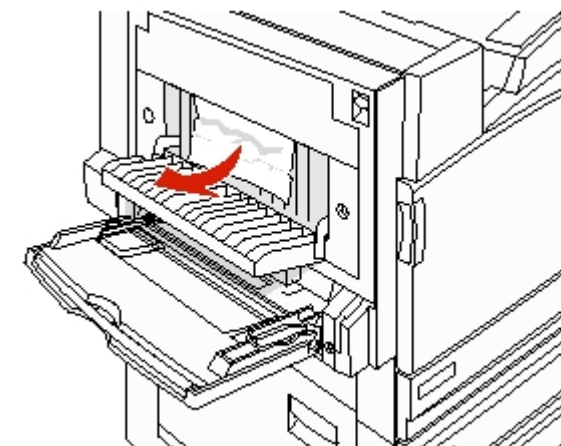

7 Close Door B.

8 Press .

241 paper jam

- 1 Open Door C.



- 2 Pull the paper down and toward you.

Note: Make sure all paper fragments are removed.

- 3 Close Door C.

- 4 Open Tray 1, and then remove any crumpled paper from the tray.

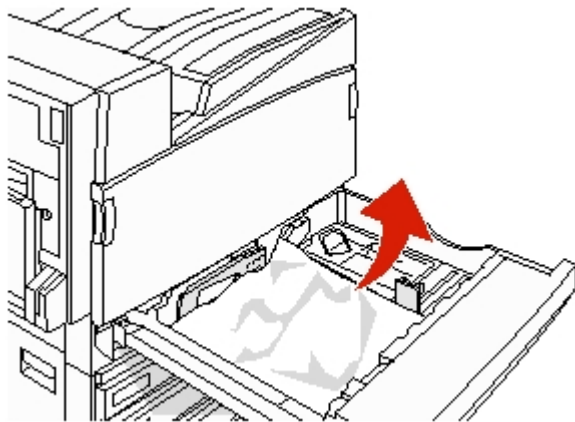

- 5 Close the tray.

- 6 Press .

242–244 paper jams

- 1 Open Door D.



- 2 Pull the paper down and away from the printer.



Note: Make sure all paper fragments are removed.

- 3 Close Door D.

- 4 Clear any crumpled paper from Trays 2–4.

- a Open Tray 2, and then remove any crumpled paper.

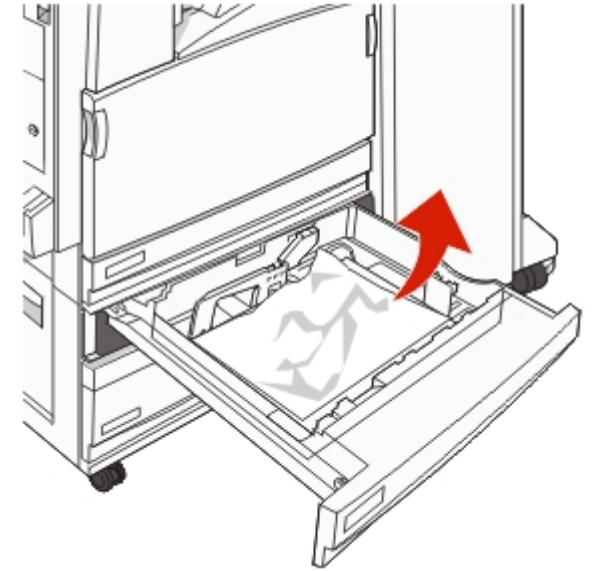

- b Close Tray 2.

- c Open Tray 3, and then remove any crumpled paper.

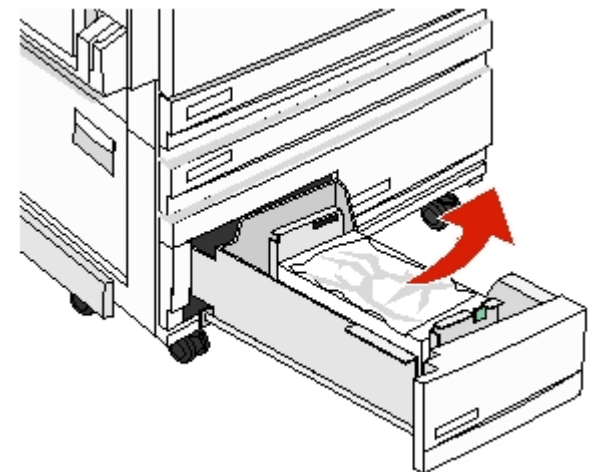

- d Close Tray 3.

e Open Tray 4, and then remove any crumpled paper.

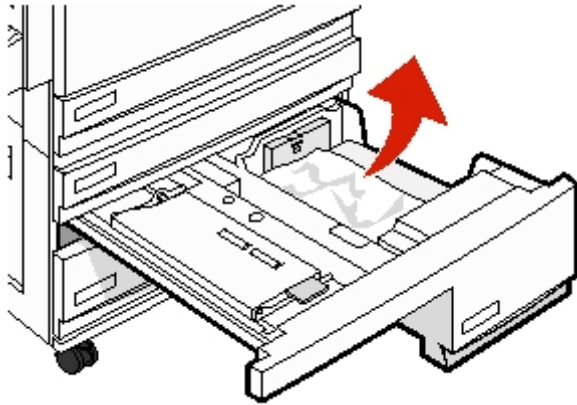

f Open the inside cover, and then remove any jammed paper.

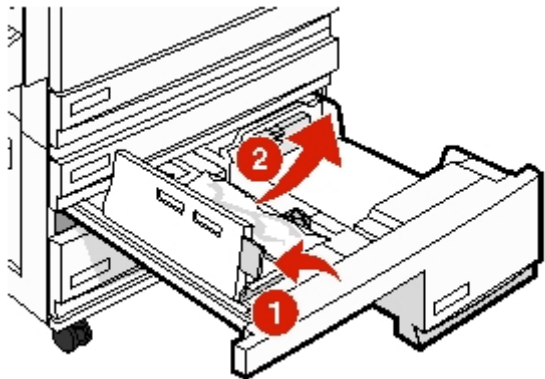

g Close the inside cover, and then close Tray 4.

5 Press .

250 paper jam

1 Remove the paper from the multipurpose feeder.

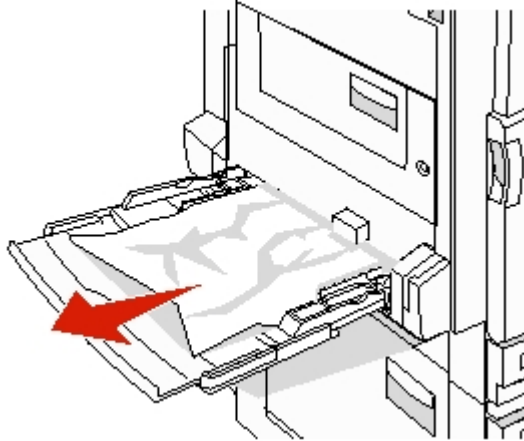

2 Flex the sheets of paper back and forth to loosen them, and then fan them. Do not fold or crease the paper. Straighten the edges on a level surface.

3 Load the paper into the multipurpose feeder.

4 Slide the paper guide toward the inside of the tray until it lightly rests against the edge of the paper.

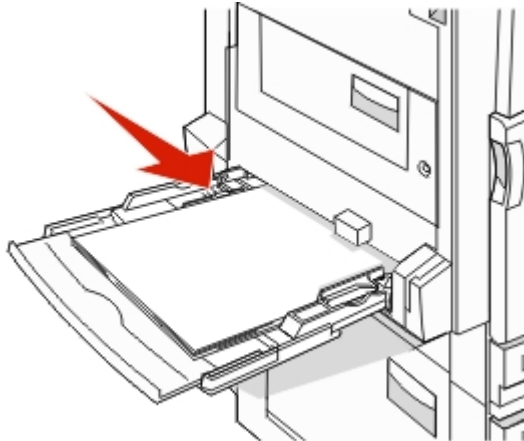

5 Press .

280–282 paper jams

1 Open Cover F.

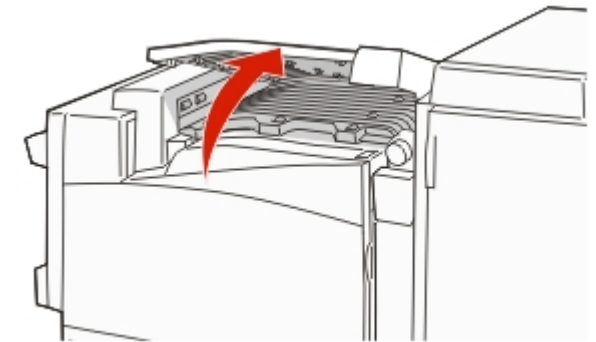

2 Remove the jammed paper.

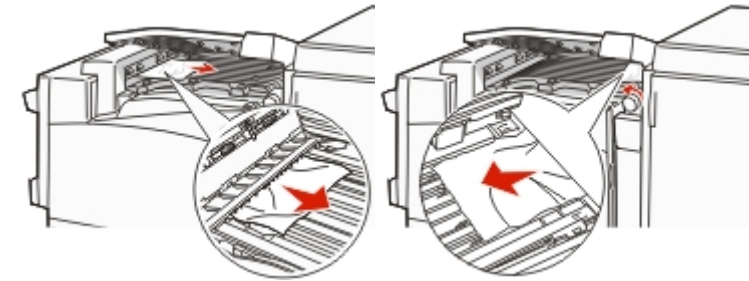

3 Close Cover F.

4 Press .

Note: If the paper jam on the right is difficult to remove, rotate the knob clockwise.

283–284 and 287–288 paper jams

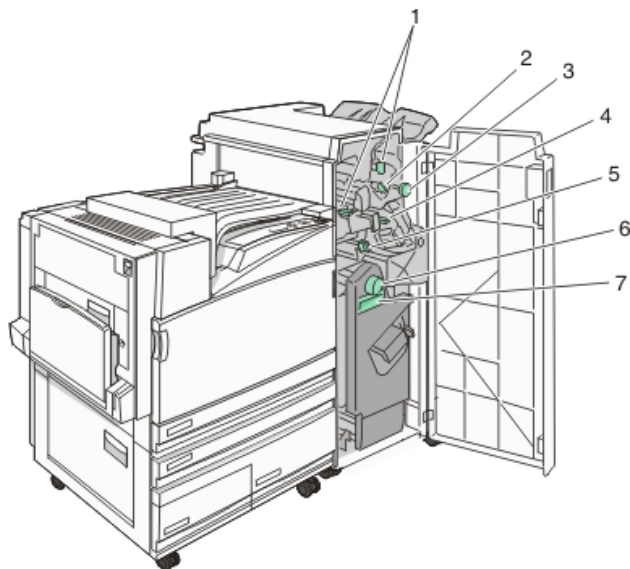

Covers, knobs, and handles located behind finisher Door G

	Cover, knob, or handle name
1	Cover G1
2	Cover G2
3	Knob G3
4	Cover G4
5	Cover G7
6	Knob G8
7	Handle G9

1 Open Door G.

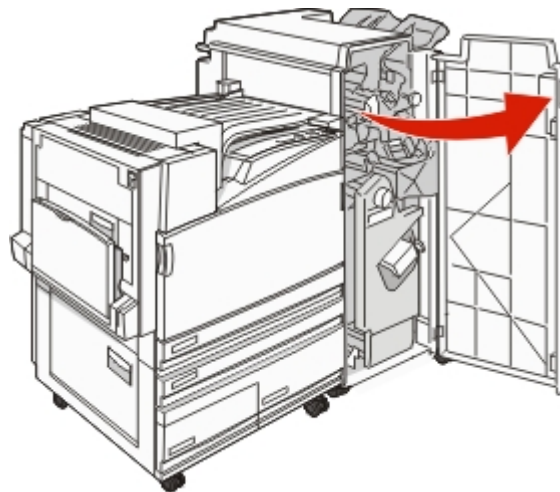

2 Lift both Cover G1 levers, and then remove any jammed paper.

3 Move Cover G2 to the right, and then remove any jammed paper.

Note: If the paper is jammed in the rollers, rotate Knob G3 counterclockwise.

4 Move Cover G4 down, and then remove any jammed paper.

5 Move Cover G7 to the left, and then remove any jammed paper.

6 Pull Handle G9 until the tray is completely open.

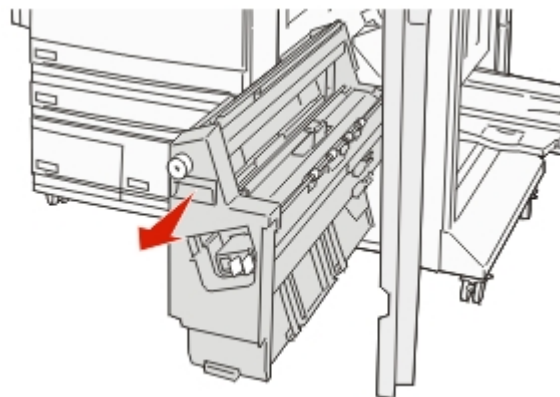

7 Lift the inside cover. If the paper is jammed in the rollers, rotate Knob G8 clockwise, and then remove the jammed paper.

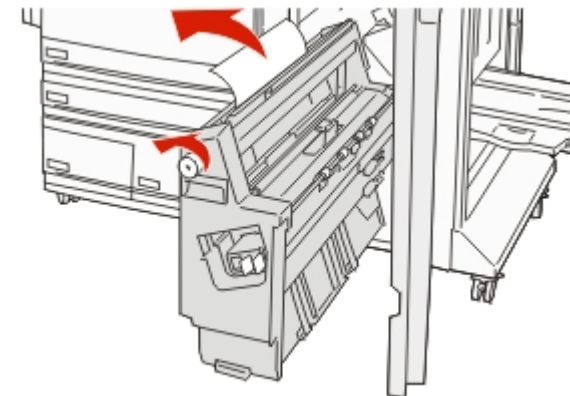

8 Close Door G.

9 Press .

284–286 paper jams

1 Open Door H.

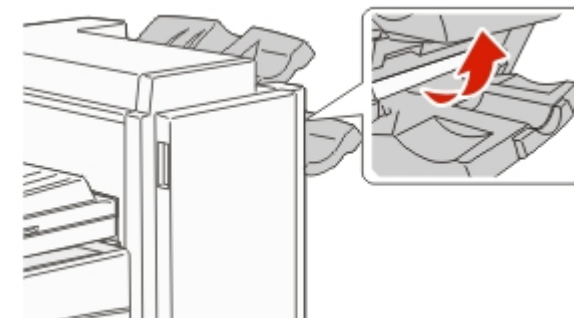

2 Remove the jammed paper.

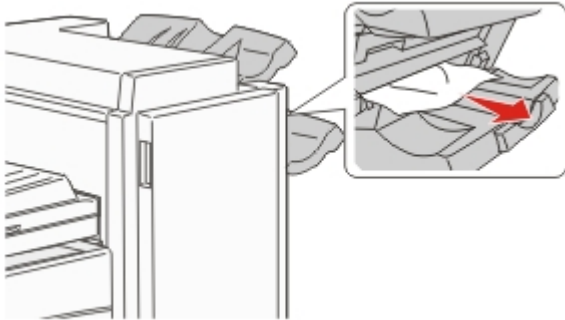

3 Close Door H.

4 Press .

289 staple jam

1 Open Door G.

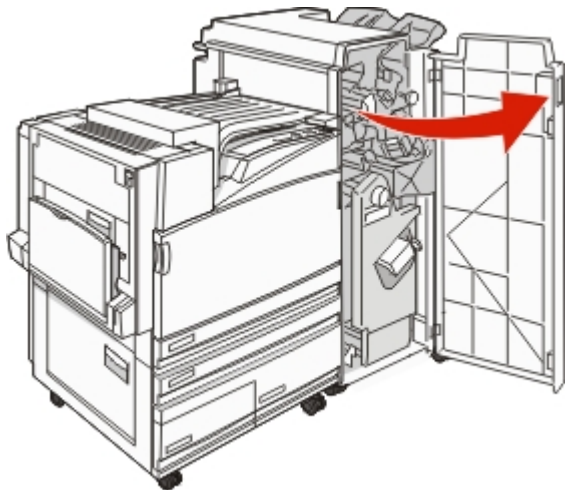

2 Slide the G5 stapler toward the front of the finisher.

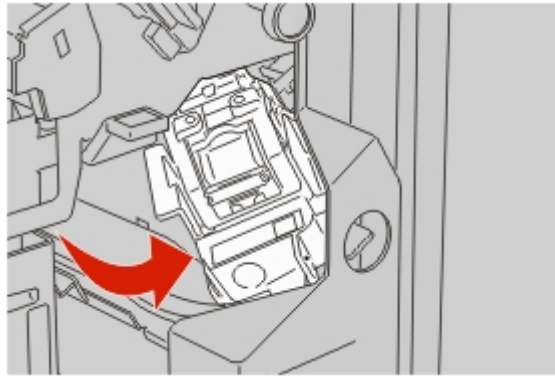

3 Lift the lever, and then remove the staple cartridge.

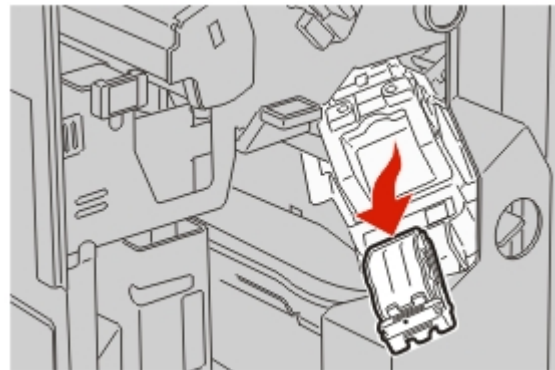

4 Open the staple cover.

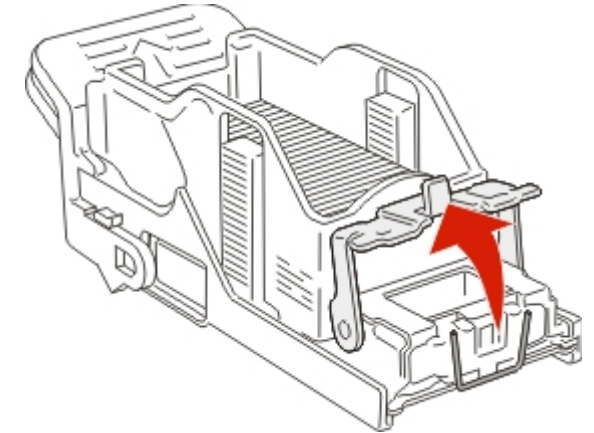

5 Remove the jammed staple, and then close the cover.

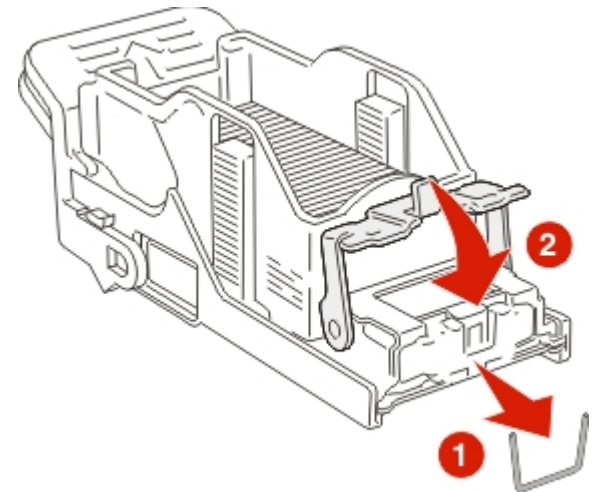

6 Place the staple cartridge into the upper stapler.

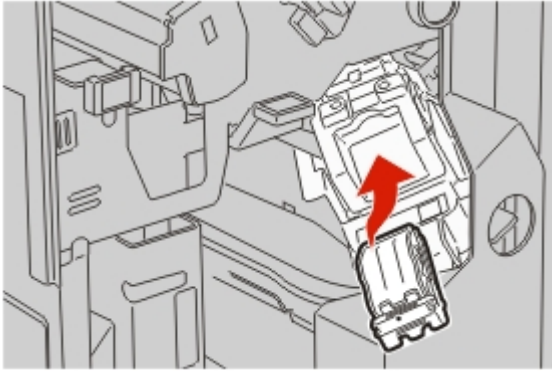

7 Open the lower staple drawer.

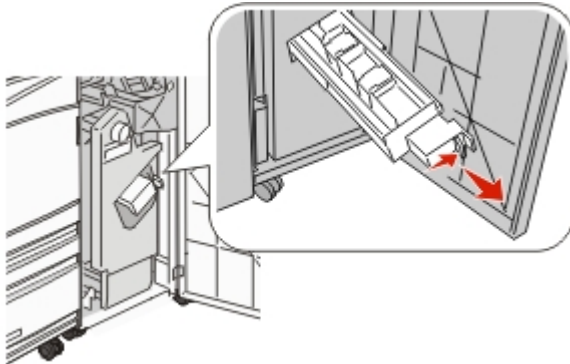

8 Remove the staple cartridge identified on the display.

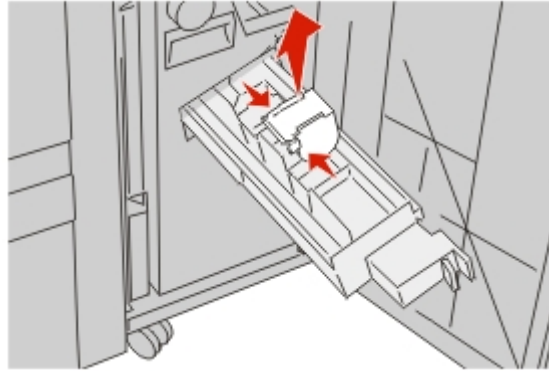

9 Remove the jammed staples, and then place the staple cartridge into the stapler.

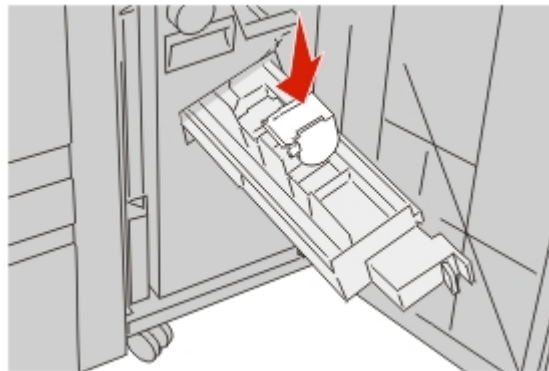

10 Close the staple drawer.

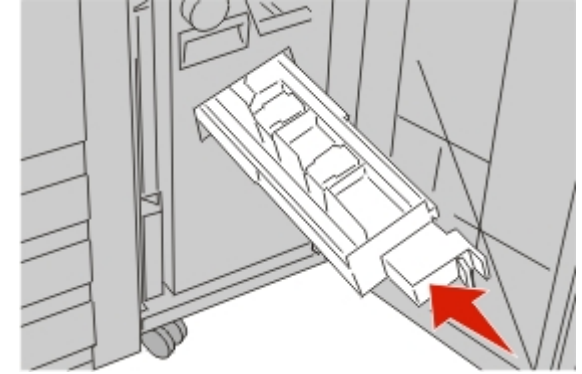

11 Close Door G.

12 Press .