



Lexmark X264dn, X363dn, X364dn, and X364dw

Maintenance Guide

Contents

Maintaining the printer.....	3
Cleaning the exterior of the printer.....	3
Cleaning the scanner glass.....	3
Cleaning the ADF separator rollers.....	4
Storing supplies.....	5
Checking the status of supplies from a network computer.....	5
Moving the printer to another location.....	6
Shipping the printer.....	6
Ordering supplies.....	7
Ordering toner cartridges.....	7
Ordering a photoconductor kit.....	7
Ordering ADF replacement parts.....	8
Replacing supplies.....	8
Replacing the toner cartridge.....	8
Replacing the photoconductor kit.....	10

Maintaining the printer

Cleaning the exterior of the printer

- 1 Make sure that the printer is turned off and unplugged from the wall outlet.



CAUTION—SHOCK HAZARD: To avoid the risk of electric shock when cleaning the exterior of the printer, unplug the power cord from the wall outlet and disconnect all cables to the printer before proceeding.

- 2 Remove all paper from the printer.
- 3 Dampen a clean, lint-free cloth with water.

Warning—Potential Damage: Do not use household cleaners or detergents, as they may damage the finish of the printer.

- 4 Wipe only the outside of the printer.

Warning—Potential Damage: Using a damp cloth to clean the interior may cause damage to your printer.

- 5 Make sure all areas of the printer are dry before beginning a new print job.

Cleaning the scanner glass

If you encounter print quality problems, such as streaks on copied or scanned images, clean the areas shown.

- 1 Slightly dampen a soft, lint-free cloth or paper towel with water.
- 2 Open the scanner cover.

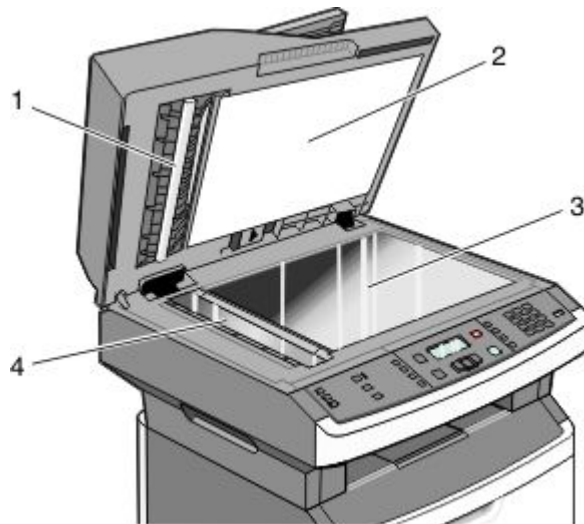

1	White underside of the ADF cover
2	White underside of the scanner cover
3	Scanner glass
4	ADF glass

- 3 Wipe the areas shown and let them dry.
- 4 Close the scanner cover.

Cleaning the ADF separator rollers

After you have copied over 50,000 copies using the ADF, clean the ADF separator rollers.

- 1 Open the ADF cover.

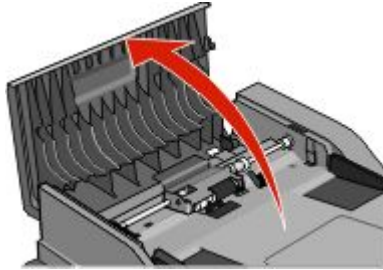

- 2 Unlock the separator roll.

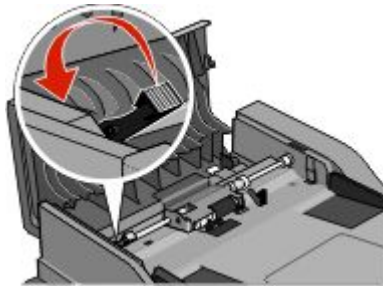

- 3 Remove the separator roll.

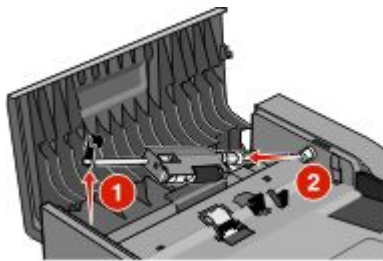

- 4 Use a clean, lint-free cloth dampened with water to wipe the separator rollers.

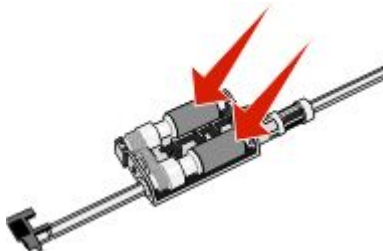

5 Reinstall the separator roll.

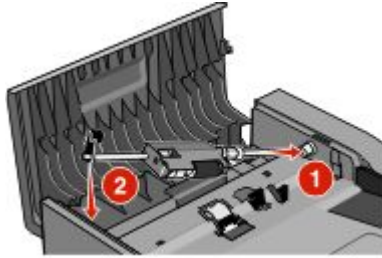

6 Lock the separator roll.

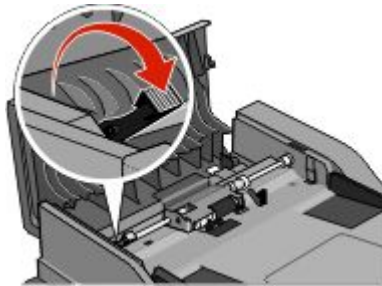

7 Close the ADF cover.

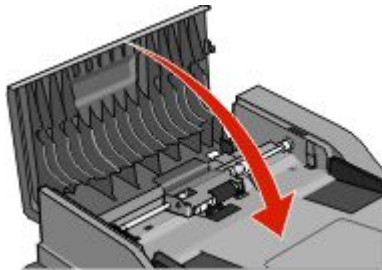

Storing supplies

Choose a cool, clean storage area for the printer supplies. Store supplies right side up in their original packing until you are ready to use them.

Do not expose supplies to:

- Direct sunlight
- Temperatures above 35°C (95°F)
- High humidity above 80%
- Salty air
- Corrosive gases
- Heavy dust

Checking the status of supplies from a network computer

Note: The computer must be connected to the same network as the printer.

1 Type the printer IP address into the address field of your Web browser.

Note: If you do not know the IP address of the printer, print a network setup page and locate the IP address in the TCP/IP section.

2 Click **Device Status**. The Device Status page appears, displaying a summary of supply levels.

Moving the printer to another location

Warning—Potential Damage: Damage to the printer caused by improper moving is not covered by the printer warranty.



CAUTION—POTENTIAL INJURY: Follow these guidelines to avoid personal injury or printer damage:

- Turn the printer off using the power switch, and then unplug the power cord from the wall outlet.
- Disconnect all cords and cables from the printer before moving it.
- Use the handholds located on both sides of the printer to lift it.
- Make sure your fingers are not under the printer when you set it down.
- Before setting up the printer, make sure there is adequate clearance around it. For more information, see the *User's Guide*.

The printer and options can be safely moved to another location by following these precautions:

- Any cart used to move the printer must be able to support its weight and have a large enough surface to support the full footprint of the printer.
- Keep the printer in an upright position.
- Avoid severe jarring movements.

Shipping the printer

When shipping the printer, use the original packaging or call the place of purchase for a relocation kit.

Ordering supplies

To order supplies in the U.S., contact Lexmark at 1-800-539-6275 for information about Lexmark authorized supplies dealers in your area. In other countries or regions, visit the Lexmark Web Site at www.lexmark.com or contact the place where you purchased the printer.

Warning—Potential Damage: Damage caused by the use of a supply or replacement item not produced by the manufacturer of this printer is not covered under warranty. Degraded print quality may result from using supplies or replacement items not produced by the manufacturer of this printer.

Note: All life estimates for printer supplies assume printing on letter- or A4-size plain paper.

Ordering toner cartridges

When **88 Cartridge Low** appears or when the print becomes faded:

- 1 Remove the toner cartridge.
- 2 Firmly shake the cartridge side-to-side and front-to-back several times to redistribute toner.

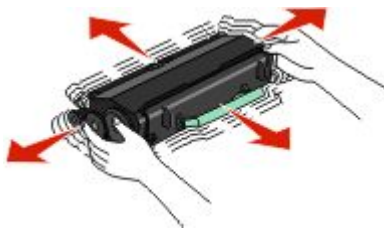

- 3 Reinsert the cartridge and continue printing.

Note: Repeat this procedure multiple times until the print remains faded, and then replace the cartridge.

Recommended toner cartridges and part numbers

Part Name	Regular Cartridge	Lexmark Return Program Cartridge
Toner Cartridge	X264A21G	X264A11G
High Yield Toner Cartridge	X264H21G	X264H11G

Ordering a photoconductor kit

The printer issues a message to let you know the photoconductor kit is near its end of life. At this time, order a photoconductor kit. You can also see the status of the photoconductor kit by printing a network setup page.

Part name	Part number
Photoconductor kit	E260X22G

Ordering ADF replacement parts

Order ADF replacement parts if you experience problems with paper double-feeding or failing to feed through the Automatic Document Feeder.

Part name	Part number
ADF input tray	40X5470
ADF separator pad	40X5472
ADF separator roll	40X5471

Replacing supplies

Replacing the toner cartridge

When **88 Cartridge is low** appears, or when you experience faded print, remove the toner cartridge. Firmly shake it side-to-side and front-to-back several times to redistribute the toner, and then reinsert it and continue printing. When shaking the cartridge no longer improves the print quality, replace the toner cartridge.

Note: You can check to see approximately how much toner is left in your cartridge by printing a menu settings page.

To replace the toner cartridge:

- 1 Open the front door by pressing the button on the left side of the printer and lowering the door.

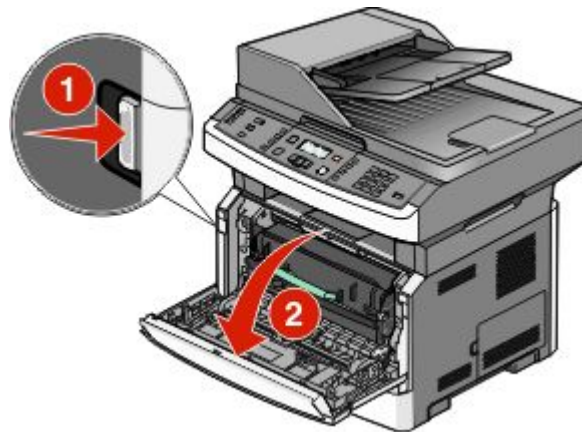

2 Press the button on the base of the photoconductor kit, and then pull the toner cartridge out using the handle.

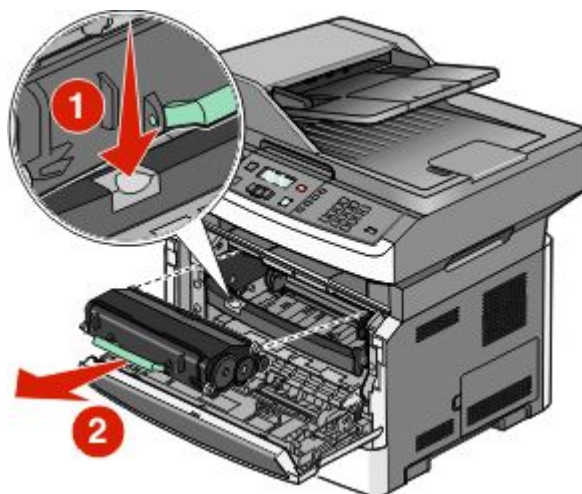

3 Unpack the new toner cartridge.

4 Shake the cartridge in all directions to distribute the toner.

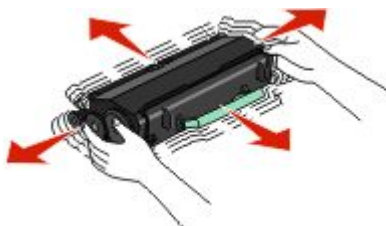

- 5 Install the new toner cartridge by aligning the rollers on the toner cartridge with the arrows on the tracks of the photoconductor kit. Push the toner cartridge in as far as it will go. The cartridge *clicks* into place when correctly installed.

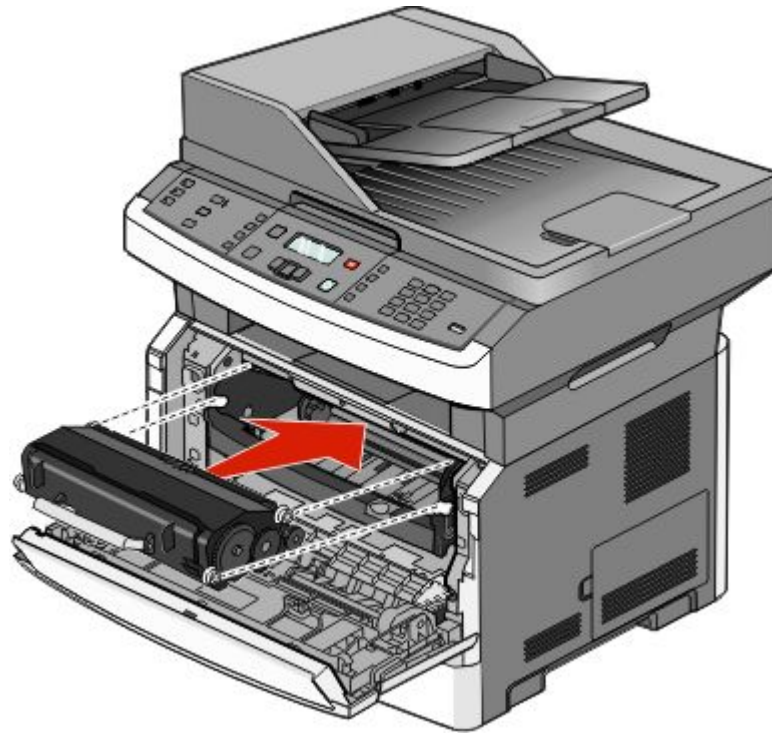

- 6 Close the front door.

Replacing the photoconductor kit

The printer automatically notifies you before the photoconductor kit reaches a page maximum by showing **84 PC Kit life warning** or **84 Replace PC Kit** on the display. You can also see the status of the photoconductor kit by printing a menu settings page.

When **84 PC Kit life warning** or **84 Replace PC Kit** first appears, you should immediately order a new photoconductor kit. While the printer may continue to function properly after the photoconductor kit has reached its official end-of-life, print quality significantly decreases.

Note: The photoconductor kit is one item only.

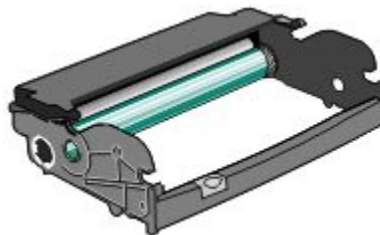

To replace the photoconductor kit:

- 1 Open the front door by pressing the button on the left side of the printer and lowering the front door.
- 2 Pull the photoconductor kit and toner cartridge out of the printer as a unit by pulling on the toner cartridge handle.

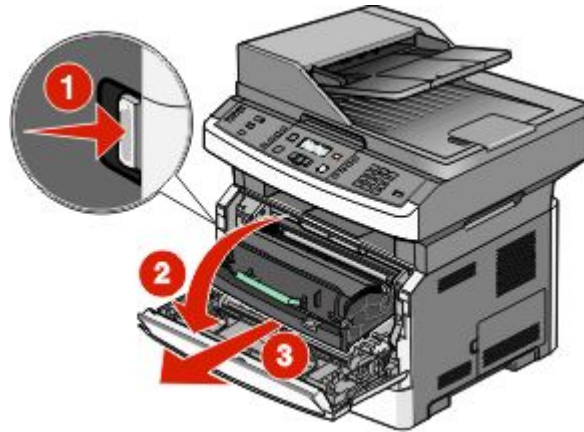

- 3 Place the unit on a flat, clean surface.



- 4 Press the button on the base of the photoconductor kit. Pull the toner cartridge up and out using the handle.

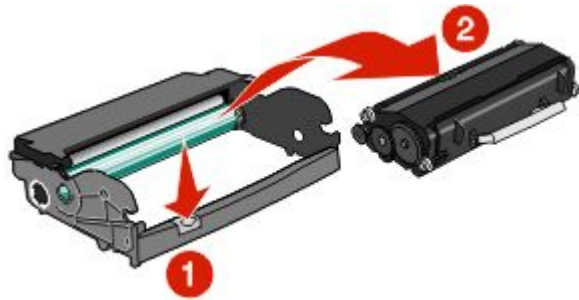

5 Unpack the new photoconductor kit. Be careful not to touch the photoconductor drum.



Warning—Potential Damage: When replacing a photoconductor kit, do not leave it exposed to direct light for an extended period of time. Extended light exposure can cause print quality problems.

6 Insert the toner cartridge into the photoconductor kit by aligning the rollers on the toner cartridge with the tracks. Push the toner cartridge until it *clicks* into place.

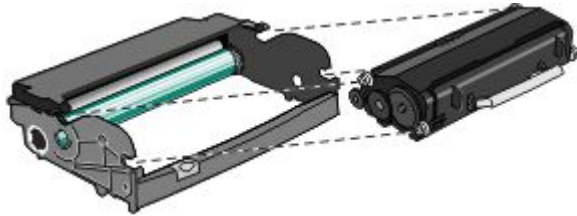

7 Install the unit into the printer by aligning the arrows on the guides of the unit with the arrows in the printer. Push the unit as far as it will go.

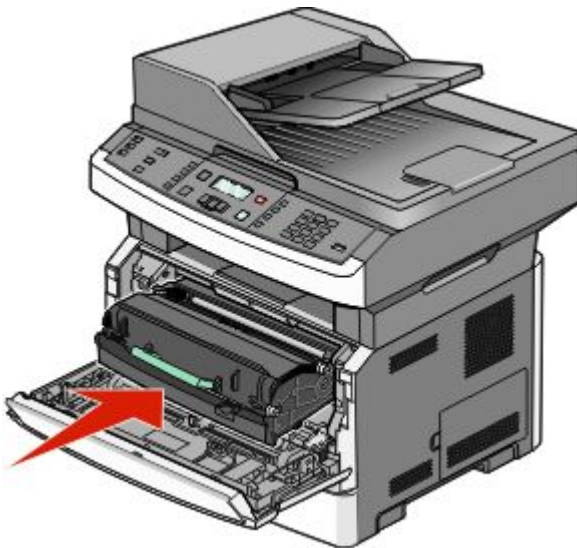

8 After you replace the photoconductor kit, reset the photoconductor counter. To reset the counter, see the instruction sheet that came with the new photoconductor kit.

Warning—Potential Damage: Resetting the photoconductor counter without replacing the photoconductor may damage your printer and void your warranty.

9 Close the front door.