

Printer overview

Basic printing

Printing ideas

Maintenance

Troubleshooting

Notices

Index

User's Guide for Linux

Use this User's Guide when you have questions about using your printer with Linux.

Navigating

- Click the categories in the left pane to navigate through the pages.
- Click the **blue text** to link to other parts of this User's Guide.
- Click the arrows at the bottom of the screen to move forward and backward through the pages.

Searching

- 1 From the Acrobat Edit menu, click Find.
- 2 In the Find What: box, type the word or phrase you want to search.
- 3 Click Find.

Printing

From the Acrobat File menu:

- 1 Click Page Setup, select the Landscape orientation button, and then click OK.
- 2 Click Print, specify the pages you want to print, and then click Print.



Printer overview

Basic printing

Printing ideas

Maintenance

Troubleshooting

Notices

Index

This section contains information about the printer hardware and software and how they work together.

- **Understanding the printer parts**
- **Understanding the printer software**



Printer overview

Basic printing

Printing ideas

Maintenance

Troubleshooting

Notices

Index

Understanding the printer parts

The table beginning on the next page describes each part.

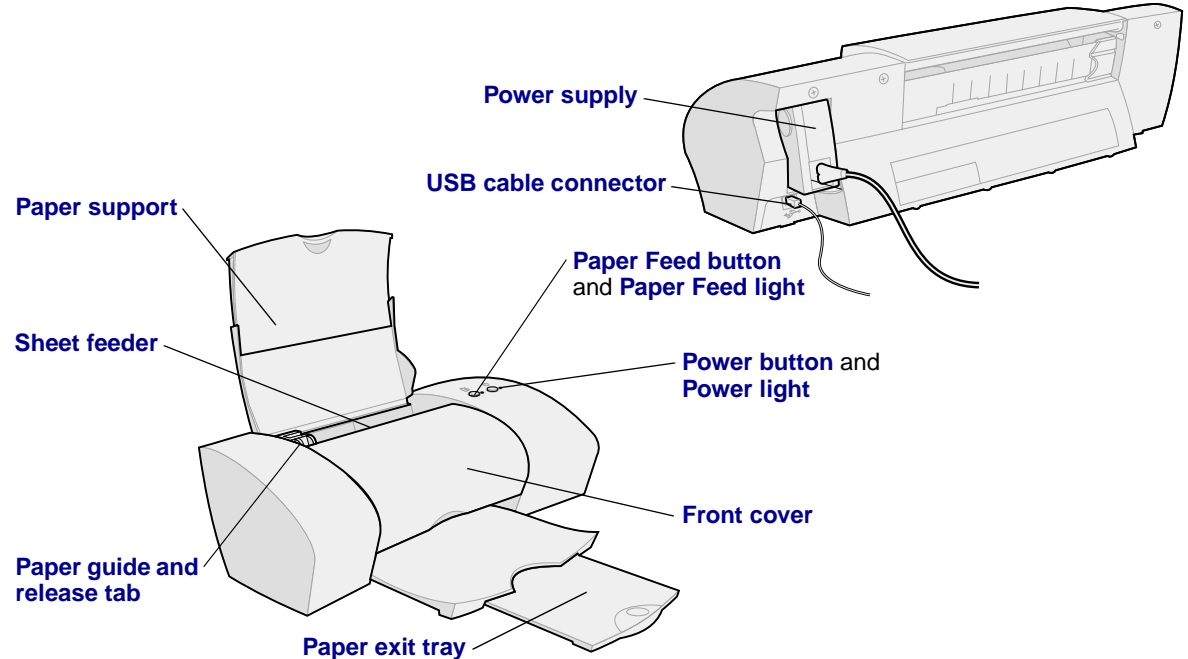

Printer overview

Basic printing

Printing ideas

Maintenance

Troubleshooting

Notices

Index

Use this:	When you want to:
Front cover	<ul style="list-style-type: none"> • Install or change print cartridges. • Clear paper jams.
Paper exit tray	Stack paper after printing.
Paper Feed button	<ul style="list-style-type: none"> • Eject paper from the printer. • Advance a sheet of paper into the sheet feeder.
Paper Feed light	Check the printer status. For more information, see Understanding error messages and flashing lights .
Paper guide and release tab	Adjust the paper guide against the left edge of the paper to make sure paper feeds correctly into the printer.
Paper support	Keep paper straight in the sheet feeder.
Power button	Turn the printer on or off.
Power light	Check the printer status. For more information, see Understanding error messages and flashing lights .
Power supply	Supply power to the printer.
Sheet feeder	Feed plain or specialty paper automatically. For information about the amount of paper you can load, see Printing ideas .
USB cable connector	Connect the printer to the computer with a USB cable.



Printer overview

Basic printing

Printing ideas

Maintenance

Troubleshooting

Notices

Index

Understanding the printer software

Your printer software works with your operating system to print documents with superior results. This software has two parts: the **Printer driver** and the **Lexmark Solution Center**.

Printer driver

The driver is where you change your printer settings. To print a typical document on plain paper, you do not need to change your printer settings. When you installed the printer software, the Page Setup dialog box and the Print dialog box were set to the default settings. The default settings are:

- Quality/Speed: Normal
- Type: Plain paper
- Paper Size: A4 or Letter
- Orientation: Portrait
- Style: Normal

For more information about the printer settings for printing on specialty papers, see **Printing ideas**.



Printer overview

Basic printing

Printing ideas

Maintenance

Troubleshooting

Notices

Index

Customizing the settings for your document

- 1 From the desktop, open your printer driver by typing `lexmarkz13` or `lexmarkz23-z33` at a command line. You can also select the file using the file manager.
- 2 From the Printer Settings tab, select the tab that contains the settings you want to change: **Quality/Copies tab**, **Paper Setup tab**, and **Print Style tab**.
- 3 Click OK to apply your settings.

Quality/Copies tab

From:	Select:
Quality/Speed	Quick Print, Normal, Better, or Best
Multiple Copies	<ul style="list-style-type: none">• Collate Copies, if you are printing more than one copy of a document, prints all the pages of the first copy, all the pages of the second copy, and so on• Print Last Page First to print your document in reverse order• The number of Copies you want to print
(Lexmark Z23 and Lexmark Z33 only)	Print Color Images in Black and White to save the ink in your color cartridge.



Printer overview

Basic printing

Printing ideas

Maintenance

Troubleshooting

Notices

Index

Paper Setup tab

From:	Select:
Type	Plain Paper, Envelope, Banner, Coated Paper, Photo/Glossy Paper, Transparency, Iron-On Transfer, or Greeting Card
Paper Size	A size specific to your paper type. If your Paper Size is not listed, choose Custom Size. For help, see Printing on custom size paper .
Orientation	Portrait or Landscape

Print Style tab

From:	Select:
Style	Normal, Banner, or Mirror

Changing the page settings from a software application

To change paper size and orientation for your current document from a software application:

- 1 From the File menu, choose Page Setup.
The Page Setup dialog box opens.
- 2 Change the settings as needed.
- 3 Click OK to apply your settings and exit Page Setup.



Printer overview

Basic printing

Printing ideas

Maintenance

Troubleshooting

Notices

Index

Lexmark Solution Center

From the Lexmark Solution Center you can print a test page, maintain your cartridges, and view the printer software Help.

Accessing the Lexmark Solution Center

- 1 From the desktop, type `z13lsc` or `z23-z33lsc` at a command line. You can also select the file using the file manager.

You can choose between **Printing ideas**, **Troubleshooting**, **Ink Cartridges**, **Contact Information**, and **Advanced**.

- 2 Click Exit when you are finished.



Printer overview

Basic printing

Printing ideas

Maintenance

Troubleshooting

Notices

Index

Lexmark Solution Center

This section:	Contains information about:
Printing ideas	Printing on specialty papers such as photo paper and transparencies
Troubleshooting	Solving printer problems
Ink Cartridges	<ul style="list-style-type: none">• Print Cartridge Installation For help, see Installing the cartridge.• Ordering Ink or Supplies For help, see Ordering supplies.• Clean the Cartridge Nozzles For help, see Clean the print cartridge nozzles.• Align the Cartridges For help, see Aligning the print cartridges.• Print a Test Page For help, see Printing a test page.• Clean Paper Feed Rollers• Troubleshooting
Contact Information	Ordering ink and supplies
Advanced	Advanced features of your printer



Printer overview

Basic printing

Printing ideas

Maintenance

Troubleshooting

Notices

Index

Basic printing is easy:

Step 1: Load the paper

Step 2: Customize the print settings

Step 3: Print your document

Note: For help printing on specialty paper (such as photo paper, banner paper, transparencies, or iron-on transfers), see **Printing ideas**.



Printer overview

Basic printing

Printing ideas

Maintenance

Troubleshooting

Notices

Index

Step 1: Load the paper

You can load up to 100 sheets of plain paper at a time, depending on the thickness of the paper.

- 1 Place the paper against the right side of the paper support with the print side facing you.

Note: The top of your A4 size paper should extend above the top of the paper support. (Letter size paper should align with the top of the paper support.)

- 2 Squeeze the release tab and the paper guide together. Slide the paper guide to the left edge of the paper.

For information about loading specialty paper, see **Printing ideas**.

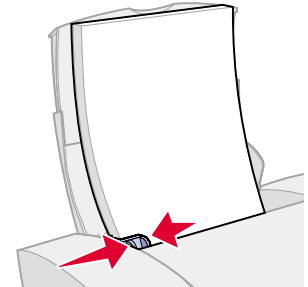

Printer overview

Basic printing

Printing ideas

Maintenance

Troubleshooting

Notices

Index

Step 2: Customize the print settings

If you are using plain, A4 or letter size paper, and you want normal print quality and speed, you don't need to adjust the print settings.

If you are using specialty paper, such as photo paper, card stock, envelopes, or banner paper, see [Printing ideas](#) to customize your print settings.

For more information about the different print settings, see [Understanding the printer software](#).



Printer overview

Basic printing

Printing ideas

Maintenance

Troubleshooting

Notices

Index

Step 3: Print your document

After you load the paper and customize the print settings, you are ready to print.

Printing from a software application

- 1 From the File menu, choose Print.

The Print dialog box opens.

- 2 Select your printer from the list of installed printers.

If the software application does not offer a list of printers, but provides a place to enter your printer name, type:

```
lpr -Pprintername
```

where *printername* = `lexmarkz13` or `lexmarkz23-z33`.

- 3 Click Enter.



Printer overview

Basic printing

Printing ideas

Maintenance

Troubleshooting

Notices

Index

Printing from an xterm window

1 Open an xterm window.

2 Type:

```
lpr -Pprintername filename
```

where *printername* = `lexmarkz13` or `lexmarkz23-z33` and *filename* = the name of your file.

3 Click Enter.



Printer overview

Basic printing

Printing ideas

Maintenance

Troubleshooting

Notices

Index

Your printer does more than just print typical text documents. This section shows you how to get the most from your printer, taking you step by step through the printing process for specialty paper types.

- **Printing photos**
- **Printing on premium paper**
- **Printing cards**
- **Printing envelopes**
- **Printing color images in black and white**
- **Printing labels**
- **Printing on custom size paper**
- **Printing iron-on transfers**
- **Printing transparencies**
- **Printing your document in reverse order**
- **Printing a banner**



Printer overview

Basic printing

Printing ideas

Maintenance

Troubleshooting

Notices

Index

Printing photos

You can print up to 25 sheets of coated, photo, or glossy paper at a time, depending on the thickness of the paper. You may want to print on plain paper before loading your photo paper and changing your settings. To print on photo cards, see [Printing cards](#).

Step 1: Load the photo paper

- If your paper came with instructions, read them carefully.
- Make sure the glossy or coated side is facing you.
- Load the photo paper vertically against the right side of the paper support.
- Don't push the paper too far down into the sheet feeder.
- Slide the paper guide to the left side of the photo paper.

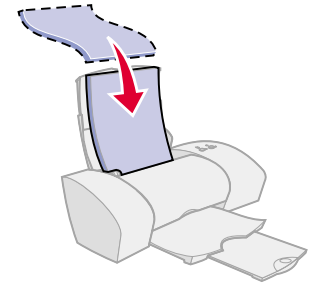

Printer overview

Basic printing

Printing ideas

Maintenance

Troubleshooting

Notices

Index

Step 2: Customize the print settings

For help, see [Understanding the printer software](#).

- 1 Select a print quality:
 - a From Printer Settings, choose the Quality/Copies tab.
 - b From the Quality/Speed area, select Better or Best.

Note: Higher print quality settings result in better quality documents, but may take longer to print.

- 2 Select a paper type:
 - a From Printer Settings, choose the Paper Setup tab.
 - b From the Type area, select Photo/Glossy Paper or Coated Paper.
- 3 Choose a paper size:
 - a From Printer Settings, choose the Paper Setup tab.
 - b From the Paper Size menu, choose the correct size. For more information about printing on custom size paper, see [Printing on custom size paper](#).
- 4 Click OK to apply your settings.



Printer overview

Basic printing

Printing ideas

Maintenance

Troubleshooting

Notices

Index

Step 3: Print your photos

For help, see [Print your document](#).

Note: To prevent smudging, remove each photo as it exits the printer and let it dry before stacking.



Printer overview

Basic printing

Printing ideas

Maintenance

Troubleshooting

Notices

Index

Printing on premium paper

You can print up to 100 pages of premium paper at a time, depending on the thickness of the paper.

Step 1: Load the premium paper

- If your paper came with instructions, read them carefully.
- If there is a special mark on the paper, make sure the mark is facing away from you.
- Load the paper vertically against the right side of the paper support.
- Don't push the paper too far down into the sheet feeder.
- Slide the paper guide to the left side of the paper.

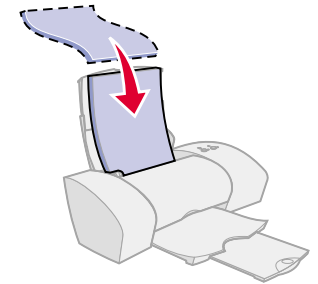

Printer overview

Basic printing

Printing ideas

Maintenance

Troubleshooting

Notices

Index

Step 2: Customize the print settings

For help, see [Understanding the printer software](#).

- 1 Select a print quality:
 - a From Printer Settings, choose the Quality/Copies tab.
 - b From the Quality/Speed area, select Better or Best.

Note: Higher print quality settings result in better quality documents, but may take longer to print.

- 2 Select a paper type:
 - a From Printer Settings, choose the Paper Setup tab.
 - b From the Type area, select Plain Paper.
- 3 Choose a paper size:
 - a From Printer Settings, choose the Paper Setup tab.
 - b From the Paper Size menu, choose the correct size. For more information about printing on custom size paper, see [Printing on custom size paper](#).
- 4 Click OK to apply your settings.



Printer overview

Basic printing

Printing ideas

Maintenance

Troubleshooting

Notices

Index

Step 3: Print your document

For help, see [Print your document](#).



Printer overview

Basic printing

Printing ideas

Maintenance

Troubleshooting

Notices

Index

Printing cards

You can print up to 10 greeting cards, index cards, photo cards, or postcards at a time, depending on the thickness of the cards.

Step 1: Load the cards

- If your cards came with instructions, read them carefully.
- Make sure the print side is facing you.
- Load the cards vertically against the right side of the paper support.
- Don't push the cards too far down into the sheet feeder.
- Slide the paper guide to the left side of the cards.

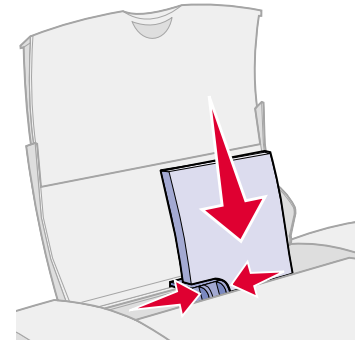

Step 2: Customize the print settings

For help, see [Understanding the printer software](#).

- 1 Select a print quality:
 - a From Printer Settings, choose the Quality/Copies tab.
 - b From the Quality/Speed area, select Normal or Better.



Printer overview

Basic printing

Printing ideas

Maintenance

Troubleshooting

Notices

Index

2 Select a paper type:

- a From Printer Settings, choose the Paper Setup tab.
- b From the Type area, select Greeting Card.

3 Choose a paper size:

- a From Printer Settings, choose the Paper Setup tab.
- b From the Paper Size menu, choose the correct size. For more information about printing on custom size paper, see **Printing on custom size paper**.

4 Click OK to apply your settings.

Step 3: Print your cards

For help, see **Print your document**.



Printer overview

Basic printing

Printing ideas

Maintenance

Troubleshooting

Notices

Index

Printing envelopes

You can print up to 10 envelopes at a time, depending on the thickness of the envelopes.

Step 1: Load the envelopes

Note: Do not use envelopes with holes, windows, deep embossing, metal clasps, string ties, or folding bars.

- Make sure the print side is facing you.
- Make sure the stamp is located in the upper left corner.
- Load the envelopes vertically against the right side of the paper support.
- Don't push the envelopes too far down into the sheet feeder.
- Slide the paper guide to the left side of the envelopes.

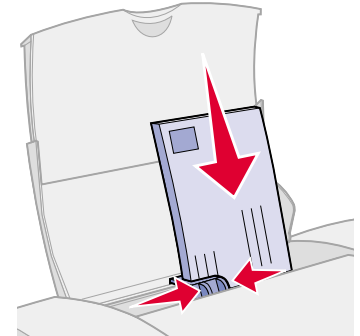

Printer overview

Basic printing

Printing ideas

Maintenance

Troubleshooting

Notices

Index

Step 2: Customize the print settings

For help, see [Understanding the printer software](#).

- 1 Select a paper type:
 - a From Printer Settings, choose the Paper Setup tab.
 - b From the Type area, select Envelope.
- 2 Choose an envelope size:
 - a From Printer Settings, choose the Paper Setup tab.
 - b From the Envelope Size menu choose the correct size. For more information about printing on custom size paper, see [Printing on custom size paper](#).
- 3 Select the orientation:
 - a From Printer Settings, choose the Paper Setup tab.
 - b From the Orientation area, select Landscape.
- 4 Click OK to apply your settings.

Note: Many software applications are designed to override the settings in Paper Setup. Make sure Landscape orientation is also selected in your software application.



Printer overview

Basic printing

Printing ideas

Maintenance

Troubleshooting

Notices

Index

Step 3: Print your envelopes

For help, see [Print your document](#).



Printer overview

Basic printing

Printing ideas

Maintenance

Troubleshooting

Notices

Index

Printing color images in black and white

You can print up to 100 sheets of paper at a time, depending on the thickness of the paper. Printing in black only helps to conserve ink in your color print cartridge.

Step 1: Load the paper

- Make sure the print side is facing you.
- Load the paper vertically against the right side of the paper support.
- Don't push the paper too far down into the sheet feeder.
- Slide the paper guide to the left side of the paper.

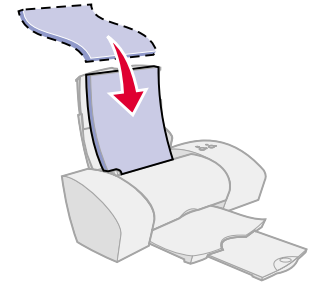

Printer overview

Basic printing

Printing ideas

Maintenance

Troubleshooting

Notices

Index

Step 2: Customize the print settings

For help, see [Understanding the printer software](#).

- 1 To print color images in black and white:
 - a From Printer Settings, choose the Quality/Copies tab.
 - b Select Print Color Images in Black and White.

Note: This option is only available in the Lexmark Z23 and the Lexmark Z33 printer driver. Lexmark Z13 users print with black cartridge installed.

- c Click OK.
- 2 Further customize your document following the steps in [Basic printing](#) or [Printing ideas](#).

Step 3: Print your document

For help, see [Print your document](#).



Printer overview

Basic printing

Printing ideas

Maintenance

Troubleshooting

Notices

Index

Printing labels

You can print up to 25 sheets of labels at a time, depending on the thickness of the sheets.

Step 1: Load the labels

- Use labels designed for inkjet printers.
- If your labels came with instructions, read them carefully.
- Do not print within 1 mm (0.04 in.) of the edge of a label.
- Make sure there are no missing or curled labels.
- Make sure the print side is facing you.
- Load the labels vertically against the right side of the paper support.
- Don't push the labels too far down into the sheet feeder.
- Slide the paper guide to the left side of the labels.

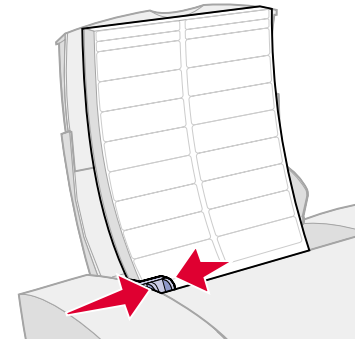

Printer overview

Basic printing

Printing ideas

Maintenance

Troubleshooting

Notices

Index

Step 2: Customize the print settings

For help, see [Understanding the printer software](#).

- 1 Select a print quality:
 - a From Printer Settings, choose the Quality/Copies tab.
 - b From the Quality/Speed area, select Normal.
- 2 Select a paper type:
 - a From Printer Settings, choose the Paper Setup tab.
 - b From the Type area, select Plain Paper.
- 3 Choose a paper size:
 - a From Printer Settings, choose the Paper Setup tab.
 - b From the Paper Size menu, choose A4 or Letter.
- 4 Click OK to apply your settings.

Step 3: Print your labels

For help, see [Print your document](#).



Printer overview

Basic printing

Printing ideas

Maintenance

Troubleshooting

Notices

Index

Printing on custom size paper

You can print up to 100 sheets of custom size paper at a time, depending on the thickness of the paper.

Step 1: Load the custom size paper

- Make sure your paper size fit within these dimensions:
 - Width: 76 to 216 mm (3 to 8.5 in.)
 - Length: 127 to 432 mm (5 to 17 in.)
- Make sure the print side is facing you.
- Load the paper vertically against the right side of the paper support.
- Don't push the paper too far down into the sheet feeder.
- Slide the paper guide to the left side of the paper.

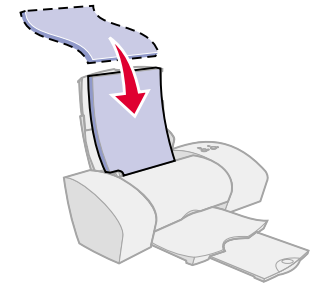

Printer overview

Basic printing

Printing ideas

Maintenance

Troubleshooting

Notices

Index

Step 2: Customize the print settings

For help, see [Understanding the printer software](#).

- 1 Create a custom paper size:
 - a From the Printer Settings, choose the Paper Setup tab.
 - b From the Paper Size menu, choose Custom Size.
A dialog box displays on the screen.
 - c From the Units area, select Millimeters or Inches.
 - d Type the dimensions for your custom paper size.
 - e Click OK.
- 2 Further customize your document following the steps in [Basic printing](#) or [Printing ideas](#).

Step 3: Print your document

For help, see [Print your document](#).



Printer overview

Basic printing

Printing ideas

Maintenance

Troubleshooting

Notices

Index

Printing iron-on transfers

You can print up to 25 iron-on transfers at a time, depending on the thickness of the transfer. You may want to print on plain paper before loading your iron-on transfers.

Step 1: Load the iron-on transfers

- If your paper came with instructions, read them carefully.
- Make sure the print side (blank side) is facing you.
- Load the iron-on transfers vertically against the right side of the paper support.
- Don't push the iron-on transfers too far down into the sheet feeder.
- Slide the paper guide to the left side of the iron-on transfers.

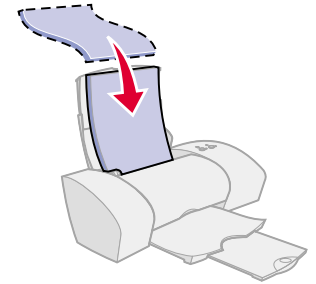

Printer overview

Basic printing

Printing ideas

Maintenance

Troubleshooting

Notices

Index

Step 2: Customize the print settings

For help, see [Understanding the printer software](#).

- 1 Select a paper type:
 - a From Printer Settings, choose the Paper Setup tab.
 - b From the Type area, select Iron-on Transfer.
- 2 If your software application does not have mirror or iron-on settings, select a print style:
 - a From Printer Settings, choose the Print Style tab.
 - b From the Style area, select Mirror.
- 3 Click OK to apply your settings.

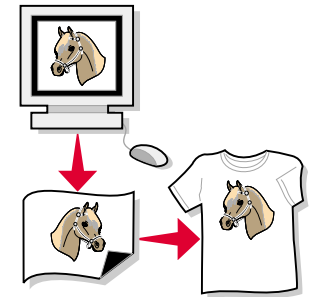

Step 3: Print your iron-on transfer

For help, see [Print your document](#).

Note: To prevent smudging, remove each iron-on transfer as it exits the printer and let it to dry before stacking.



Printer overview

Basic printing

Printing ideas

Maintenance

Troubleshooting

Notices

Index

Printing transparencies

You can print up to 25 transparencies at a time, depending on the thickness of the transparencies.

Step 1: Load the transparencies

- Use transparencies designed for inkjet printers.
- If your transparencies came with instructions, read them carefully.
- Make sure the rough side (print side) of the transparencies is facing you. If the transparencies have a removable stripe, make sure each stripe is facing away from you and down.
- Load the transparencies vertically against the right side of the paper support.
- Don't push the transparencies too far down into the sheet feeder.
- Slide the paper guide to the left side of the transparencies.

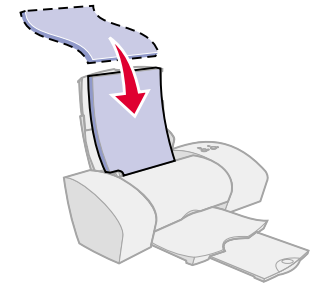

Printer overview

Basic printing

Printing ideas

Maintenance

Troubleshooting

Notices

Index

Step 2: Customize the print settings

For help, see [Understanding the printer software](#).

- 1 Select a print quality:
 - a From Printer Settings, choose the Quality/Copies tab.
 - b From the Quality/Speed area, select Normal or Better.

Note: Higher print quality settings result in better print quality, but require more drying time.

- 2 Select a paper type:
 - a From Printer Settings, choose the Paper Setup tab.
 - b From the Type area, select Transparency.
- 3 Choose a paper size:
 - a From Printer Settings, choose the Paper Setup tab.
 - b From the Paper Size menu, choose A4 or Letter.
- 4 Click OK to apply your settings.



Printer overview

Basic printing

Printing ideas

Maintenance

Troubleshooting

Notices

Index

Step 3: Print your transparencies

For help, see [Print your document](#).

Note: To prevent smudging, remove each transparency as it exits the printer and let it dry before stacking.



Printer overview

Basic printing

Printing ideas

Maintenance

Troubleshooting

Notices

Index

Printing your document in reverse order

You can print up to 100 sheets of paper at a time, depending on the thickness of the paper.

Step 1: Load the paper

- Make sure the print side is facing you.
- Load the paper vertically against the right side of the paper support.
- Don't push the paper too far down into the sheet feeder.
- Slide the paper guide to the left side of the paper.

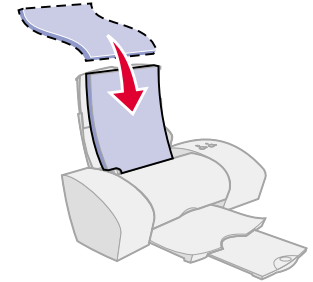

Printer overview

Basic printing

Printing ideas

Maintenance

Troubleshooting

Notices

Index

Step 2: Customize the print settings

For help, see [Understanding the printer software](#).

- 1 To print the last page first:
 - a From Printer Settings, choose the Quality/Copies tab.
 - b Select Print Last Page First.
 - c Click OK.
- 2 Further customize your document following the steps in [Basic printing](#) or [Printing ideas](#).

Step 3: Print your document

For help, see [Print your document](#).



Printer overview

Basic printing

Printing ideas

Maintenance

Troubleshooting

Notices

Index

Printing a banner

You can print up to 20 sheets of banner paper at a time.

Step 1: Load the banner paper

- 1 Remove any paper from the sheet feeder.
- 2 Lower the top portion of the paper support halfway.
- 3 Place a stack of banner paper with *only* the number of sheets you need to print your banner behind the printer.

Note: Loading excess banner paper may cause a paper jam. For help, see **The printer has a paper jam.**

- 4 Load the leading edge of the first page into the sheet feeder with the right side against the paper support.
- 5 Slide the paper guide to the left edge of the paper.

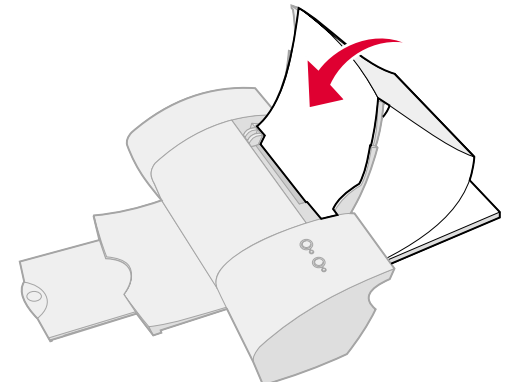
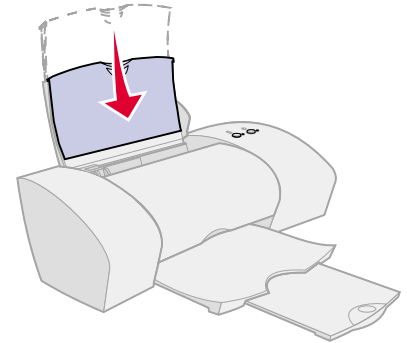

Printer overview

Basic printing

Printing ideas

Maintenance

Troubleshooting

Notices

Index

Step 2: Customize the print settings

For help, see [Understanding the printer software](#).

- 1 Select a paper type:
 - a From Printer Settings, choose the Paper Setup tab.
 - b From the Type area, select Banner.

Note: If you do not select Banner as the Type, your banner paper will cause a paper jam. For help, see [The printer has a paper jam](#).

- 2 Choose a banner size:
 - a From Printer Settings, choose the Paper Setup tab.
 - b From the Banner Size menu, choose A4 or Letter.
- 3 Select the orientation:
 - a From Printer Settings, choose the Paper Setup tab.
 - b From the Orientation area, select Portrait or Landscape.



Printer overview

Basic printing

Printing ideas

Maintenance

Troubleshooting

Notices

Index

- 4 Select the Style:
 - a From Printer Settings, choose the Print Style tab.
 - b From the Style area, select Banner.
- 5 Click OK to apply your settings.

Step 3: Print your banner

For help, see [Print your document](#).

Note: Extend the paper support all the way up for your next printing job.



Printer overview

Basic printing

Printing ideas

Maintenance

Troubleshooting

Notices

Index

This section contains information to help you maintain your printer and its parts.

- **Replacing a print cartridge**
- **Aligning the print cartridges**
- **Preserving the print cartridges**
- **Storing an extra print cartridge**
- **Ordering supplies**



Printer overview

Basic printing

Printing ideas

Maintenance

Troubleshooting

Notices

Index

Replacing a print cartridge

Before you install a new or replacement print cartridge, remove the used one.

Removing the used cartridge

- 1 Make sure the Power light is on.
- 2 Raise the front cover.

The print cartridge carrier moves to the loading position, unless the printer is busy.

- 3 Remove the used print cartridge and store it in an airtight container or dispose of it properly. If you own a Lexmark Z13 printer, you can store the cartridge in the print cartridge storage unit, see [Storing an extra print cartridge](#).

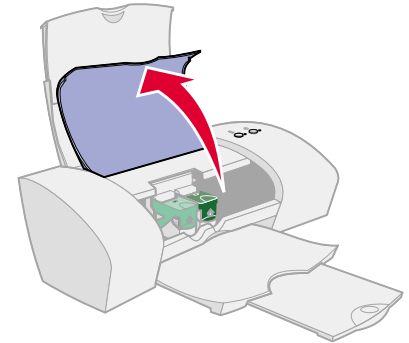

Printer overview

Basic printing

Printing ideas

Maintenance

Troubleshooting

Notices

Index

Installing the cartridge

For best results, use Lexmark supplies. Refilling cartridges can affect print quality and cause damage to the printer. Use part number 10N0016 to order a black cartridge, and part number 10N0026 to order a color cartridge.

- 1 If you are installing a new cartridge, remove the sticker and transparent tape from the back and bottom of the print cartridge.

Warning: Do **not** touch the gold contact areas on back and bottom of the print cartridge.

- 2 Click your printer name for instructions on installing the print cartridges:

[Lexmark Z13](#)

[Lexmark Z23](#)

[Lexmark Z33](#)

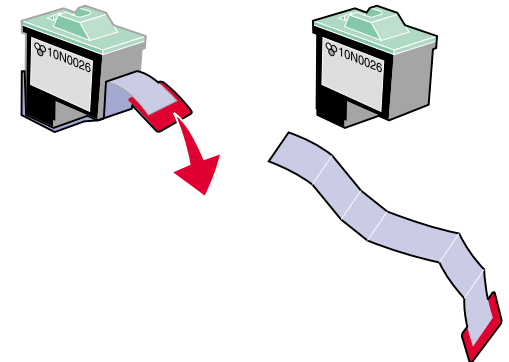

Printer overview

Basic printing

Printing ideas

Maintenance

Troubleshooting

Notices

Index

Lexmark Z13

Your printer shipped with a color print cartridge (P/N 10N0026). You may also purchase a black cartridge (P/N 10N0016) separately. For more information, see **Ordering supplies**.

Your printer uses one print cartridge at a time: either a black or a color cartridge.

To install a print cartridge:

a Open the cartridge carrier lid.

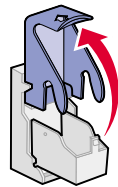

b Insert the print cartridge into the carrier.

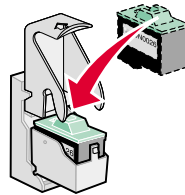

c Close the carrier lid completely.

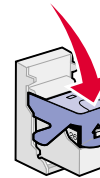

d Close the front cover. Continue with **Selecting the cartridge in the software**.

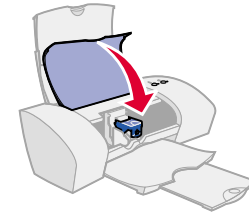

Note: To extend the life of your color print cartridge, print black and white documents with a black print cartridge.



Printer overview

Basic printing

Printing ideas

Maintenance

Troubleshooting

Notices

Index

Lexmark Z23

Your printer shipped with a color print cartridge (P/N 10N0026). You may also purchase a black cartridge (P/N 10N0016) separately. For more information, see **Ordering supplies**.

Your printer can print with one of the following cartridge configurations:

- A color cartridge by itself in the left carrier
- A black cartridge by itself in the right carrier
- Both a color and a black cartridge

To install a print cartridge:

a Open the cartridge carrier lid.

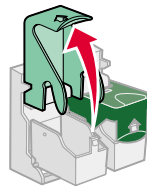

b Insert the print cartridge into the carrier.

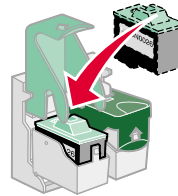

c Close the carrier lid completely.

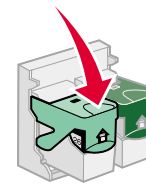

d Close the front cover. Continue with **Selecting the cartridge in the software**.

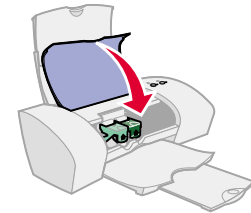

Note: To extend the life of your color print cartridge and improve printing speed, install a black print cartridge along with the color cartridge.



Printer overview

Basic printing

Printing ideas

Maintenance

Troubleshooting

Notices

Index

Lexmark Z33

Your printer came with two print cartridges: a color cartridge (P/N 10N0026) and a black cartridge (P/N 10N0016).

Your printer can print with one of the following cartridge configurations:

- A color cartridge by itself in the left carrier
- A black cartridge by itself in the right carrier
- Both a color and a black cartridge

To install a print cartridge:

a Open the cartridge carrier lid.

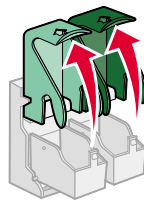

b Insert the print cartridge into the carrier.

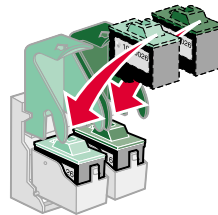

c Close the carrier lid completely.

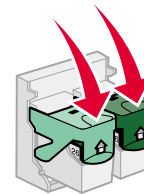

d Close the front cover. Continue with **Selecting the cartridge in the software**.

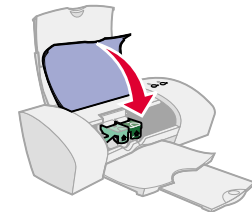

Printer overview

Basic printing

Printing ideas

Maintenance

Troubleshooting

Notices

Index

Selecting the cartridge in the software

- 1 Open the Lexmark Solution Center. For help, see [Lexmark Solution Center](#).
- 2 From the Cartridges tab, click Install/Change Cartridge.
- 3 Select the type of cartridge you installed.
- 4 Specify whether the cartridge is a new cartridge or an old cartridge (one that has been used before).
- 5 Click OK.
- 6 If you installed a new cartridge, continue with [Aligning the print cartridges](#).



Printer overview

Basic printing

Printing ideas

Maintenance

Troubleshooting

Notices

Index

Aligning the print cartridges

Normally, you align the print cartridges after installing or replacing a print cartridge. However, you may also need to align the print cartridges when:

- Characters are not aligned correctly at the left margin.
- Vertical lines appear “wavy.”

To align the print cartridges:

- 1 Load plain paper in the printer. For help, see [Load the paper](#).
- 2 Open the Lexmark Solution Center. For help, see [Lexmark Solution Center](#).



Printer overview

Basic printing

Printing ideas

Maintenance

Troubleshooting

Notices

Index

- 3 From the Cartridges tab, click Align Cartridges.

Your printer prints an alignment test page and the Align Cartridges dialog box appears. Depending on the cartridges you have installed, the number of alignment patterns will vary.

Note: If the alignment page doesn't print, make sure you completely removed the tape and sticker from the print cartridges.

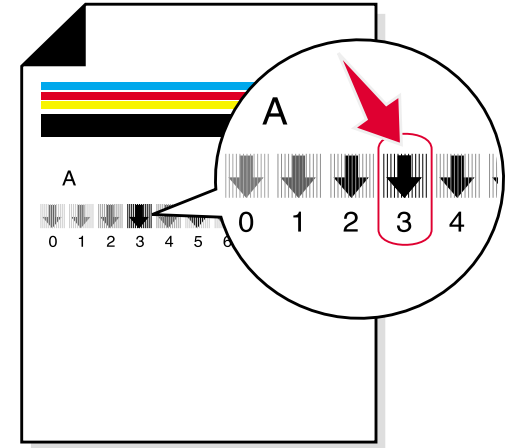

- 4 Each pattern has a number under it. Find the number under the darkest arrow. For example in alignment group A, number 3 is darkest.
- 5 In the Align Cartridges dialog box, type the pattern numbers from the printed test page.
- 6 Click OK.



Printer overview

Basic printing

Printing ideas

Maintenance

Troubleshooting

Notices

Index

Preserving the print cartridges

To ensure the longest life from your print cartridge and optimum performance from your printer:

- Keep a new print cartridge in its packaging until you are ready to install it.
- Do not remove a print cartridge from the printer except to replace, clean, or store it in the cartridge storage unit (Lexmark Z13 printer only) or another airtight container. For more information, see **Storing an extra print cartridge**. The print cartridge will not print correctly if left exposed for an extended period of time.

Lexmark's printer warranty does not cover repair of failures or damage caused by a refilled cartridge. Lexmark does not recommend use of refilled cartridges. Refilling cartridges can affect print quality and cause damage to the printer. For best results, use Lexmark supplies.



Printer overview

Basic printing

Printing ideas

Maintenance

Troubleshooting

Notices

Index

Storing an extra print cartridge

Note: This only applies to the Lexmark Z13 printer.

Attaching the print cartridge storage unit to the printer

- 1 Insert the tabs on the print cartridge storage unit into the slots on the back of your printer.
- 2 Snap the storage unit securely into place.

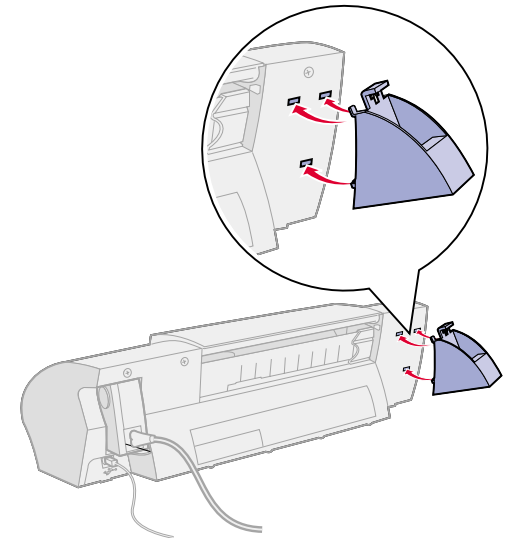

Printer overview

Basic printing

Printing ideas

Maintenance

Troubleshooting

Notices

Index

Inserting a print cartridge in the storage unit

- 1 Insert the extra print cartridge into the storage unit.
- 2 Push the cartridge down and then back to lock it into the storage unit.

Removing a print cartridge from the storage unit

- 1 Push the print cartridge down.
- 2 Pull the print cartridge toward you and out of the storage unit.

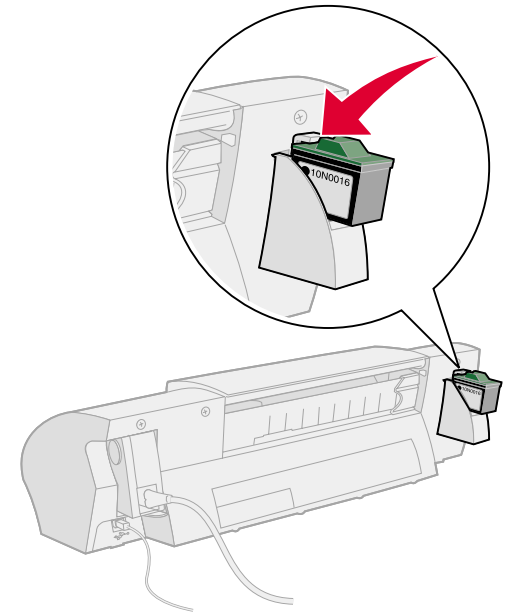

Printer overview

Basic printing

Printing ideas

Maintenance

Troubleshooting

Notices

Index

Ordering supplies

You can order supplies from the Lexmark Web site at www.lexmark.com.

Item:	Part number:
Color cartridge	10N0026
Black cartridge	10N0016
USB cable	12A2405
Power supply	Low Volt: 14D0300 High Volt: 14D0301



Printer overview

Basic printing

Printing ideas

Maintenance

Troubleshooting

Notices

Index

This section contains information to help you solve printing problems.

- **Solving general printing problems**
- **Solving printer software installation problems**
- **Understanding error messages and flashing lights**
- **Resolving unsuccessful or slow printing**
- **Clearing paper misfeeds or jams**
- **Solving specialty paper problems**
- **Improving print quality**
- **Reducing ink usage**



Printer overview

Basic printing

Printing ideas

Maintenance

Troubleshooting

Notices

Index

Solving general printing problems

When you have a printing problem, first make sure:

- The power supply is plugged into the printer and a properly grounded electrical outlet.
- The printer is turned on, and there are no lights blinking. For help, see **[Understanding error messages and flashing lights](#)**.
- The USB cable is securely attached to both the computer and the printer.
- You disconnect your printer from hubs or other devices, such as a scanner or a fax machine. Then connect the printer directly to your computer.
- The printer driver is installed correctly. For help, see **[Solving printer software installation problems](#)**.
- The paper is loaded correctly. For help, see **[Load the paper](#)**.
- The printer is set as the default printer. For help, see **[Printer is not queuing documents properly](#)**.



Printer overview

Basic printing

Printing ideas

Maintenance

Troubleshooting

Notices

Index

Printing a test page

- 1 Open the Lexmark Solution Center. For help, see [Lexmark Solution Center](#).
- 2 From the Cartridges tab, click Print a Test Page to verify that the printer is functioning properly.
 - If the test page prints, the printer software is communicating with the printer. Try printing your document again. If it still doesn't print, the operating system may not be sending the document to the printer software correctly.
 - If the test page does not print:
 - Check the USB cable connections.
 - Check the power supply connections.
 - Check that the printer daemon is running. For help, see [Restarting the printer daemon](#).



Printer overview

Basic printing

Printing ideas

Maintenance

Troubleshooting

Notices

Index

Restarting the printer daemon

Make sure lpd daemon is running. As root, type:

```
/etc/rc.d/init/lpd status
```

If lpd daemon is not running, as root, type the following at a command line to start the lpd daemon:

```
/usr/sbin/lpc restart all
```

or

```
/etc/rc.d/init.d/lpd stop
```

```
/etc/rc.d/init.d/lpd start
```



Printer overview

Basic printing

Printing ideas

Maintenance

Troubleshooting

Notices

Index

Solving printer software installation problems

If the printer software does not install properly, a communications error message appears when you try to print. You may need to uninstall, and then reinstall the printer software.

Uninstalling the printer software

- 1 Open a terminal window.
- 2 Type the following at a command line: `rpm -e filename`

where *filename* is the name of the rpm file containing your software. For example:
`rpm -e lexmarkz23-33-1.0-1.`

- 3 Continue with [Installing the printer software](#).

Installing the printer software

Note: Before you begin, make sure gzip is loaded on your system.

- 1 Download the printer software from the Lexmark Web site at www.lexmark.com, or find the file on your computer.
- 2 Open the directory where you downloaded the zipped file. The file will have a name similar to `CJLX13LE.tar.gz`



Printer overview

Basic printing

Printing ideas

Maintenance

Troubleshooting

Notices

Index

3 Type the following at the command line to decompress the file: `gunzip filename` where *filename* is the name of the file to be decompressed. For example:
`gunzip CJLX13LE.tar.gz`

4 At the command line, type: `tar -xvf filename.tar` where *filename* is the name of the tarred file you just decompressed. For example:
`tar -xvf CJLX13LE.tar`

5 At the command line, type: `rpm -i filename` where *filename* is the name of the RPM file. For example:
`rpm -i lexmarkz23-33-1.0-1.i386.rpm.`

Note: The RPM program copies all printer software information to the directory `/usr/local/lexmark/zxx/` where *Zxx* is your printer model. For example: `/usr/local/lexmark/z23-z33.`

6 Follow the instructions on your screen to complete the software installation.

7 Installing your printer involves installing and aligning the print cartridges. For help, see **Selecting the cartridge in the software.**



Printer overview

Basic printing

Printing ideas

Maintenance

Troubleshooting

Notices

Index

Understanding error messages and flashing lights

Use this section to help you understand the error messages from your printer software and the blinking lights on your printer.

Paper Jam message

If the Paper Feed light is blinking, you may have a paper jam. For help, see [Clearing paper misfeeds or jams](#).

Ink Low message

A print cartridge is running out of ink. Purchase a new print cartridge. For help, see [Ordering supplies](#). For help installing a new cartridge, see [Replacing a print cartridge](#).



Printer overview

Basic printing

Printing ideas

Maintenance

Troubleshooting

Notices

Index

The Paper Feed light is blinking

- If the printer is out of paper:
 - a Load paper. For help, see [Load the paper](#).
 - b Press the Paper Feed button.
- If the paper is jammed, see [Clearing paper misfeeds or jams](#).

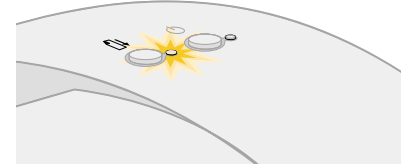

The Power light is blinking

The print cartridge carrier is stalled.

- 1 Check your screen for error messages.
- 2 Turn the printer off.
- 3 Wait a few seconds, and turn the printer back on.



Printer overview

Basic printing

Printing ideas

Maintenance

Troubleshooting

Notices

Index

Resolving unsuccessful or slow printing

Click the topic that best describes your problem.

- **Bidirectional communication problems**
- **Printer is plugged in but doesn't print**
- **Test page does not print**
- **Printer ejects a blank page after appearing to print**
- **Printer prints very slowly**
- **Printer is not queuing documents properly**

Bidirectional communication problems

If your printer doesn't print, your printer and computer may not be communicating properly. The following events also indicate bidirectional communication problems:

- A message appears on your computer screen indicating that your printer cannot establish bidirectional communication with your computer.
- The print cartridge ink level indicators on the Cartridges tab are shaded.
- Error messages (such as Paper Out) and job progress information do not appear on the computer screen.



Printer overview

Basic printing

Printing ideas

Maintenance

Troubleshooting

Notices

Index

Before proceeding, verify that:

- The printer software has been installed correctly. For help, see **Solving printer software installation problems**.
- The USB cable is securely attached to both the printer and the computer.
- The printer is plugged into a properly grounded electrical outlet and is on.
- Remove any extra devices, such as a scanner or hub, and connect the printer directly to the USB port.

Printer is plugged in but doesn't print

Make sure:

- The printer is turned on.
- The paper is loaded correctly. For help, see **Basic printing**.
- Bidirectional communication is established between your printer and computer. For help, see **Bidirectional communication problems**.
- The printer is set as the default printer. For help, see **Solving general printing problems**.
- The print job is not being held in the print queue. For help, see **Printer is not queuing documents properly**.



Printer overview

Basic printing

Printing ideas

Maintenance

Troubleshooting

Notices

Index

Try **Printing a test page**. If the test page prints, the printer is functioning properly. If it does not print, see **Test page does not print**.

Test page does not print

Make sure:

- The print cartridge is properly installed. For help, see **Replacing a print cartridge**.
- The printer is set as the default printer. For help, see **Solving general printing problems**.
- The paper is loaded correctly. For help, see **Load the paper**.

Printer ejects a blank page after appearing to print

Make sure:

- Your printer is set as the default printer. For help, see **Solving general printing problems**.
- You remove the sticker and transparent tape from the print cartridge. For help, see **Replacing a print cartridge**.
- Your print cartridge does not have clogged nozzles. **Clean the print cartridge nozzles**.



Printer overview

Basic printing

Printing ideas

Maintenance

Troubleshooting

Notices

Index

Printer prints very slowly

- Close software applications not in use.
- Check the document you are printing. Photos and graphics may take longer to print than regular text.
- Choose Quick Print or Normal print quality for faster speed. Your document takes longer to print when you use a higher quality setting.
- Check your computer resources. Consider increasing the virtual memory for your computer or consider purchasing more random access memory (RAM).

Printer is not queuing documents properly

- Send the print job to the correct printer. For help, see [Print your document](#).
- Check the name of your printer by looking at the names in the spool directory (*/var/spool/lpd*) or in the printcap file (*/etc/printcap*).
- In the */etc/printcap* file, make sure `:lp` is pointing to the correct port. For example, if your printer is attached to your first USB port, it is usually defined as */dev/usb/usb/lp0*.

Note: You can only print to a USB port if your Linux kernel has USB support. For help, refer to your Linux documentation.



Printer overview

Basic printing

Printing ideas

Maintenance

Troubleshooting

Notices

Index

- Make sure your printer is the default printer. The default printer is the one with *lp* in the first line of the entry for the printer in the */etc/printcap* file.
- Make sure *lpd* daemon is running. For help, see **Restarting the printer daemon**.



Printer overview

Basic printing

Printing ideas

Maintenance

Troubleshooting

Notices

Index

Clearing paper misfeeds or jams

Click the topic that best describes your problem.

- **Paper misfeeds or multiple sheets feed through the printer**
- **The printer does not feed envelopes or specialty paper**
- **The printer has a paper jam**

Paper misfeeds or multiple sheets feed through the printer

Make sure:

- Your paper is recommended for inkjet printers.
- You do not load too much paper in the sheet feeder. Depending on the thickness of your paper, the sheet feeder can hold up to 100 sheets of paper or 10 mm (0.39 in.).
- You do not force the paper down into the printer when you load it. For example, A4 size paper should extend above the top of the paper support. (Letter size paper should align with the top of the paper support.) Make sure the paper support is fully extended.
- The paper guide is against the left side of the paper.
- The paper guide does not cause the paper to bow in the sheet feeder.



Printer overview

Basic printing

Printing ideas

Maintenance

Troubleshooting

Notices

Index

- The printer is on a flat, level surface.
- Your settings are correct in the driver. For help, see [Customize the print settings](#).

The printer does not feed envelopes or specialty paper

Make sure:

- Your printer will feed plain paper. For help, see [Load the paper](#).
If regular paper feeds without problems, load the envelopes or specialty paper vertically against the right side of the sheet feeder. Make sure the paper guide is against the left side of the envelopes. For help, see [Load the envelopes](#).
- The appropriate envelope or specialty paper size is selected in the printer software. For help, see [Printing ideas](#).
- You are using a specialty paper or envelope size supported by your printer.
- Your software application is designed to print envelopes. For help, check the documentation that came with your software application.
- Your stack of paper in the sheet feeder does not exceed 10 mm (0.39 in.) in height.
- You loaded the envelopes, or specialty paper correctly. For help, see [Load the envelopes](#) or [Load the paper](#).
- If the envelope or specialty paper is jammed, see [The printer has a paper jam](#).



Printer overview

Basic printing

Printing ideas

Maintenance

Troubleshooting

Notices

Index

The printer has a paper jam

If the paper is lodged too far into the printer and can't be removed:

- 1 Turn the printer off.
- 2 Turn the printer back on.
- 3 If the printer does not eject the page:
 - a Turn the printer off.
 - b Pull firmly on the paper to remove it. If you cannot reach the paper, raise the front cover and pull the paper out of the printer.
 - c Close the front cover.
 - d Turn the printer on.
- 4 Resend your document to print.



Printer overview

Basic printing

Printing ideas

Maintenance

Troubleshooting

Notices

Index

Solving specialty paper problems

Use this section to help you solve problems with specialty paper.

Glossy or photo papers or transparencies stick together

- Make sure the paper is loaded correctly and the correct settings are selected in the printer software. For help, see [Printing photos](#) or [Printing transparencies](#).
- Remove each page as it exits the printer and let it dry before stacking.
- Use a photo paper or transparency designed for inkjets.

Transparencies or photos contain white lines

- Select a higher Quality/Speed setting, such as Better or Best. For help, see [Customize the print settings](#). As you increase the print Quality/Speed, the document takes longer to dry. Too much handling before they dry completely can cause smearing.
- [Clean the print cartridge nozzles](#).

Envelopes or specialty papers misfeed

See, [The printer does not feed envelopes or specialty paper](#)



Printer overview

Basic printing

Printing ideas

Maintenance

Troubleshooting

Notices

Index

Improving print quality

Click the topic that best describes your problem.

- **Clean the print cartridge nozzles**
- **Wipe the print nozzles and contacts**
- **Print is too dark or smudged**
- **Vertical straight lines are not smooth**
- **Print smears on the page**
- **Printed pages have alternating bands of light and dark print**
- **Print quality is poor at the edges of the page**
- **Printed characters are improperly formed or misaligned**
- **Colors on the printout are faded or they differ from colors on the screen**
- **Characters are missing or unexpected**

Clean the print cartridge nozzles

Cleaning the print cartridge nozzles forces ink through the nozzles to clear any that are clogged. A test page prints so you can see if the cleaning process is a success.

Clean the print nozzles when:

- Characters are not printing completely.
- White dashes appear in graphics or printed text.



Printer overview

Basic printing

Printing ideas

Maintenance

Troubleshooting

Notices

Index

- Print is smudged or too dark.
- Colors do not print correctly.

To clean the print nozzles:

- 1 Load plain paper in the printer. For help, see **Load the paper**.
- 2 From your desktop, open the Lexmark Solution Center. For help, see **Lexmark Solution Center**.
- 3 Click Cartridges.
- 4 Click Clean Print Nozzles.



Printer overview

Basic printing

Printing ideas

Maintenance

Troubleshooting

Notices

Index

The printer prints a nozzle test pattern similar to the one shown:

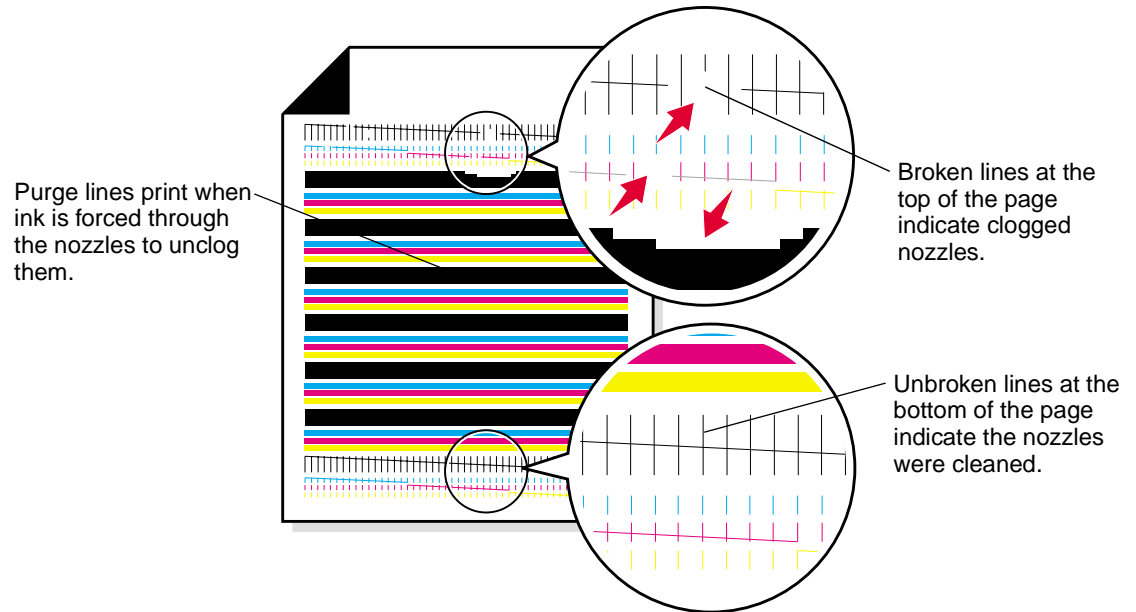

Printer overview

Basic printing

Printing ideas

Maintenance

Troubleshooting

Notices

Index

When you install a:	These purge lines print:
Black cartridge	1 black purge line
Color cartridge	3 purge lines: cyan, magenta, and yellow
Black and color cartridge	4 purge lines: cyan, magenta, yellow, and black

Note: If the correct number of purge lines did not print, replace your print cartridge. For help, see [Replacing a print cartridge](#).

- 5 Compare the lines above the purge lines to the lines below. Look for a break in the lines. A broken line indicates clogged nozzles.

If the second set of lines has breaks, clean the print nozzles up to two more times.

If the lines are still broken, [Wipe the print nozzles and contacts](#).



Printer overview

Basic printing

Printing ideas

Maintenance

Troubleshooting

Notices

Index

Wipe the print nozzles and contacts

If print quality does not improve after you **Clean the print cartridge nozzles**, there may be dried ink on the print nozzles or contacts.

- 1 Remove the print cartridge. For help, see **Removing the used cartridge**.
- 2 Dampen a clean, lint-free cloth with water.

a Hold the cloth against the nozzles for about three seconds. Gently blot and wipe in one direction.

b Use another clean section of cloth. Hold the damp cloth against the contacts for about three seconds. Gently blot and wipe in one direction.

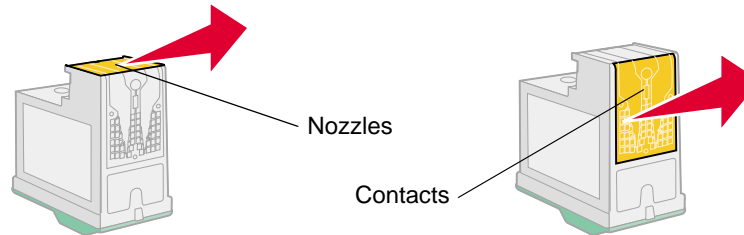

- 3 Reinstall the print cartridge, and then clean the nozzles again. For help, see **Clean the print cartridge nozzles**.



Printer overview

Basic printing

Printing ideas

Maintenance

Troubleshooting

Notices

Index

Print is too dark or smudged

- Make sure the paper is straight and not wrinkled.
- Let the ink dry before handling the paper.
- Make sure the Type setting in the printer software matches the type of paper loaded.
- Select a lower Quality/Speed setting, such as Quick Print or Normal. For help, see [Customize the print settings](#).
- [Clean the print cartridge nozzles](#).

Vertical straight lines are not smooth

- Select a higher Quality/Speed setting. For help, see [Customize the print settings](#).
- Try [Aligning the print cartridges](#).
- [Clean the print cartridge nozzles](#).



Printer overview

Basic printing

Printing ideas

Maintenance

Troubleshooting

Notices

Index

Print smears on the page

- When loading the paper, make sure the print side is facing you. For help, see [Load the paper](#).
- Remove each page as it exits and let it dry before stacking.
- [Clean the print cartridge nozzles](#).

Printed pages have alternating bands of light and dark print

- Select a higher Quality/Speed setting, such as Better or Best. For help, see [Customize the print settings](#).
- Make sure you have established bidirectional communication between your printer and computer. For help, see [Bidirectional communication problems](#).



Printer overview

Basic printing

Printing ideas

Maintenance

Troubleshooting

Notices

Index

Print quality is poor at the edges of the page

Like other printers, your printer cannot print on the extreme left, right, top, or bottom edges of a page. Here are the minimum margins for your printer:

Margin	Minimum setting
Left and Right	<ul style="list-style-type: none">• 6.35 mm (0.25 in.) for most paper sizes• 3.37 mm (0.133 in.) for A4
Top	1.7 mm (0.067 in.)
Bottom	<ul style="list-style-type: none">• 12.7 mm (0.5 in.) for most print jobs• 19.0 mm (0.75 in.) for Maximum quality

Printed characters are improperly formed or misaligned

- Try **Aligning the print cartridges**.
- **Clean the print cartridge nozzles**.



Printer overview

Basic printing

Printing ideas

Maintenance

Troubleshooting

Notices

Index

Colors on the printout are faded or they differ from colors on the screen

- A print cartridge may be out or low on ink. Try [Replacing a print cartridge](#).
- Use a different brand of paper. Every paper brand accepts ink differently and prints with slight color variations.
- Your printer may have bidirectional communication problems. For help, see [Bidirectional communication problems](#).
- [Clean the print cartridge nozzles](#).

Characters are missing or unexpected

- Make sure your printer software is selected as the default printer. For help, see [Solving general printing problems](#).
- Your printer may have bidirectional communication problems. For help, see [Bidirectional communication problems](#).



Printer overview

Basic printing

Printing ideas

Maintenance

Troubleshooting

Notices

Index

Reducing ink usage

Choose a lower print quality:

- 1 From Printer Settings, choose the Quality/Copies tab.
- 2 From the Quality/Speed area, select a lower Quality/Speed setting. As you lower the print quality, the amount of ink you use decreases.
- 3 Click OK.

To reduce the amount of color ink you use, print color documents in black and white. For help, see [Printing color images in black and white](#).



Printer overview

Basic printing

Printing ideas

Maintenance

Troubleshooting

Notices

Index

This section contains information regarding legal notices.

- **Edition notice**
- **Trademarks**
- **Cautions and warnings**
- **Electronic emission notices**



Printer overview

Basic printing

Printing ideas

Maintenance

Troubleshooting

Notices

Index

Edition notice

Edition: January 2001

The following paragraph does not apply to any country where such provisions are inconsistent with local law: LEXMARK INTERNATIONAL, INC., PROVIDES THIS PUBLICATION “AS IS” WITHOUT WARRANTY OF ANY KIND, EITHER EXPRESS OR IMPLIED, INCLUDING, BUT NOT LIMITED TO, THE IMPLIED WARRANTIES OF MERCHANTABILITY OR FITNESS FOR A PARTICULAR PURPOSE. Some states do not allow disclaimer of express or implied warranties in certain transactions; therefore, this statement may not apply to you.

This publication could include technical inaccuracies or typographical errors. Changes are periodically made to the information herein; these changes will be incorporated in later editions. Improvements or changes in the products or the programs described may be made at any time.

Comments about this publication may be addressed to Lexmark International, Inc., Department F95/032-2, 740 West New Circle Road, Lexington, Kentucky 40550, U.S.A. In the United Kingdom and Eire, send to Lexmark International Ltd., Marketing and Services Department, Westhorpe House, Westhorpe, Marlow Bucks SL7 3RQ. Lexmark may use or distribute any of the information you supply in any way it believes appropriate without incurring any obligation to you. You can purchase additional copies of publications related to



Printer overview

Basic printing

Printing ideas

Maintenance

Troubleshooting

Notices

Index

this product by calling 1-800-553-9727. In the United Kingdom and Eire, call 0628-481500. In other countries, contact your point of purchase.

References in this publication to products, programs, or services do not imply that the manufacturer intends to make these available in all countries in which it operates. Any reference to a product, program, or service is not intended to state or imply that only that product, program, or service may be used. Any functionally equivalent product, program, or service that does not infringe any existing intellectual property right may be used instead. Evaluation and verification of operation in conjunction with other products, programs, or services, except those expressly designated by the manufacturer, are the user's responsibility.

© Copyright 2001 Lexmark International, Inc.
All rights reserved.

UNITED STATES GOVERNMENT RESTRICTED RIGHTS

This software and documentation are provided with RESTRICTED RIGHTS. Use, duplication or disclosure by the Government is subject to restrictions as set forth in subparagraph (c)(1)(ii) of the Rights in Technical Data and Computer Software clause at DFARS 252.227-7013 and in applicable FAR provisions: Lexmark International, Inc., Lexington, KY 40550.



Printer overview

Basic printing

Printing ideas

Maintenance

Troubleshooting

Notices

Index

Trademarks

Lexmark and Lexmark with diamond design are trademarks of Lexmark International, Inc., registered in the United States and/or other countries.

Color Jetprinter is a trademark of Lexmark International, Inc.

Other trademarks are the property of their respective owners.



Printer overview

Basic printing

Printing ideas

Maintenance

Troubleshooting

Notices

Index

Cautions and warnings

CAUTION! A caution identifies something that might cause you harm.

Warning: A warning identifies something that might damage your printer hardware or software.



Printer overview

Basic printing

Printing ideas

Maintenance

Troubleshooting

Notices

Index

Electronic emission notices

Federal Communications Commission (FCC) compliance information statement

The Lexmark Z13 Color Jetprinter, Type 4104; Lexmark Z23 Color Jetprinter, Type 4105; and Lexmark Z33 Color Jetprinter, Type 4105 has been tested and found to comply with the limits for a Class B digital device, pursuant to Part 15 of the FCC Rules. Operation is subject to the following two conditions: (1) these devices may not cause harmful interference, and (2) these devices must accept any interference received, including interference that may cause undesired operation.

The FCC Class B limits are designed to provide reasonable protection against harmful interference in a residential installation. This equipment generates, uses and can radiate radio frequency energy and, if not installed and used in accordance with the instructions, may cause harmful interference to radio communications. However, there is no guarantee that interference will not occur in a particular installation. If this equipment does cause harmful interference to radio or television reception, which can be determined by turning the equipment off and on, the user is encouraged to try to correct the interference by one or more of the following measures:

- Reorient or relocate the receiving antenna.
- Increase the separation between the equipment and receiver.



Printer overview

Basic printing

Printing ideas

Maintenance

Troubleshooting

Notices

Index

- Connect the equipment into an outlet on a circuit different from that to which the receiver is connected.
- Consult your point of purchase or service representative for additional suggestions.

The manufacturer is not responsible for any radio or television interference caused by using other than recommended cables or by unauthorized changes or modifications to this equipment. Unauthorized changes or modifications could void the user's authority to operate this equipment.

Note: To assure compliance with FCC regulations on electromagnetic interference for a Class B computing device, use a properly shielded and grounded cable such as Lexmark part number 12A2405. Use of a substitute cable not properly shielded and grounded may result in a violation of FCC regulations.

Any questions regarding this compliance information statement should be directed to:

Director of Lab Operations
Lexmark International, Inc.
740 West New Circle Road
Lexington, KY 40550
(859) 232-3000



Printer overview

Basic printing

Printing ideas

Maintenance

Troubleshooting

Notices

Index

Industry Canada compliance statement

This Class B digital apparatus meets all requirements of the Canadian Interference-Causing Equipment Regulations.

Avis de conformité aux normes d'Industrie Canada

Cet appareil numérique de la classe B respecte toutes les exigences du Règlement sur le matériel brouilleur du Canada.

European Community (EC) directives conformity

This product is in conformity with the protection requirements of EC Council directives 89/336/EEC and 73/23/EEC on the approximation and harmonization of the laws of the Member States relating to electromagnetic compatibility and safety of electrical equipment designed for use within certain voltage limits.

A declaration of conformity with the requirements of the directives has been signed by the Director of Manufacturing and Technical Support, Lexmark International, S.A., Boigny, France.

The United Kingdom Telecommunications Act 1984

This apparatus is approved under the approval number NS/G/1234/J/100003 for the indirect connections to the public telecommunications systems in the United Kingdom.



Printer overview

Basic printing

Printing ideas

Maintenance

Troubleshooting

Notices

Index

A

aligning print cartridges 50

B

banding 79

banner paper 40

bidirectional communication
problems 64

black cartridge part number 45

blinking lights

Paper Feed 63

Power 63

C

cards 22

cartridge storage unit 54

cartridges, print

aligning 50

part numbers 45

preserving 52

removing 44

wiping 77

cautions and warnings 87

characters, misformed 80

coated paper 16

color cartridge part number 45

conserving color ink 27

contacts, wiping 77

custom size paper 31

customizing settings

driver 6

Page Setup dialog box 7

D

dark or smudged print 78

default settings 5

driver, printer 5

E

envelopes 24

error messages

Ink Low 62

Paper Jam 62

F

flashing lights 62

foils 35

G

glossy paper 16

greeting cards 22

I

improving print quality 73

index cards 22

Ink Low message 62

installing printer software 60

intermittent printing 79

iron-on transfers 33

L

labels 29

last page first 6

Lexmark Solution Center 8

lights

flashing 62

Paper Feed 63

Power 63

loading

banner paper 40

cards 22

coated paper 16

custom size paper 31

Printer overview

Basic printing

Printing ideas

Maintenance

Troubleshooting

Notices

Index

envelopes 24
foils 35
glossy paper 16
greeting cards 22
index cards 22
iron-on transfers 33
labels 29
photo cards 22
photo paper 16
plain paper 11
postcards 22
premium paper 19
specialty paper 11
transparencies 35
t-shirt transfers 33

M

margins, minimum settings 80
messages, error
 Ink Low 62
 Paper Jam 62

N

notices
 cautions and warnings 87
 edition notice 84

electronic emissions
 notices 88
 trademarks 86
nozzle test 74
nozzles, print
 cleaning 73
 wiping 77

O

ordering supplies 55

P

page settings, changing 7
Paper Feed light 63
paper guide 11
paper jam 62
Paper Jam message 62
paper jam, clearing 71
paper loading 11
Paper Setup tab 7
paper support 11
part numbers
 black cartridge 45
 color cartridge 45
 power supply 55
 USB cable 55

photo cards 22
photo paper 16
plain paper 11
postcards 22
power supply 57
premium paper 19
print cartridge contacts,
 wiping 77
print cartridges
 aligning 50
 cleaning 73
 part numbers 45
 preserving 52
 removing 44
print color images in black and
 white 27
print in reverse order 38
print last page first 38
print nozzles
 cleaning 73
 wiping 77
print quality, troubleshooting 73
Print Style tab 7
printer daemon 59
printer driver 5
printer parts 3



Printer overview

Basic printing

Printing ideas

Maintenance

Troubleshooting

Notices

Index

printer software
driver 5
installing 60
Lexmark Solution Center 5
uninstalling 60

printing
color images in black and
white 27
in reverse order 38
with less ink 82

printing problems
color quality 81
error messages 62
flashing lights 62
general 57
paper feeding 69
print quality 73
software 60
specialty paper 72

purge lines 76

Q

Quality/Copies tab 6

R

reducing ink usage 82
release tab 11
removing print cartridges 44

S

setting recommendations
banner paper 40
cards 22
coated paper 16
custom size paper 31
default 5
envelopes 24
foils 35
glossy paper 16
greeting cards 22
index cards 22
iron-on transfers 33
labels 29
photo cards 22
photo paper 16
postcards 22
premium paper 19
print color images in black
and white 27

print last page first 38
transparencies 35
t-shirt transfers 33
settings, default 5
sheet feeder 11
software, printer 5
specialty paper 11
supplies, ordering 55

T

test page 58
alignment 51
does not print 66
transfers, iron-on 33
transparencies 35
troubleshooting
error messages 62
flashing lights 62
general 57
paper feeding 69
print quality 73
software 60
specialty paper 72
t-shirt transfers 33



Printer overview

Basic printing

Printing ideas

Maintenance

Troubleshooting

Notices

Index

U

uninstalling printer software 60

USB cable 65

