



C734 and C736 Series

User's Guide

March 2012

www.lexmark.com

Machine type(s):

5026

Model(s):

210, 230, 280, 410, 430, 480

Contents

- Safety information.....5**
- Learning about the printer.....7**
 - Thank you for choosing this printer!.....7
 - Finding information about the printer.....7
 - Selecting a location for the printer.....8
 - Printer configurations.....10
 - Using the security lock feature.....12
 - Understanding the printer control panel.....12
- Additional printer setup.....14**
 - Installing internal options.....14
 - Installing hardware options.....30
 - Attaching cables.....32
 - Verifying printer setup.....33
 - Setting up the printer software.....34
 - Setting up wireless printing.....36
 - Installing the printer on a wired network.....41
 - Changing port settings after installing a new network Internal Solutions Port.....43
 - Setting up serial printing.....45
- Minimizing your printer's environmental impact.....47**
 - Saving paper and toner.....47
 - Saving energy.....48
 - Recycling.....51
- Loading paper and specialty media.....52**
 - Setting the paper size and type.....52
 - Loading the paper tray.....52
 - Loading the multipurpose feeder.....55
 - Linking and unlinking trays.....58
- Paper and specialty media guidelines.....60**
 - Paper guidelines.....60
 - Supported paper sizes, types, and weights.....62

Printing.....	66
Printing a document.....	66
Printing specialty documents.....	67
Printing confidential and other held jobs.....	69
Printing from a flash drive.....	71
Printing photos from a PictBridge-enabled digital camera.....	72
Printing information pages.....	72
Canceling a print job.....	73
Printing in black and white.....	75
Using Max Speed and Max Yield.....	75
Understanding printer menus.....	76
Menus list.....	76
Supplies menu.....	77
Paper menu.....	78
Reports menu.....	88
Network/Ports menu.....	89
Security menu.....	104
Settings menu.....	108
Help menu.....	128
Maintaining the printer.....	130
Cleaning the exterior of the printer.....	130
Cleaning the printhead lenses.....	130
Storing supplies.....	132
Checking the status of supplies.....	132
Ordering supplies.....	133
Replacing supplies.....	134
Moving the printer.....	143
Administrative support.....	145
Finding advanced networking and administrator information.....	145
Using the Embedded Web Server.....	145
Checking the virtual display.....	145
Checking the device status.....	145
Setting up e-mail alerts.....	146

Viewing reports.....	146
Restoring the factory default settings.....	146
Copying printer settings to other printers.....	147
Clearing jams.....	148
Avoiding jams.....	148
Accessing jam areas.....	148
200–201 paper jams.....	149
202 paper jam.....	150
203 and 230 paper jams.....	153
24x paper jam.....	155
250 paper jam.....	156
Troubleshooting.....	157
Understanding printer messages.....	157
Solving basic problems.....	169
Solving printing problems.....	170
Solving option problems.....	173
Solving paper feed problems.....	176
Solving print quality problems.....	177
Solving color quality problems.....	190
Contacting Customer Support.....	193
Notices.....	194
Product information.....	194
Edition notice.....	194
Power consumption.....	198
Index.....	208

Safety information

Connect the power cord to a properly grounded electrical outlet that is near the product and easily accessible.

Do not place or use this product near water or wet locations.

 **CAUTION—POTENTIAL INJURY:** This product uses a laser. Use of controls or adjustments or performance of procedures other than those specified herein may result in hazardous radiation exposure.

This product uses a printing process that heats the print media, and the heat may cause the media to release emissions. You must understand the section in your operating instructions that discusses the guidelines for selecting print media to avoid the possibility of harmful emissions.

Use care when you replace a lithium battery.

 **CAUTION—POTENTIAL INJURY:** There is a danger of explosion if a lithium battery is incorrectly replaced. Replace it only with the same or an equivalent type of lithium battery. Do not recharge, disassemble, or incinerate a lithium battery. Discard used batteries according to the manufacturer's instructions and local regulations.

 **CAUTION—HOT SURFACE:** The inside of the printer might be hot. To reduce the risk of injury from a hot component, allow the surface to cool before touching.

 **CAUTION—POTENTIAL INJURY:** The printer weight is greater than 18 kg (40 lb) and requires two or more trained personnel to move it safely.

 **CAUTION—POTENTIAL INJURY:** Before moving the printer, follow these guidelines to avoid personal injury or printer damage:

- Turn the printer off using the power switch, and then unplug the power cord from the wall outlet.
- Disconnect all cords and cables from the printer before moving it.
- Lift the printer off the optional drawer, and set it aside instead of trying to lift the drawer and printer at the same time.

Note: Use the handholds located on both sides and rear of the printer to lift it off the optional drawer.

Use only the power cord provided with this product or the manufacturer's authorized replacement.

 **CAUTION—SHOCK HAZARD:** If you are accessing the system board or installing optional hardware or memory devices sometime after setting up the printer, then turn the printer off, and unplug the power cord from the wall outlet before continuing. If you have any other devices attached to the printer, then turn them off as well, and unplug any cables going into the printer.

 **CAUTION—SHOCK HAZARD:** Make sure that all external connections (such as Ethernet and telephone system connections) are properly installed in their marked plug-in ports.

This product is designed, tested, and approved to meet strict global safety standards with the use of specific manufacturer's components. The safety features of some parts may not always be obvious. The manufacturer is not responsible for the use of other replacement parts.

 **CAUTION—POTENTIAL INJURY:** Do not cut, twist, bind, crush, or place heavy objects on the power cord. Do not subject the power cord to abrasion or stress. Do not pinch the power cord between objects such as furniture and walls. If any of these things happen, a risk of fire or electrical shock results. Inspect the power cord regularly for signs of such problems. Remove the power cord from the electrical outlet before inspecting it.

Refer service or repairs, other than those described in the user documentation, to a professional service person.

 **CAUTION—SHOCK HAZARD:** To avoid the risk of electric shock when cleaning the exterior of the printer, unplug the power cord from the wall outlet and disconnect all cables from the printer before proceeding.

 **CAUTION—SHOCK HAZARD:** Do not use the fax feature during a lightning storm. Do not set up this product or make any electrical or cabling connections, such as the fax feature, power cord, or telephone, during a lightning storm.

 **CAUTION—TIPPING HAZARD:** Floor-mounted configurations require additional furniture for stability. You must use either a printer stand or printer base if you are using a high-capacity input tray, a duplex unit and an input option, or more than one input option. If you purchased a multifunction printer (MFP) that scans, copies, and faxes, you may need additional furniture. For more information, see www.lexmark.com/multifunctionprinters.

SAVE THESE INSTRUCTIONS.

Learning about the printer

Thank you for choosing this printer!

We've worked hard to make sure it will meet your needs.

To start using your new printer right away, use the setup materials that came with the printer, and then skim the *User's Guide* to learn how to perform basic tasks. To get the most out of your printer, read the *User's Guide* carefully, and make sure you check the latest updates on our Web site.

We're committed to delivering performance and value with our printers, and we want to make sure you're satisfied. If you do encounter any problems along the way, one of our knowledgeable support representatives will be delighted to help you get back on track fast. And if you find something we could do better, please let us know. After all, you are the reason we do what we do, and your suggestions help us do it better.

Finding information about the printer

What are you looking for?	Find it here
Initial setup instructions: <ul style="list-style-type: none"> • Connecting the printer • Installing the printer software 	Setup documentation—The setup documentation came with the printer and is also available on the Lexmark Web site at http://support.lexmark.com .
Additional setup and instructions for using the printer: <ul style="list-style-type: none"> • Selecting and storing paper and specialty media • Loading paper • Performing printing depending on your printer model • Configuring printer settings • Viewing and printing documents and photos • Setting up and using printer software • Setting up and configuring the printer on a network, depending on your printer model • Caring for and maintaining the printer • Troubleshooting and solving problems 	<i>User's Guide</i> —The <i>User's Guide</i> is available on the <i>Software and Documentation CD</i> . For updates, check our Web site at http://support.lexmark.com .
Help using the printer software	Windows or Mac Help—Open a printer software program or application, and then click Help . Click  to view context-sensitive information. Notes: <ul style="list-style-type: none"> • The Help installs automatically with the printer software. • The printer software is located in the printer Program folder or on the desktop, depending on your operating system.

What are you looking for?	Find it here
<p>The latest supplemental information, updates, and technical support:</p> <ul style="list-style-type: none"> • Documentation • Driver downloads • Live chat support • E-mail support • Telephone support 	<p>Lexmark Support Web site— http://support.lexmark.com</p> <p>Note: Select your region, and then select your product to view the appropriate support site.</p> <p>Support telephone numbers and hours of operation for your region or country can be found on the Support Web site or on the printed warranty that came with your printer.</p> <p>Record the following information (located on the store receipt and the back of the printer), and have it ready when you contact support so that they may serve you faster:</p> <ul style="list-style-type: none"> • Machine Type number • Serial number • Date purchased • Store where purchased
<p>Warranty information</p>	<p>Warranty information varies by country or region:</p> <ul style="list-style-type: none"> • In the US—See the Statement of Limited Warranty included with this printer, or at http://support.lexmark.com. • Rest of the world—See the printed warranty that came with your printer.

Selecting a location for the printer



CAUTION—POTENTIAL INJURY: The printer weight is greater than 18 kg (40 lb) and requires two or more trained personnel to lift it safely.

When selecting a location for the printer, leave enough room to open trays, covers, and doors. If you plan to install any options, leave enough room for them also. It is important to:

- Make sure airflow in the room meets the latest revision of the ASHRAE 62 standard.
- Provide a flat, sturdy, and stable surface.
- Keep the printer:
 - Away from the direct airflow of air conditioners, heaters, or ventilators
 - Free from direct sunlight, humidity extremes, or temperature fluctuations
 - Clean, dry, and free of dust
- Allow the following recommended amount of space around the printer for proper ventilation:

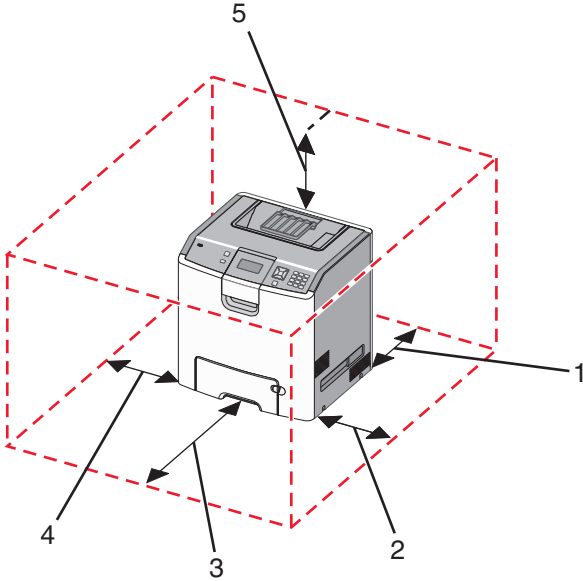

1	152.4 mm (6.0 in.)
2	101.6 mm (4.0 in.)
3	609.6 mm (24.0 in.)
4	152.4 mm (6.0 in.)
5	304.8 mm (12.0 in.)

Printer configurations

Basic model

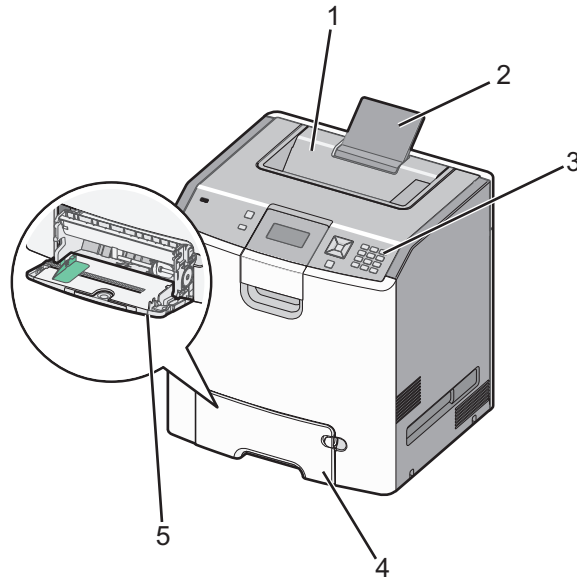

1	Standard exit bin
2	Paper support
3	Printer control panel
4	Standard 550-sheet tray (Tray 1)
5	Multipurpose feeder

Configured models

CAUTION—TIPPING HAZARD: Floor-mounted configurations require additional furniture for stability. You must use either a printer stand or printer base if you are using a high-capacity input tray, a duplex unit and an input option, or more than one input option. If you purchased a multifunction printer (MFP) that scans, copies, and faxes, you may need additional furniture. For more information, see www.lexmark.com/multifunctionprinters.

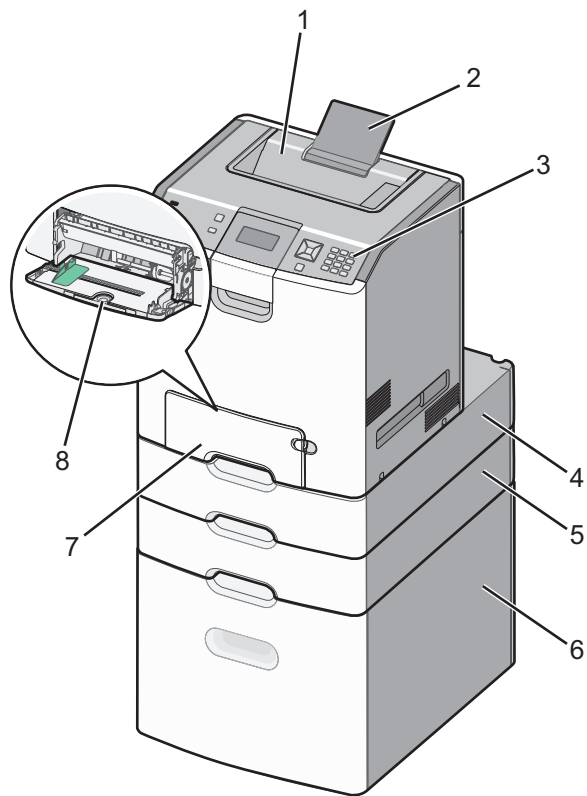

1	Standard exit bin
2	Paper support
3	Printer control panel
4	Optional 550-sheet specialty media drawer
5	Optional 550-sheet tray
6	Optional 2,000-sheet tray
7	Standard 550-sheet tray (Tray 1)
8	Multipurpose feeder

Using the security lock feature

The printer is equipped with a security lock feature. When a lock compatible with most laptop computers is attached, the printer is locked. Once locked, the metal plate and the system board cannot be removed. Attach a security lock to the printer in the location shown.

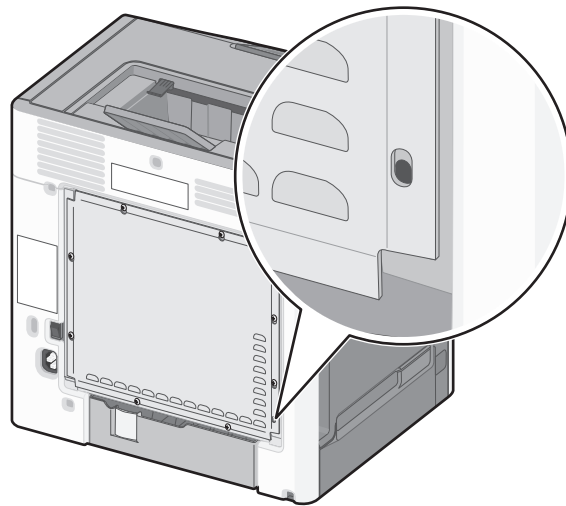

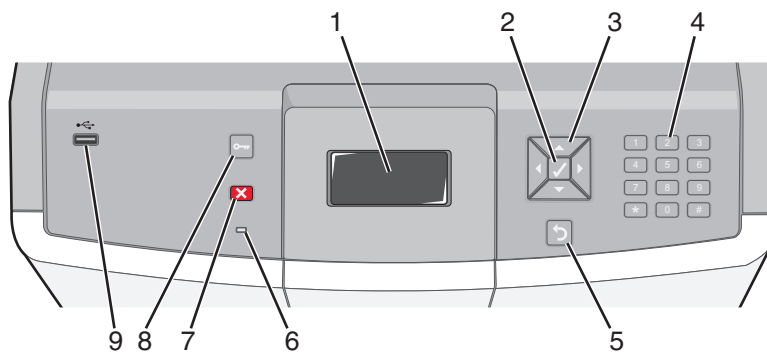

Understanding the printer control panel



Control panel item		Description
1	Display	The display shows messages and pictures that communicate the status of the printer.
2	Select	Pressing <input checked="" type="checkbox"/> initiates action on a menu item.

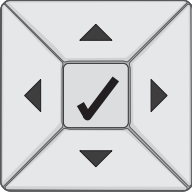
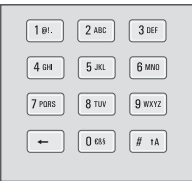
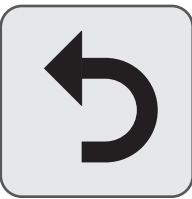

Control panel item		Description
3	Navigation buttons	 <p>Press the up or down arrow button to scroll through menu lists. Press the left or right arrow button to scroll through values or text that rolls to another screen.</p>
4	Numeric keypad	 <p>Consists of the numbers 0–9, characters A through Z, an ↑A, and a backspace button. Note: The ↑A button functions as Caps Lock, and includes the # character.</p>
5	Back	 <p>Returns the display to the previous screen</p>
6	Indicator light	<p>Indicates the printer status:</p> <ul style="list-style-type: none"> • Off—The power is off, or the printer is in Eco Mode. • Blinking green—The printer is warming up, processing data, or printing. • Solid green—The printer is on, but idle. • Solid red—Operator intervention is needed.
7	Stop	 <p>Stops all printer activity A list of options is offered once Stopped appears on the display.</p>
8	Menus	 <p>Opens the menu index Note: These menus are available only when the printer is in the Ready state.</p>
9	USB Direct port	<p>Insert a USB flash drive to send data to the printer. Insert a USB cable from a digital camera to print photos with a PictBridge-enabled digital camera.</p>

Additional printer setup

Installing internal options

 **CAUTION—SHOCK HAZARD:** If you are accessing the system board or installing optional hardware or memory devices sometime after setting up the printer, then turn the printer off, and unplug the power cord from the wall outlet before continuing. If you have any other devices attached to the printer, then turn them off as well, and unplug any cables going into the printer.

You can customize your printer connectivity and memory capacity by adding optional cards.

Available internal options

- Memory cards
 - Printer memory
 - Flash memory
 - Fonts
- Firmware cards
 - Bar Code
 - PrintCrypton™
- Printer hard disk
- Lexmark™ Internal Solutions Ports (ISP)
 - RS-232-C Serial ISP
 - Parallel 1284-B ISP
 - MarkNet™ N8150 802.11 b/g/n Wireless ISP
 - MarkNet N8130 10/100 Fiber ISP
 - MarkNet N8120 10/100/1000 Ethernet ISP

Accessing the system board to install internal options

⚠ CAUTION—SHOCK HAZARD: If you are accessing the system board or installing optional hardware or memory devices sometime after setting up the printer, then turn the printer off, and unplug the power cord from the wall outlet before continuing. If you have any other devices attached to the printer, then turn them off as well, and unplug any cables going into the printer.

Note: This operation requires a flathead screwdriver.

1 Remove the cover.

- a** Turn the screws on the cover counterclockwise to loosen them, but do not remove them.

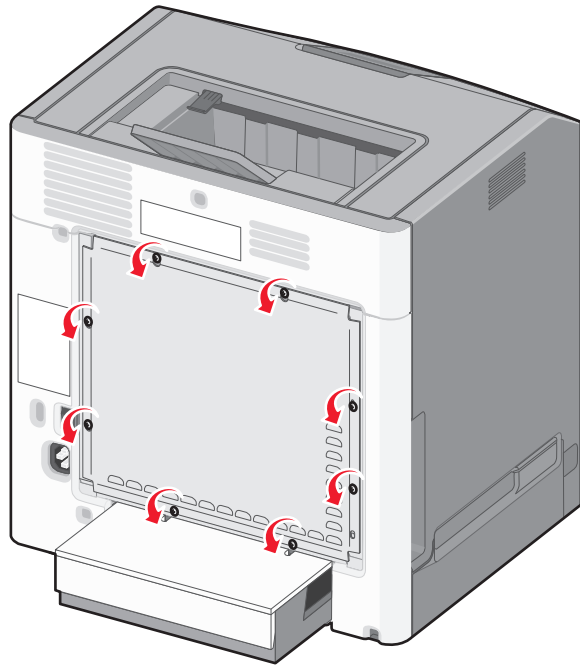

- b** Slide the cover up until each screw is in the keyhole.

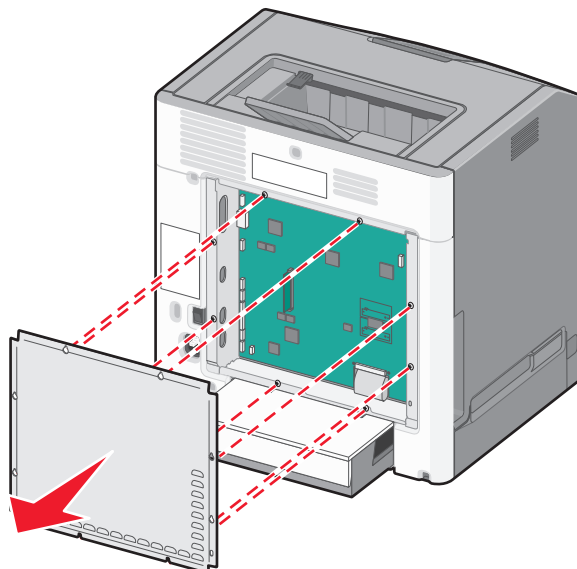

- c** Pull the cover forward to remove it.

2 Use the following illustration to locate the appropriate connector.

Warning—Potential Damage: System board electronic components are easily damaged by static electricity. Touch something metal on the printer before touching any system board electronic components or connectors.

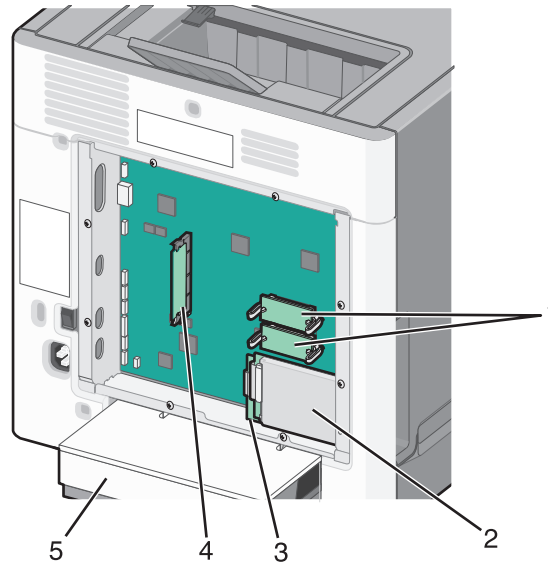

1	Firmware and flash memory card connectors
2	Hard disk connector
3	Internal print server connector
4	Memory card connector
5	Dust cover

Installing a memory card

CAUTION—SHOCK HAZARD: If you are accessing the system board or installing optional hardware or memory devices sometime after setting up the printer, then turn the printer off, and unplug the power cord from the wall outlet before continuing. If you have any other devices attached to the printer, then turn them off as well, and unplug any cables going into the printer.

Warning—Potential Damage: System board electronic components are easily damaged by static electricity. Touch something metal on the printer before touching any system board electronic components or connectors.

An optional memory card can be purchased separately and attached to the system board. To install the memory card:

- 1 Access the system board.
- 2 Unpack the memory card.

Note: Avoid touching the connection point along the edge of the card.

3 Open the memory card connector latches.



4 Align the notch on the memory card with the ridge on the connector.

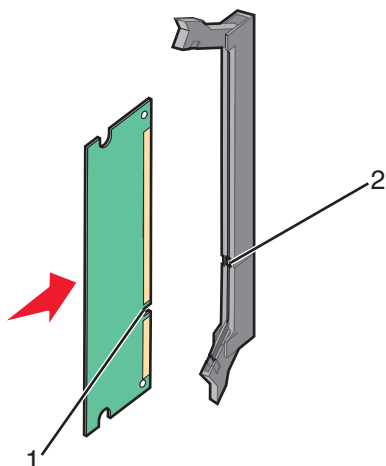

1	Notch
2	Ridge

- 5 Push the memory card straight into the connector until it *snaps* into place.

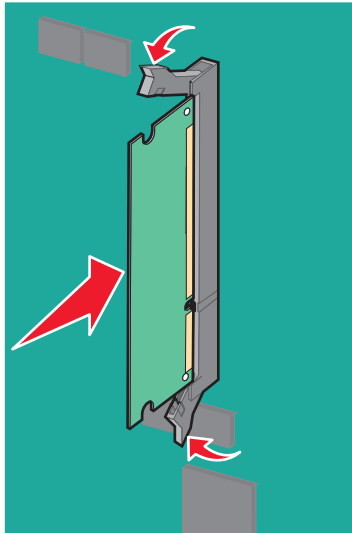

- 6 Reattach the system board cover.

Installing a flash memory or firmware card

The system board has two connections for an optional flash memory or firmware card. Only one of each may be installed, but the connectors are interchangeable.

⚠ CAUTION—SHOCK HAZARD: If you are accessing the system board or installing optional hardware or memory devices sometime after setting up the printer, then turn the printer off, and unplug the power cord from the wall outlet before continuing. If you have any other devices attached to the printer, then turn them off as well, and unplug any cables going into the printer.

Warning—Potential Damage: System board electronic components are easily damaged by static electricity. Touch something metal on the printer before touching any system board electronic components or connectors.

- 1 Access the system board.
- 2 Unpack the card.

Note: Avoid touching the connection points along the edge of the card.

3 Holding the card by its sides, align the plastic pins on the card with the holes on the system board.

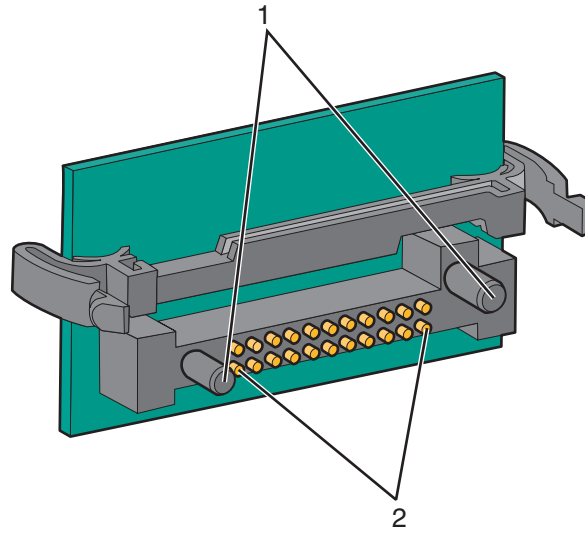

1	Plastic pins
2	Metal pins

4 Push the card firmly into place.

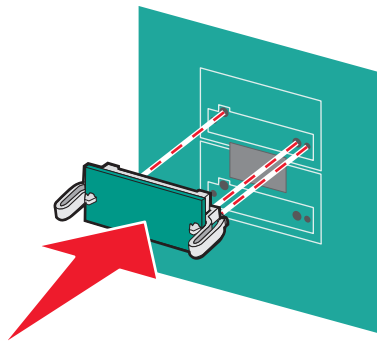

Notes:

- The entire length of the connector on the card must touch and be flush against the system board.
- Be careful not to damage the connectors.

5 Reattach the system board cover.

Installing an Internal Solutions Port

The system board supports one optional Lexmark Internal Solutions Port (ISP).

Note: This task requires a flathead screwdriver.

CAUTION—SHOCK HAZARD: If you are accessing the system board or installing optional hardware or memory devices sometime after setting up the printer, then turn the printer off, and unplug the power cord from the wall outlet before continuing. If you have any other devices attached to the printer, then turn them off as well, and unplug any cables going into the printer.

Warning—Potential Damage: System board electronic components are easily damaged by static electricity. Touch something metal on the printer before touching any system board electronic components or connectors.

- 1 Access the system board.
- 2 Unpack the ISP and plastic tee.
Note: Avoid touching the components on the card.
- 3 Locate the appropriate connector on the system board.

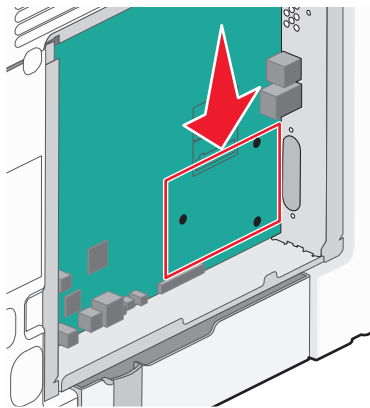

Note: If an optional printer hard disk is currently installed, then it must first be removed. To remove the printer hard disk:

- a** Unplug the printer hard disk interface cable from the system board, leaving the cable attached to the printer hard disk. To unplug the cable, squeeze the paddle at the plug of the interface cable to disengage the latch before pulling the cable out.

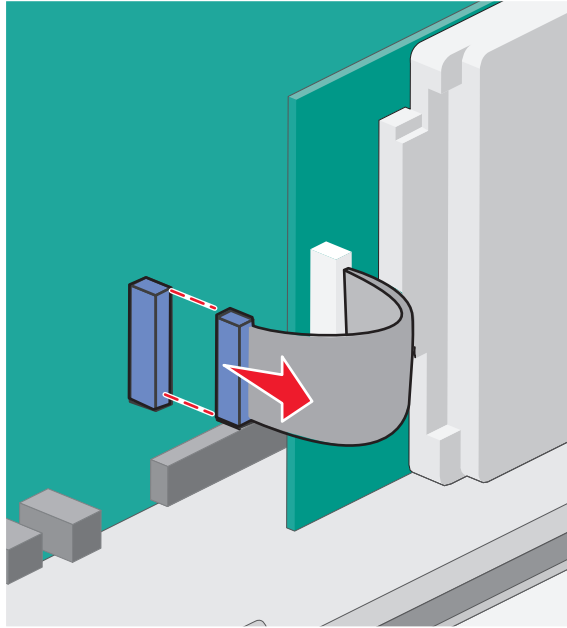

- b** Remove the screws holding the printer hard disk in place.

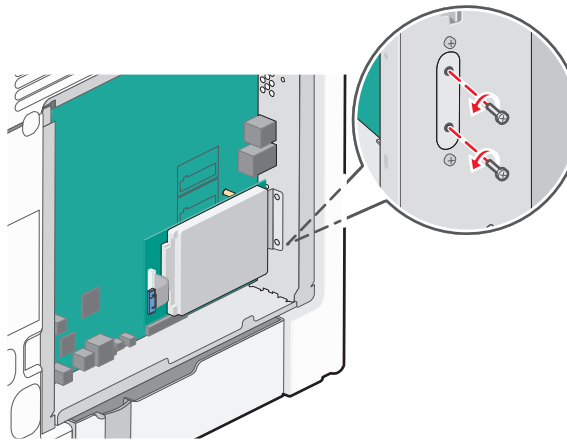

- c Remove the printer hard disk by pulling it upward to unseat the standoffs.

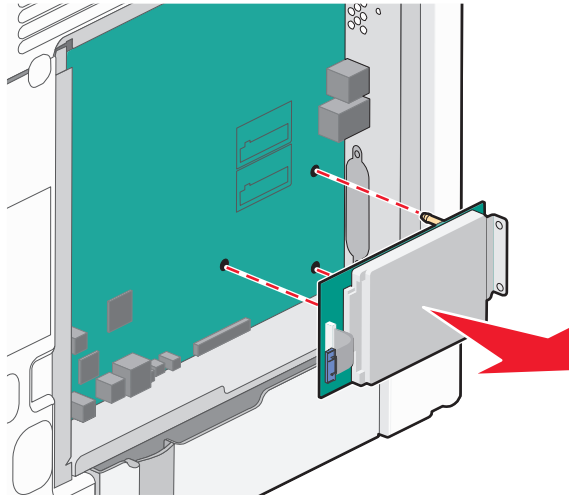

- d Remove the thumbscrews that attach the printer hard disk mounting bracket to the printer hard disk, and then remove the bracket. Set the printer hard disk aside.

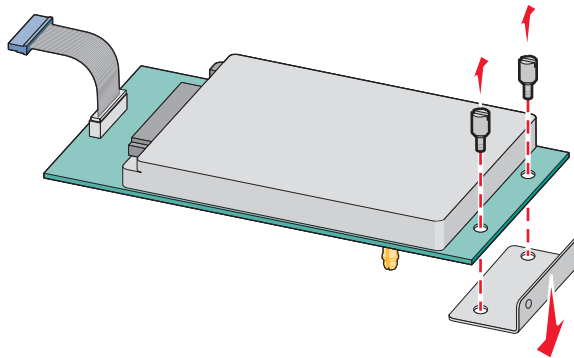

- 4 Remove the metal cover from the ISP opening.

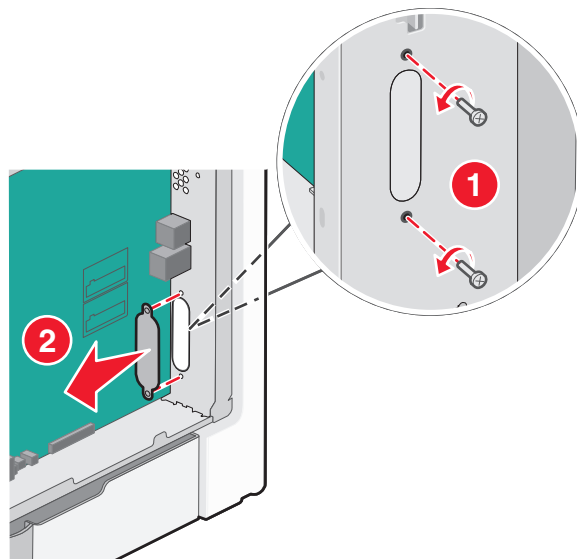

- 5 Align the posts of the plastic tee to the holes in the system board, and press downward until the tee *snaps* into place. Be sure each post of the tee has latched completely, and the tee is seated firmly on the system board.

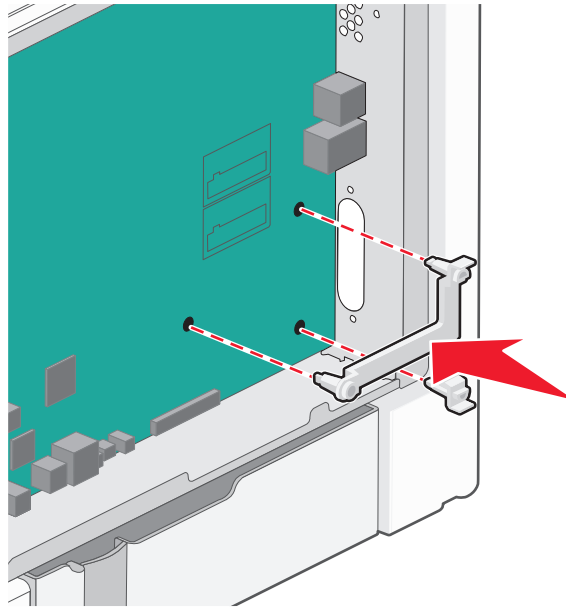

- 6 Install the ISP on the plastic tee. Angle the ISP over the plastic tee, and approach the plastic tee so that any overhanging connectors will pass through the ISP opening in the system board cage.

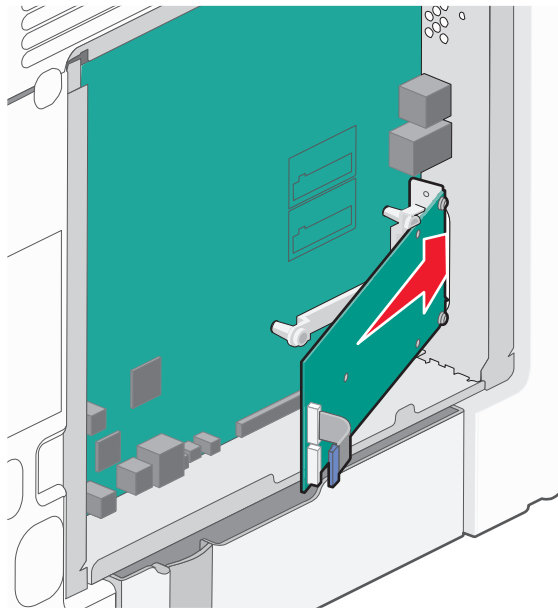

- 7** Lower the ISP toward the plastic tee until the ISP is seated between the guides of the plastic tee.

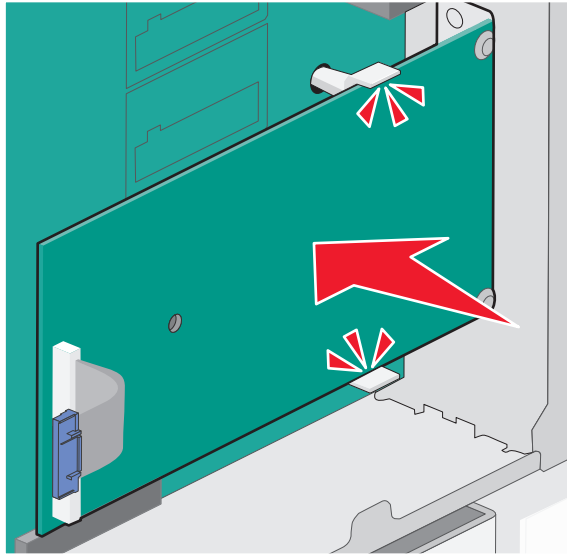

- 8** Insert the long thumbscrew and turn it clockwise enough to hold the ISP in place, but do not tighten the thumbscrew at this time.

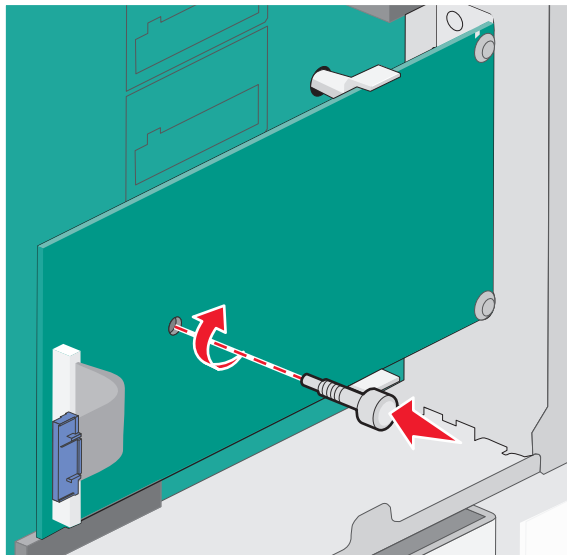

- 9 Attach the two provided screws to secure the ISP mounting bracket to the system board cage.

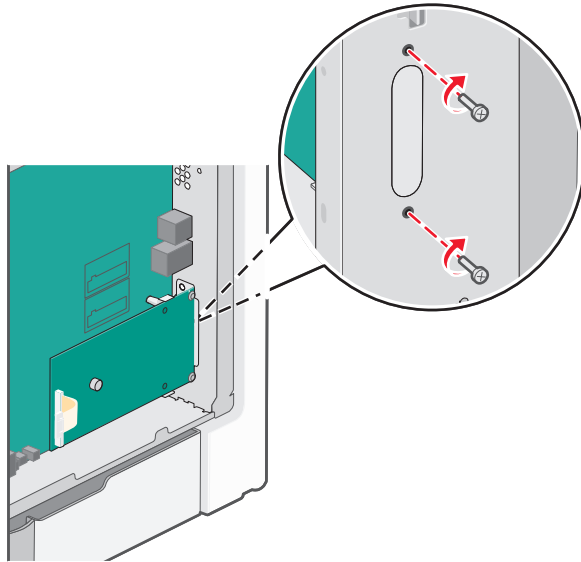

- 10 Tighten the long thumbscrew.

Warning—Potential Damage: Do not overtighten the thumbscrew.

- 11 Insert the plug of the ISP interface cable into the receptacle of the system board.

Note: The plugs and receptacles are color-coded.

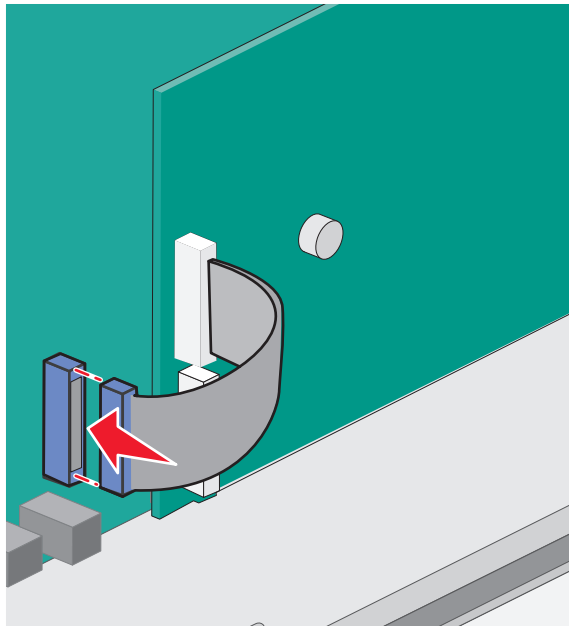

- 12 Reattach the system board cover.

Installing a printer hard disk

The optional printer hard disk can be installed with or without a Lexmark Internal Solutions Port (ISP).

Note: This task requires a flathead screwdriver.

CAUTION—SHOCK HAZARD: If you are accessing the system board or installing optional hardware or memory devices sometime after setting up the printer, then turn the printer off, and unplug the power cord from the wall outlet before continuing. If you have any other devices attached to the printer, then turn them off as well, and unplug any cables going into the printer.

Warning—Potential Damage: System board electronic components are easily damaged by static electricity. Touch something metal on the printer before touching any system board electronic components or connectors.

- 1 Access the system board.
- 2 Unpack the printer hard disk.
Note: Avoid touching the components on the card.
- 3 Locate the appropriate connector on the system board.

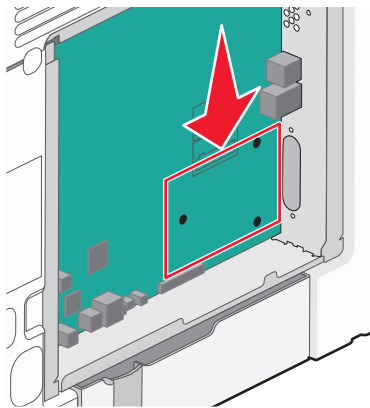

Note: If an optional ISP is currently installed, then the printer hard disk must be installed onto the ISP.

To install a printer hard disk onto the ISP:

- a Using a flathead screwdriver to loosen the screws, remove the thumbscrews that attach the printer hard disk mounting bracket to the printer hard disk, and then remove the bracket.

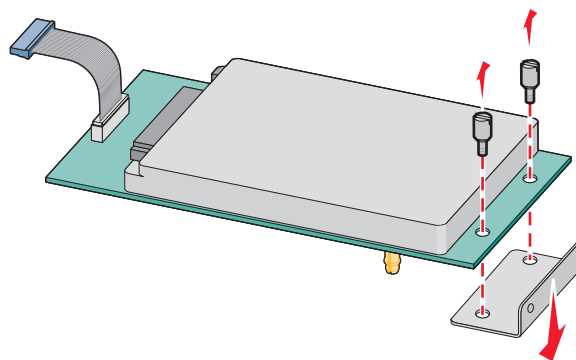

- b** Align the standoffs of the printer hard disk with the holes in the ISP, and then press downward on the printer hard disk until the standoffs have seated into place.

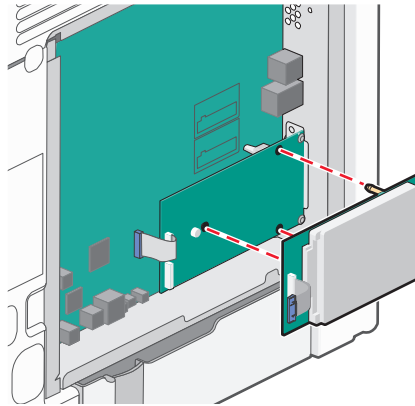

- c** Insert the plug of the printer hard disk interface cable into the receptacle of the ISP.

Note: The plugs and receptacles are color-coded.

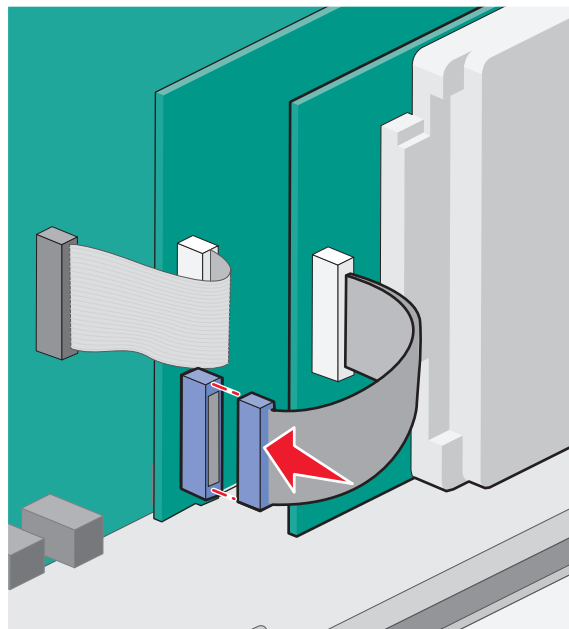

To install a printer hard disk directly on the system board:

- a Align the standoffs of the printer hard disk with the holes in the system board, and then press downward on the printer hard disk until the standoffs have seated into place.

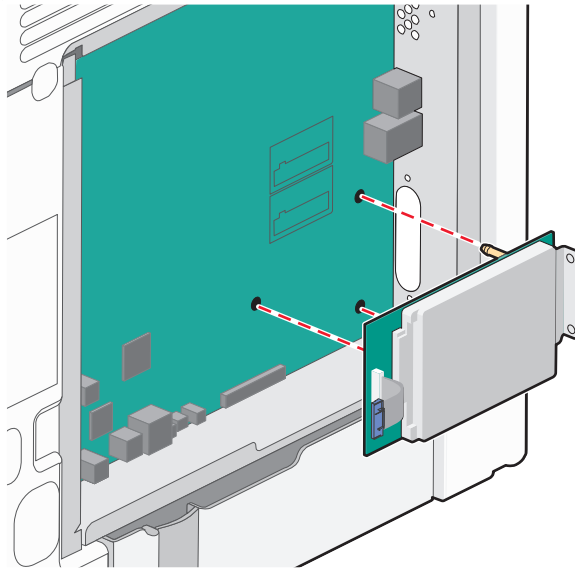

- b Attach the two provided screws to secure the printer hard disk mounting bracket.

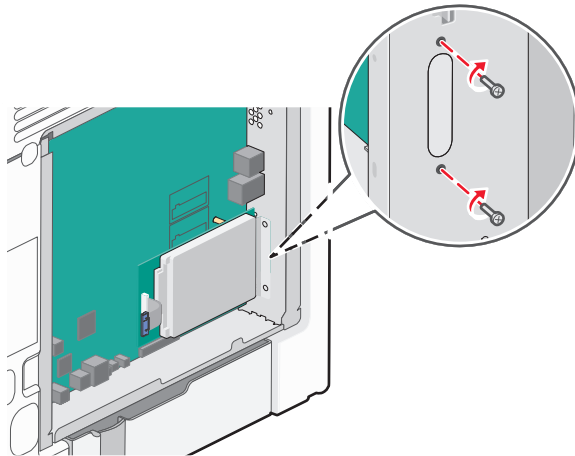

- c Insert the plug of the printer hard disk interface cable into the receptacle of the system board.

Note: The plugs and receptacles are color-coded.

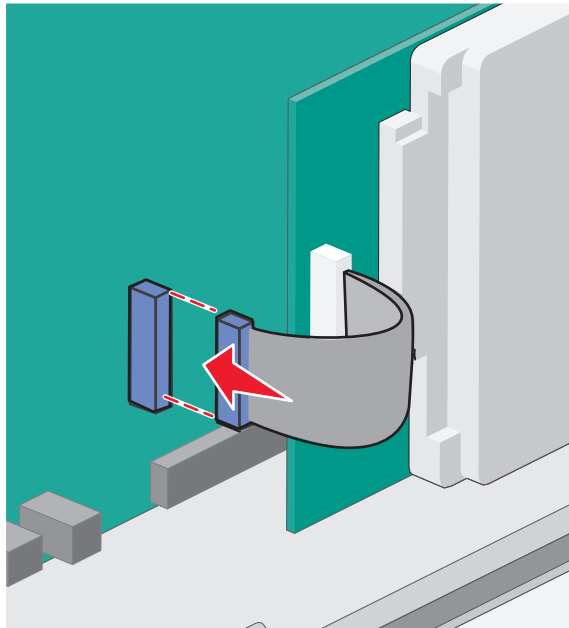

4 Reattach the system board cover.

Reattaching the system board cover

Warning—Potential Damage: System board electrical components are easily damaged by static electricity. Touch something metal on the printer before touching any system board electronic components or connectors.

Note: This task requires a flathead screwdriver.

1 Align the eight keyholes with the screws to replace the cover.

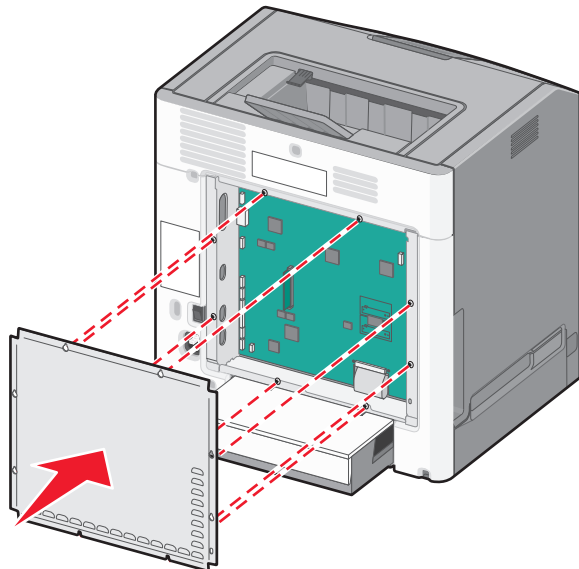

- Slide the cover down, and then turn each screw clockwise to tighten.

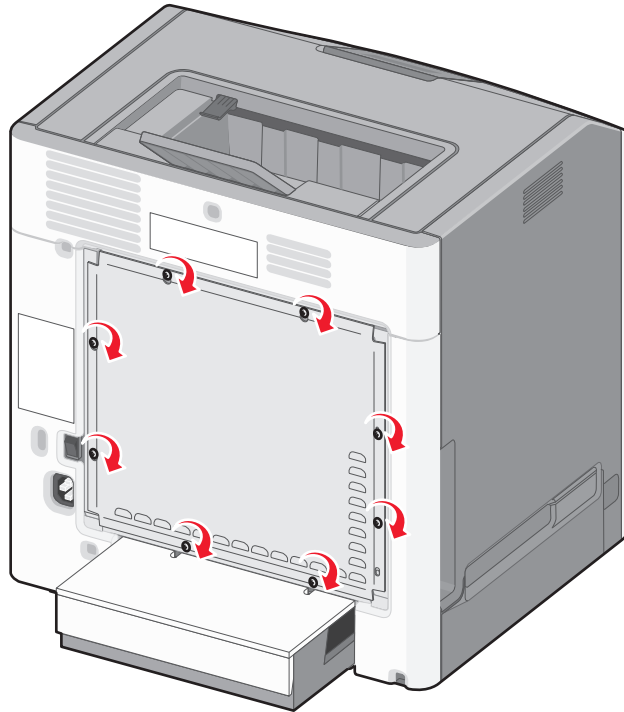

Installing hardware options

Installing optional trays

The printer supports three types of optional input sources: an optional 550-sheet tray, an optional 2,000-sheet tray, and an optional 550-sheet specialty media drawer. Instructions for installing an optional input source are the same for each.

CAUTION—TIPPING HAZARD: Floor-mounted configurations require additional furniture for stability. You must use either a printer stand or printer base if you are using a high-capacity input tray, a duplex unit and an input option, or more than one input option. If you purchased a multifunction printer (MFP) that scans, copies, and faxes, you may need additional furniture. For more information, see www.lexmark.com/multifunctionprinters.

Note: The C736n, C736dn, and C736dtn model printers support a total of four optional input sources. The C734n, C734dn, C734dtn, and C734dnw model printers support a total of three optional input sources.

CAUTION—POTENTIAL INJURY: The printer weight is greater than 18 kg (40 lb) and requires two or more trained personnel to lift it safely.

CAUTION—SHOCK HAZARD: If you are accessing the system board or installing optional hardware or memory devices sometime after setting up the printer, then turn the printer off, and unplug the power cord from the wall outlet before continuing. If you have any other devices attached to the printer, then turn them off as well, and unplug any cables going into the printer.

- 1 Unpack the optional tray, and remove all packing material.
- 2 Place the tray in the location chosen for the printer.

Note: If you are installing more than one optional tray, the 2,000-sheet tray must always be installed first (configuring from the bottom up).

Warning—Potential Damage: The optional 550-sheet tray and the optional 550-sheet specialty media drawer are not interchangeable.

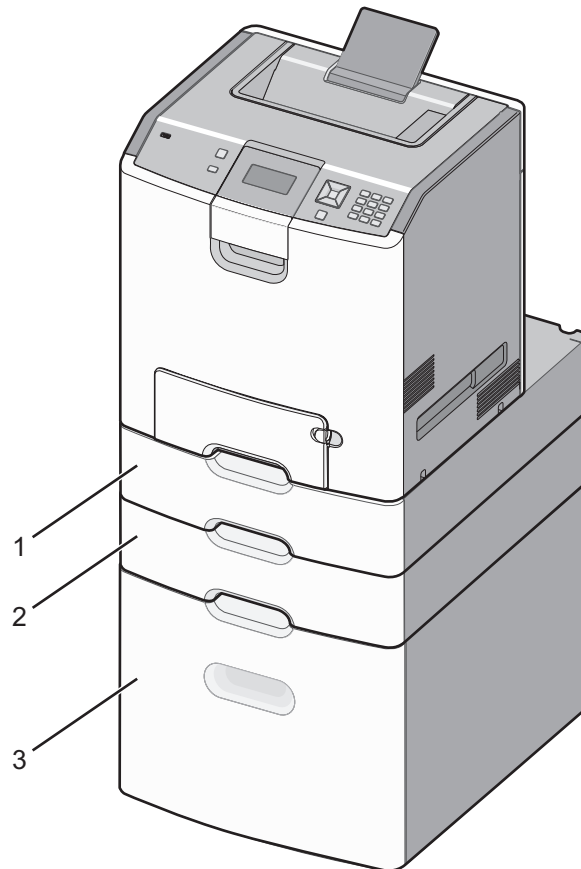

1	Optional 550-sheet specialty media drawer
2	Optional 550-sheet tray
3	Optional 2,000-sheet tray

Note: Optional trays lock together when stacked. Remove stacked trays one at a time from the top down.

- 3 Align the printer with the tray, and then lower the printer into place.

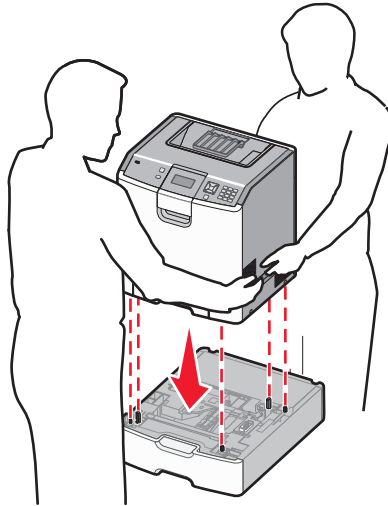

- 4 Label the trays and drawers with the supplied number labels from the top down.

Note: The standard 550-sheet tray (Tray 1) must be labeled as the first tray.

Attaching cables

⚠ CAUTION—POTENTIAL INJURY: Do not use the fax feature during a lightning storm. Do not set up this product or make any electrical or cabling connections, such as the fax feature, power cord, or telephone, during a lightning storm.

Connect the printer to the computer using a USB cable or Ethernet cable.

Be sure to match the following:

- The USB symbol on the cable with the USB symbol on the printer
- The appropriate Ethernet cable to the Ethernet port

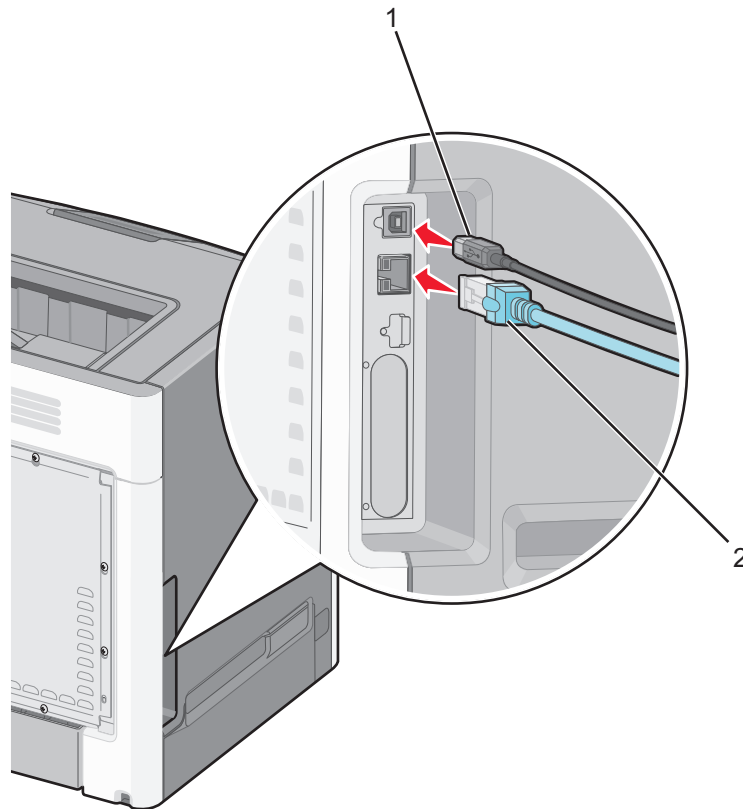



1	USB port Warning—Potential Damage: Do not touch the USB cable, any network adapter, or the printer in the area shown while actively printing. A loss of data or a malfunction can occur.
2	Ethernet port

Verifying printer setup

Printing a menu settings page

Print a menu settings page to review the current menu settings and to verify if the printer options are installed correctly.



Note: If you have not made any menu item settings changes yet, then the menu settings page lists all the factory default settings. Once you select and save other settings from the menus, they replace the factory default settings as *user default settings*. A user default setting remains in effect until you access the menu again, choose another value, and save it.

- 1** Make sure the printer is on and **Ready** appears.
- 2** From the printer control panel, press .
- 3** Press the up or down arrow button until **✓Reports** appears, and then press .
- 4** Press the up or down arrow button until **✓Menu Settings Page** appears, and then press .

After the menu settings page prints, the printer returns to the **Ready** state.

Printing a network setup page

If the printer is attached to a network, then print a network setup page to verify the network connection. This page also provides important information that aids network printing configuration.

- 1 Make sure the printer is on and **Ready** appears.
- 2 From the printer control panel, press .
- 3 Press the up or down arrow button until **√Reports** appears, and then press .
- 4 Press the up or down arrow button until **√Network Setup Page** appears, and then press .

Note: If an optional internal print server is installed, **Print Network <x> Setup Page** appears.

- 5 Check the first section on the network setup page, and confirm that Status is “Connected.”
If Status is “Not Connected,” the LAN drop may not be active, or the network cable may be malfunctioning. Consult a system support person for a solution, and then print another network setup page.

Setting up the printer software

Installing printer software

A printer driver is software that lets the computer communicate with the printer. The printer software is typically installed during the initial printer setup.

For Windows users

- 1 Close all open software programs.
- 2 Insert the *Software and Documentation* CD.
- 3 From the main installation dialog, click **Install Printer and Software**.
- 4 Follow the instructions on the computer screen.

For Macintosh users

- 1 Close all open software applications.
- 2 Insert the *Software and Documentation* CD.
- 3 From the Finder desktop, double-click the printer CD icon that automatically appears.
- 4 Double-click the **Install Printer and Software** icon.
- 5 Follow the instructions on the computer screen.

Using the World Wide Web

- 1 Go to the Lexmark Web site at **www.lexmark.com**.
- 2 From the Drivers & Downloads menu, click **Driver Finder**.
- 3 Select your printer, and then select your operating system.
- 4 Download the driver and install the printer software.

Updating available options in the printer driver

Once the printer software and any options are installed, it may be necessary to manually add the options in the printer driver to make them available for print jobs.

For Windows users

- 1 Open the Printers folder:
 - a Click , or click **Start** and then click **Run**.
 - b In the Start Search or Run box, type **control printers**.
 - c Press **Enter**, or click **OK**.
The printer folder opens.
- 2 Select the printer.
- 3 Right-click the printer, and then select **Properties**.
- 4 Click the Install Options tab.
- 5 Under Available Options, add any installed hardware options.
- 6 Click **Apply**.

For Macintosh users

In Mac OS X version 10.5 or later

- 1 From the Apple menu, choose **System Preferences**.
- 2 Click **Print & Fax**.
- 3 Select the printer, and then click **Options & Supplies**.
- 4 Click **Driver**, and then add any installed hardware options.
- 5 Click **OK**.

In Mac OS X version 10.4 and earlier

- 1 From the Finder desktop, choose **Go > Applications**.
- 2 Double-click **Utilities**, and then double-click **Print Center** or **Printer Setup Utility**.
- 3 Select the printer, and then from the Printers menu, choose **Show Info**.
- 4 From the pop-up menu, choose **Installable Options**.
- 5 Add any installed hardware options, and then click **Apply Changes**.

Setting up wireless printing

Note: A Service Set Identifier (SSID) is a name assigned to a wireless network. Wireless Encryption Protocol (WEP) and Wi-Fi Protected Access (WPA) are types of security used on a network.

Information you will need to set up the printer on a wireless network

Note: Do not connect the installation or network cables until prompted to do so by the setup software.

- **SSID**—The SSID is also referred to as the network name.
- **Wireless Mode (or Network Mode)**—The mode will be either infrastructure or ad hoc.
- **Channel (for ad hoc networks)**—The channel defaults to auto for infrastructure networks.
Some ad hoc networks will also require the auto setting. Check with your system support person if you are not sure which channel to select.
- **Security Method**—There are three basic options for Security Method:
 - WEP key
If your network uses more than one WEP key, enter up to four in the provided spaces. Select the key currently in use on the network by selecting the Default WEP Transmit Key.
or
 - WPA or WPA2 passphrase
WPA includes encryption as an additional layer of security. The choices are AES or TKIP. Encryption must be set for the same type on the router and on the printer, or the printer will not be able to communicate on the network.
 - No security
If your wireless network does not use any type of security, then you will not have any security information.

Note: Using an unsecured wireless network is not recommended.

If you are installing the printer on an 802.1X network using the Advanced method, then you may need the following:

- Authentication type
- Inner authentication type
- 802.1X username and password
- Certificates

Note: For more information on configuring 802.1X security, see the *Networking Guide* on the *Software and Documentation* CD.

Installing the printer on a wireless network (Windows)

Before you install the printer on a wireless network, make sure that:

- Your wireless network is set up and working properly.
- The computer you are using is connected to the same wireless network where you want to set up the printer.

1 Connect the power cable to the printer and then to a properly grounded electrical outlet, and then turn the printer on.

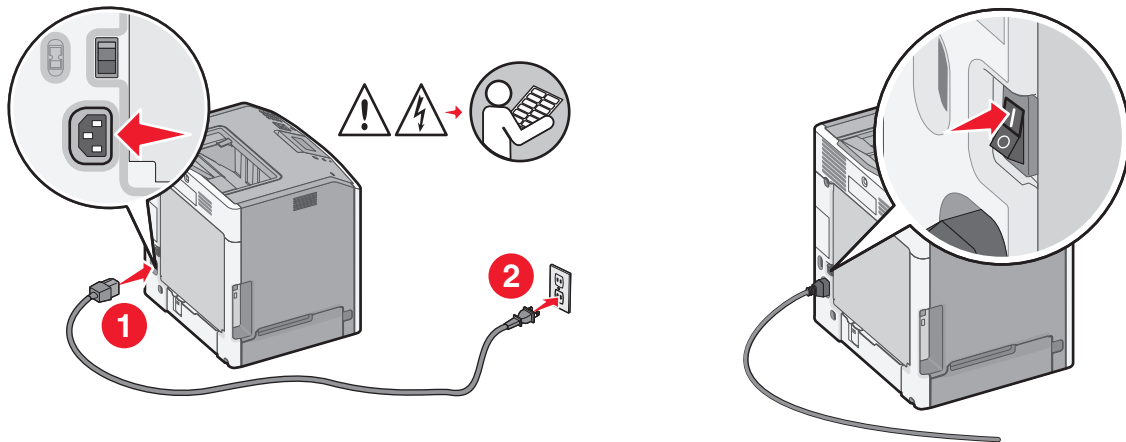

Make sure the printer and computer are fully on and ready.



Do not connect the USB cable until instructed to do so on the screen.

2 Insert the *Software and Documentation* CD.

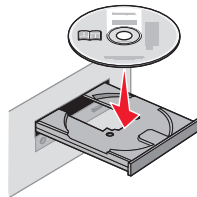

3 Click **Install Printer and Software**.

4 Click **Agree** to agree to the License Agreement.

5 Click **Suggested**, and then click **Next**.

6 Click **Wireless Network Attach**.

- 7 Temporarily connect a USB cable between the computer on the wireless network and the printer.

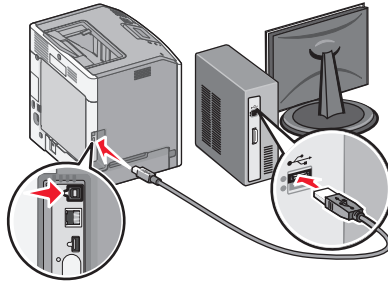

Note: After the printer is configured, the software will instruct you to disconnect the temporary USB cable so you can print wirelessly.

- 8 Follow the instructions on the computer screen to complete the software installation.

Note: **Basic** is the recommended path to choose. Choose **Advanced** only if you want to customize your installation.

- 9 To allow other computers on the wireless network to use the wireless printer, follow steps 2 through 6 and step 8 for each computer.

Installing the printer on a wireless network (Macintosh)

Prepare to configure the printer

- 1 Locate the printer MAC address on the sheet that came with the printer. Write the last six digits of the MAC address in the space provided below:

MAC address: _____

- 2 Connect the power cable to the printer and then to a properly grounded electrical outlet, and then turn the printer on.

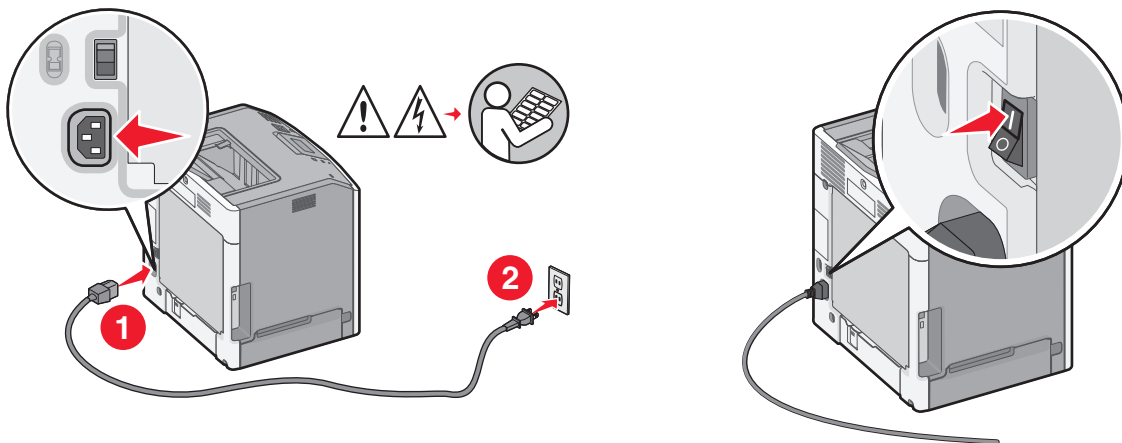

Enter the printer information

- 1 Access the AirPort options.

In Mac OS X version 10.5 or later

- a** From the Apple menu, choose **System Preferences**.
- b** Click **Network**.
- c** Click **AirPort**.

In Mac OS X version 10.4 and earlier

- a** From the Finder desktop, choose **Go > Applications**.
- b** From the Applications folder, double-click **Internet Connect**.
- c** From the toolbar, click **AirPort**.

- 2** From the Network pop-up menu, select **print server xxxxxx**, where the x's are the last six digits of the MAC address located on the MAC address sheet.
- 3** Open the Safari browser.
- 4** From the Bookmarks drop-down menu, select **Show**.
- 5** Under Collections, select **Bonjour** or **Rendezvous**, and then double-click the printer name.

Note: The application is referred to as *Rendezvous* in Mac OS X version 10.3, but is now called *Bonjour* by Apple Computer.

- 6** From the main page of the Embedded Web Server, navigate to the page where the wireless settings information is stored.

Configure the printer for wireless access

- 1** Type the name of your network (SSID) in the appropriate field.
- 2** Select **Infrastructure** as your Network Mode if you are using a wireless router.
- 3** Select the type of security you use to protect your wireless network.
- 4** Enter the security information necessary for the printer to join your wireless network.
- 5** Click **Submit**.
- 6** Open the AirPort application on your computer:

In Mac OS X version 10.5 or later

- a** From the Apple menu, choose **System Preferences**.
- b** Click **Network**.
- c** Click **AirPort**.

In Mac OS X version 10.4 and earlier

- a** From the Finder desktop, choose **Go > Applications**.
- b** From the Applications folder, double-click **Internet Connect**.
- c** From the toolbar, click **AirPort**.

- 7** From the Network pop-up menu, select your wireless network.

Configure your computer to use the printer wirelessly

To print to a network printer, each Macintosh user must install a custom *PostScript Printer Description* (PPD) file and create a printer in the Printer Setup Utility or Print Center.

1 Install a PPD file on the computer:

- a Insert the *Software and Documentation* CD in the CD or DVD drive.
- b Double-click the installer package for the printer.
- c From the Welcome screen, click **Continue**.
- d Click **Continue** again after viewing the Readme file.
- e Click **Continue** after viewing the license agreement, and then click **Agree** to accept the terms of the agreement.
- f Select a Destination, and then click **Continue**.
- g From the Easy Install screen, click **Install**.
- h Type the user password, and then click **OK**.
All necessary software is installed on the computer.
- i Click **Close** when installation is complete.

2 Add the printer:

a For IP printing:

In Mac OS X version 10.5 or later

- 1 From the Apple menu, choose **System Preferences**.
- 2 Click **Print & Fax**.
- 3 Click **+**.
- 4 Select the printer from the list.
- 5 Click **Add**.

In Mac OS X version 10.4 and earlier

- 1 From the Finder desktop, choose **Go > Applications**.
- 2 Double-click the **Utilities** folder.
- 3 Locate and double-click **Printer Setup Utility** or **Print Center**.
- 4 From the Printer List, choose **Add**.
- 5 Select the printer from the list.
- 6 Click **Add**.

b For AppleTalk printing:

In Mac OS X version 10.5

- 1 From the Apple menu, choose **System Preferences**.
- 2 Click **Print & Fax**.
- 3 Click **+**.
- 4 Click **AppleTalk**.
- 5 Select the printer from the list.
- 6 Click **Add**.

In Mac OS X version 10.4 and earlier

- 1 From the Finder desktop, choose **Go > Applications**.
- 2 Double-click the **Utilities** folder.

- 3 Locate and double-click **Printer Setup Utility** or **Print Center**.
- 4 From the Printer List, choose **Add**.
- 5 Choose the **Default Browser** tab.
- 6 Click **More Printers**.
- 7 From the first pop-up menu, choose **AppleTalk**.
- 8 From the second pop-up menu, select **Local AppleTalk zone**.
- 9 Select the printer from the list.
- 10 Click **Add**.

Installing the printer on a wired network

These instructions apply to Ethernet and fiber optic network connections.

Before you install the printer on a wired network, make sure that:

- You have completed the initial setup of the printer.
- The printer is connected to your network with the appropriate type of cable.

For Windows users

- 1 Insert the *Software and Documentation* CD.

Wait for the Welcome screen to appear.

If the CD does not launch after a minute, then do the following:

- a Click , or click **Start** and then click **Run**.
- b In the Start Search or Run box, type **D:\setup.exe**, where **D** is the letter of your CD or DVD drive.

- 2 Click **Install Printer and Software**.
- 3 Click **Agree** to agree to the License Agreement.
- 4 Select **Suggested**, and then click **Next**.

Note: To configure the printer using a static IP address, using IPv6, or to configure printers using scripts, select **Custom** and follow the instructions on the computer screen.

- 5 Select **Wired Network Attach**, and then click **Next**.
- 6 Select the printer manufacturer from the list.
- 7 Select the printer model from the list, and then click **Next**.
- 8 Select the printer from the list of printers discovered on the network, and then click **Finish**.

Note: If your configured printer does not appear in the list of discovered printers, click **Add Port** and follow the instructions on the computer screen.

- 9 Follow the instructions on the computer screen to complete the installation.

For Macintosh users

- 1 Allow the network DHCP server to assign an IP address to the printer.
- 2 Print the network setup page from the printer. For information on printing a network setup page, see “Printing a network setup page” on page 34.

3 Locate the printer IP address in the TCP/IP section of the network setup page. You will need the IP address if you are configuring access for computers on a different subnet than the printer.

4 Install the drivers and add the printer.

a Install a PPD file on the computer:

- 1** Insert the *Software and Documentation* CD in the CD or DVD drive.
- 2** Double-click the installer package for the printer.
- 3** From the Welcome screen, click **Continue**.
- 4** Click **Continue** again after viewing the Readme file.
- 5** Click **Continue** after viewing the license agreement, and then click **Agree** to accept the terms of the agreement.
- 6** Select a Destination, and then click **Continue**.
- 7** From the Easy Install screen, click **Install**.
- 8** Type the user password, and then click **OK**.
All the necessary software is installed on the computer.
- 9** Click **Restart** when installation is complete.

b Add the printer:

- For IP printing:

In Mac OS X version 10.5 or later

- 1** From the Apple menu, choose **System Preferences**.
- 2** Click **Print & Fax**.
- 3** Click **+**.
- 4** Click **IP**.
- 5** Type the IP address of your printer in the Address field.
- 6** Click **Add**.

In Mac OS X version 10.4 and earlier

- 1** From the Finder desktop, choose **Go > Applications**.
- 2** Double-click **Utilities**.
- 3** Double-click **Printer Setup Utility** or **Print Center**.
- 4** From the Printer List, click **Add**.
- 5** Click **IP**.
- 6** Type the IP address of your printer in the Address field.
- 7** Click **Add**.

- For AppleTalk printing:

In Mac OS X version 10.5

- 1** From the Apple menu, choose **System Preferences**.
- 2** Click **Print & Fax**.
- 3** Click **+**.
- 4** Click **AppleTalk**.
- 5** Select the printer from the list.
- 6** Click **Add**.

In Mac OS X version 10.4 and earlier

- 1 From the Finder desktop, choose **Go > Applications**.
- 2 Double-click **Utilities**.
- 3 Double-click **Printer Setup Utility** or **Print Center**.
- 4 From the Printer List, click **Add**.
- 5 Choose the **Default Browser** tab.
- 6 Click **More Printers**.
- 7 From the first pop-up menu, choose **AppleTalk**.
- 8 From the second pop-up menu, select **Local AppleTalk zone**.
- 9 Select the printer from the list.
- 10 Click **Add**.

Note: If the printer doesn't show up in the list, you may need to add it using the IP address. Contact your system support person for assistance.

Changing port settings after installing a new network Internal Solutions Port

When a new network Lexmark Internal Solutions Port (ISP) is installed in the printer, the printer is assigned a new IP address. The printer configurations on computers that access the printer must be updated with this new IP address in order to print to it over the network.

Notes:

- If the printer has a static IP address that will stay the same, then you do not need to make any changes to the computer configurations.
- If the computers are configured to print to the printer by a network name that will stay the same, instead of by IP address, then you do not need to make any changes to the computer configurations.
- If you are adding a wireless ISP to a printer previously configured for a wired connection, then make sure the wired network is disconnected when you configure the printer to operate wirelessly. If the wired connection remains connected, then the wireless configuration will complete, but the wireless ISP will not be active. In the event that the printer was configured for a wireless ISP while still attached to a wired connection, disconnect the wired connection, turn the printer off, and then turn the printer back on again. This will enable the wireless ISP.
- Only one network connection at a time is active. If you want to switch the connection type between wired and wireless, you must first turn the printer off, connect the cable (to switch to a wired connection) or disconnect the cable (to switch to a wireless connection), and then turn the printer back on again.

For Windows users

- 1 Print a network setup page and make a note of the new IP address.
- 2 Open the printers folder:
 - a Click , or click **Start** and then click **Run**.
 - b In the Start Search or Run box, type **control printers**.
 - c Press **Enter**, or click **OK**.
The printers folder opens.

- 3 Locate the printer that has changed.
Note: If there is more than one copy of the printer, then update all of them with the new IP address.
- 4 Right-click the printer.
- 5 Click **Properties**.
- 6 Click the **Ports** tab.
- 7 Locate the port in the list, and then select it.
- 8 Click **Configure Port**.
- 9 Type the new IP address in the “Printer Name or IP Address” field. You can find the new IP address on the network setup page you printed in step 1.
- 10 Click **OK**, and then click **Close**.

For Macintosh users

- 1 Print a network setup page and make a note of the new IP address.
- 2 Locate the printer IP address in the TCP/IP section of the network setup page. You will need the IP address if you are configuring access for computers on a different subnet than the printer.
- 3 Add the printer:
 - For IP printing:

In Mac OS X version 10.5 or later

- a From the Apple menu, choose **System Preferences**.
- b Click **Print & Fax**.
- c Click **+**.
- d Click **IP**.
- e Type the IP address of your printer in the Address field.
- f Click **Add**.

In Mac OS X version 10.4 and earlier

- a From the Go menu, choose **Applications**.
- b Double-click **Utilities**.
- c Double-click **Printer Setup Utility** or **Print Center**.
- d From the Printer List, click **Add**.
- e Click **IP**.
- f Type the IP address of your printer in the Address field.
- g Click **Add**.

- For AppleTalk printing:

In Mac OS X version 10.5

- a From the Apple menu, choose **System Preferences**.
- b Click **Print & Fax**.
- c Click **+**.
- d Click **AppleTalk**.

- e Select the printer from the list.
- f Click **Add**.

In Mac OS X version 10.4 and earlier

- a From the Go menu, choose **Applications**.
- b Double-click **Utilities**.
- c Double-click **Printer Setup Utility** or **Print Center**.
- d From the Printer List, click **Add**.
- e Choose the **Default Browser** tab.
- f Click **More Printers**.
- g From the first pop-up menu, choose **AppleTalk**.
- h From the second pop-up menu, select **Local AppleTalk zone**.
- i Select the printer from the list.
- j Click **Add**.

Setting up serial printing

In serial printing, data is transferred one bit at a time. Although serial printing is usually slower than parallel printing, it is the preferred option when there is a great deal of distance between the printer and computer or when an interface with a better transfer rate is not available.

After installing the serial or communication (COM) port, you will need to configure the printer and the computer so they can communicate. Make sure you have connected the serial cable to the COM port on your printer.

1 Set the parameters in the printer:

- a From the printer control panel, navigate to the menu with port settings.
- b Locate the submenu with serial port settings.
- c Make any necessary changes to the serial settings.
- d Save the new settings.
- e Print a menu settings page.

2 Install the printer driver:

- a Insert the *Software and Documentation* CD. It launches automatically.
If the CD does not launch automatically, then do the following:
 - 1 Click , or click **Start** and then click **Run**.
 - 2 In the Start Search or Run box, type **D:\setup.exe**, where **D** is the letter of your CD or DVD drive.
- b Click **Install Printer and Software**.
- c Click **Agree** to accept the Printer Software License Agreement.
- d Click **Custom**.
- e Make sure **Select Components** is selected, and then click **Next**.
- f Select the printer model from the menu, and then click **Add Printer**.
- g Click the **+** beside the printer model under **Select Components**.
- h Make sure the correct COM port is available under **Select Components**. This is the port where the serial cable attaches to the computer (example: COM1).

- i** Make sure the box next to the selected printer model is checked.
- j** Select any other optional software you want to install, and then click **Next**.
- k** Click **Finish** to complete the printer software installation.

3 Set the COM port parameters:

After the printer driver is installed, you must set the serial parameters in the COM port assigned to the printer driver.

The serial parameters in the COM port must match the serial parameters you set in the printer.

- a** Open the Device Manager.
 - 1** Click , or click **Start** and then click **Run**.
 - 2** In the Start Search or Run box, type `devmgmt.msc`.
 - 3** Press **Enter**, or click **OK**.
The Device Manager opens.
- b** Click **+** to expand the list of available ports.
- c** Select the communications port where you attached the serial cable to your computer (example: COM1).
- d** Click **Properties**.
- e** On the Port Settings tab, set the serial parameters to the same serial parameters in the printer.
Look for the printer settings under the serial heading on the menu settings page you printed earlier.
- f** Click **OK**, and then close all the windows.
- g** Print a test page to verify printer installation. When a test page prints successfully, printer setup is complete.

Minimizing your printer's environmental impact

Lexmark is committed to environmental sustainability and is continually improving its printers to reduce their impact on the environment. We design with the environment in mind, engineer our packaging to reduce materials, and provide collection and recycling programs. For more information, see:

- The Notices chapter
- The Environmental Sustainability section of the Lexmark Web site at www.lexmark.com/environment
- The Lexmark recycling program at www.lexmark.com/recycle

By selecting certain printer settings or tasks, you may be able to reduce your printer's impact even further. This chapter outlines the settings and tasks that may yield a greater environmental benefit.

Saving paper and toner

Using recycled paper and other office papers

As an environmentally conscious company, Lexmark supports the use of recycled office paper produced specifically for use in laser (electrophotographic) printers. In 1998, Lexmark presented to the US government a study demonstrating that recycled paper produced by major mills in the US fed as well as non-recycled paper. However, no blanket statement can be made that *all* recycled paper will feed well.

Lexmark consistently tests its printers with recycled paper (20–100% post-consumer waste) and a variety of test paper from around the world, using chamber tests for different temperature and humidity conditions. Lexmark has found no reason to discourage the use of today's recycled office papers, but generally the following property guidelines apply to recycled paper.

- Low moisture content (4–5%)
- Suitable smoothness (100–200 Sheffield units, or 140–350 Bendtsen units, European)

Note: Some much smoother papers (such as premium 24 lb laser papers, 50–90 Sheffield units) and much rougher papers (such as premium cotton papers, 200–300 Sheffield units) have been engineered to work very well in laser printers, despite surface texture. Before using these types of paper, consult your paper supplier.

- Suitable sheet-to-sheet coefficient of friction (0.4–0.6)
- Sufficient bending resistance in the direction of feed

Recycled paper, paper of lower weight (<60 g/m² [16 lb bond]) and/or lower caliper (<3.8 mils [0.1 mm]), and paper that is cut grain-short for portrait (or short-edge) fed printers may have lower bending resistance than is required for reliable paper feeding. Before using these types of paper for laser (electrophotographic) printing, consult your paper supplier. Remember that these are general guidelines only and that paper meeting these guidelines may still cause paper feeding problems in any laser printer (for example, if the paper curls excessively under normal printing conditions).

Conserving supplies

There are a number of ways you can reduce the amount of paper and toner you use when printing. You can:

Use both sides of the paper

If your printer model supports duplex printing, you can control whether print appears on one or two sides of the paper by selecting **2-sided printing** from the Print dialog or the Lexmark Toolbar.

Place multiple pages on one sheet of paper

You can print up to 16 consecutive pages of a multiple-page document onto one side of a single sheet of paper by selecting a setting from the Multipage printing (N-Up) section of the Print dialog.

Check your first draft for accuracy

Before printing or making multiple copies of a document:

- Use the preview feature, which you can select from the Print dialog or the Lexmark Toolbar, to see how the document will look before you print it.
- Print one copy of the document to check its content and format for accuracy.

Avoid paper jams

Carefully select and load paper to avoid paper jams. For more information, see “Avoiding jams” on page 148.



Saving energy

Using Eco-Mode

Use Eco-Mode to quickly select one or more ways to reduce your printer's environmental impact.

Note: See the table for the multiple settings that change when you select an Eco-Mode setting.

Choose	To
Energy	Reduce energy use, especially when the printer is idle. <ul style="list-style-type: none"> • Printer engine motors do not start until a job is ready to print. You may notice a short delay before the first page is printed. • The printer enters Power Saver mode after one minute of inactivity. • When the printer enters Power Saver mode, the printer control panel display light is turned off.
Paper	<ul style="list-style-type: none"> • Enable the automatic duplex feature (on printer models that support duplex). • Turn off print log features.
Energy/Paper	Use all the settings associated with Energy mode and Paper mode.
Off	Use factory default settings for all settings associated with Eco-Mode. This setting supports the performance specifications for your printer.

- 1 Make sure that the printer is on and **Ready** appears.
- 2 From the printer control panel, press .
- 3 Press the up or down arrow button until **Settings** appears, and then press .
- 4 Press the up or down arrow button until **General Settings** appears, and then press .

- 5 Press the up or down arrow button until **✓Eco-Mode** appears, and then press .
- 6 Press the left or right arrow button to scroll through the list of possible settings. Press at the correct setting. **Submitting Selection** appears.

Reducing printer noise

Use Quiet Mode to reduce printer noise.

Note: See the table for the multiple settings that change when you select a Quiet Mode setting.

Choose	To
On (Text/Graphics) Note: This setting is best suited for printing text and line graphics.	Reduce printer noise. <ul style="list-style-type: none"> • Print jobs will process at one-half the normal processing speed. • Printer engine motors do not start until a job is ready to print. There will be a short delay before the first page is printed. • Fans run at reduced speed or are turned off. • If your printer has faxing capability, fax sounds are reduced or disabled, including those made by the fax speaker and ringer. The fax is placed in standby mode. • The alarm control and cartridge alarm sounds are turned off. • The printer will ignore the Advance Start command.
Off (Image/Photo) Note: Selecting Photo from the driver may disable Quiet Mode and provide better print quality and full speed printing.	Use factory default settings. This setting supports the performance specifications for your printer.

- 1 Make sure that the printer is on and **Ready** appears.
- 2 From the printer control panel, press .
- 3 Press the up or down arrow button until **✓Settings** appears, and then press .
- 4 Press the up or down arrow button until **✓General Settings** appears, and then press .
- 5 Press the up or down arrow button until **✓Quiet Mode** appears, and then press .
- 6 Press the left or right arrow button to scroll through the list of possible settings. Press at the correct setting. **Submitting Selection** appears.

Adjusting Power Saver

Available settings range from 1–240 minutes. The factory default setting is 30 minutes.

To increase or decrease the number of minutes before the printer enters Power Saver mode, do one of the following:







Using the Embedded Web Server

- 1 Type the printer IP address into the address field of your Web browser.

Note: If you do not know the IP address of the printer, then print a network setup page and locate the IP address in the TCP/IP section.

- 2 Click **Settings**, and then click **General Settings**.
- 3 Click **Timeouts**.
- 4 In the Power Saver box, increase or decrease the number of minutes you want the printer to wait before it enters Power Saver mode.
- 5 Click **Submit**.

Using the printer control panel

- 1 Make sure the printer is on and **Ready** appears.
- 2 Press .
- 3 Press the up or down arrow button until **Settings** appears, and then press .
- 4 Press the up or down arrow button until **General Settings** appears, and then press .
- 5 Press the up or down arrow button until **Timeouts** appears, and then press .
- 6 Press the up or down arrow button until **Power Saver** appears, and then press .
- 7 Press the up or down arrow button to increase or decrease the number of minutes before the printer enters Power Saver mode, and then press .

Adjusting the brightness of the display

Using the Embedded Web Server



- 1 Type the printer IP address into the address field of your Web browser.

Note: If you do not know the IP address of the printer, then you can:

- View the IP address on the printer control panel in the TCP/IP section under the Networks/Ports menu.
- Print a network setup page or the menu settings pages and locate the IP address in the TCP/IP section.

- 2 Click **Settings**, and then click **Utilities Menu**.
- 3 In the LCD Brightness box, type in the brightness you want for your display. Available settings range from 1–10. The factory default setting is 5.
- 4 Click **Submit**.

Using the printer control panel

- 1 Make sure the printer is on and **Ready** appears.
- 2 Press .
- 3 Press the up or down arrow button until **Settings** appears, and then press .
- 4 Press the up or down arrow button until **Utilities Menu** appears, and then press .

- 5 Press the up or down arrow button until **√LCD Brightness** appears, and then press .
- 6 Press the up or down arrow button to select a setting, and then press .

Recycling

Lexmark provides collection programs and environmentally progressive approaches to recycling. For more information, see:

- The Notices chapter
- The Environmental Sustainability section of the Lexmark Web site at www.lexmark.com/environment
- The Lexmark recycling program at www.lexmark.com/recycle

Recycling Lexmark products

To return Lexmark products to Lexmark for recycling:

- 1 Visit our Web site at www.lexmark.com/recycle.
- 2 Find the product type you want to recycle, and then select your country from the list.
- 3 Follow the instructions on the computer screen.

Recycling Lexmark packaging

Lexmark continually strives to minimize packaging. Less packaging helps to ensure that Lexmark printers are transported in the most efficient and environmentally sensitive manner and that there is less packaging to dispose of. These efficiencies result in fewer greenhouse emissions, energy savings, and natural resource savings.

Lexmark cartons are 100% recyclable where corrugated recycling facilities exist. Facilities may not exist in your area.

The foam used in Lexmark packaging is recyclable where foam recycling facilities exist. Facilities may not exist in your area.

When you return a cartridge to Lexmark, you can reuse the box that the cartridge came in. Lexmark will recycle the box.

Returning Lexmark cartridges for reuse or recycling

The Lexmark Cartridge Collection Program diverts millions of Lexmark cartridges from landfills annually by making it both easy and free for Lexmark customers to return used cartridges to Lexmark for reuse or recycling. One hundred percent of the empty cartridges returned to Lexmark are either reused or demanufactured for recycling. Boxes used to return the cartridges are also recycled.







To return Lexmark cartridges for reuse or recycling, follow the instructions that came with your printer or cartridge and use the pre-paid shipping label. You can also:

- 1 Visit our Web site at www.lexmark.com/recycle.
- 2 From the Toner Cartridges section, select your country from the list.
- 3 Follow the instructions on the computer screen.

Loading paper and specialty media

This section explains how to load the standard tray (Tray 1), also known as the 550-sheet tray, an optional 550-sheet tray, an optional 2,000-sheet tray, a multipurpose feeder, and an optional 550-sheet specialty media drawer. It also includes information about paper orientation, setting the Paper Size and Paper Type, and linking and unlinking trays.

Setting the paper size and type

- 1 Make sure that the printer is on and **Ready** appears.
- 2 From the printer control panel, press .
- 3 Press the up or down arrow button until **✓Paper Menu** appears, and then press .
- 4 Press the up or down arrow button until **✓Paper Size/Type** appears, and then press .
- 5 Press the up or down arrow button until the correct tray or feeder appears, and then press .
- 6 Press the left or right arrow button until the correct size appears, and then press .
Paper Type appears.
- 7 Press the left or right arrow button until the correct type appears, and then press .
Submitting selection appears. The printer returns to the **Paper Size/Type** menu.

Loading the paper tray

The printer has up to five input sources to select from: the standard tray (Tray 1), also known as the 550-sheet tray, an optional 550-sheet tray, an optional 2,000-sheet tray, a multipurpose feeder, and an optional 550-sheet specialty media drawer. Load the paper or specialty media used for the majority of print jobs in Tray 1. Proper paper loading prevents jams and facilitates trouble-free printing.

Note: The C736n, C736dn, and C736dtn model printers will support a total of four optional input sources. The C734n, C734dn, C734dtn, and C734dnw model printers will support a total of three optional input sources.

Do not remove trays while a job prints or while **Busy** blinks on the printer control panel. Doing so may cause a jam.

- 1 Grasp the handle, and then pull the tray out. Remove the tray completely.

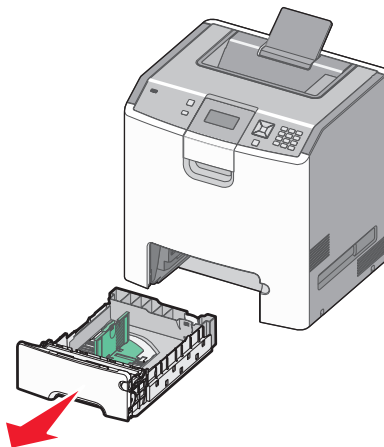

Notice the size indicators on the bottom of the tray. Use these indicators to help position the guides.

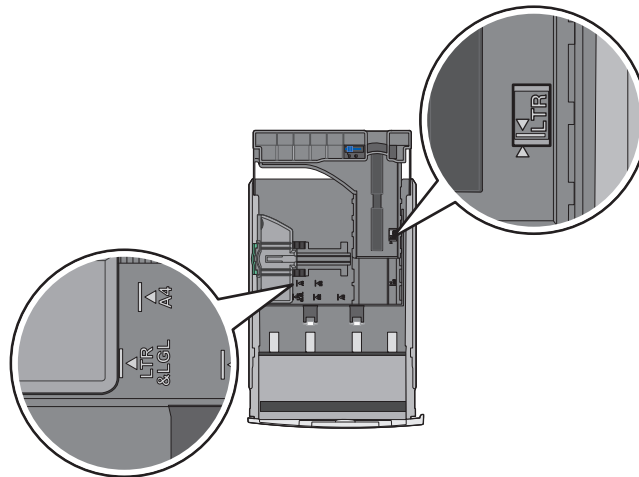

- 2 Squeeze the width guide tabs as shown, and then slide the guide to the correct position for the size of paper being loaded.

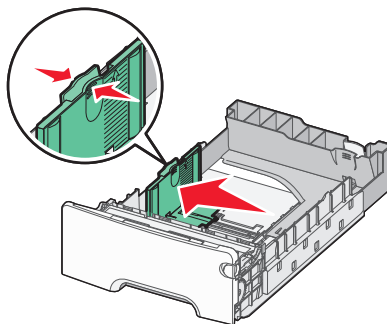

Notice the load line on the left side of the paper tray: it indicates the maximum height for loading paper.

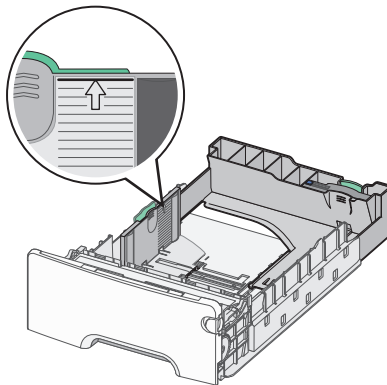

- 3 Squeeze the length guide tabs together, and then slide the length guide to the correct position for the size of paper being loaded.

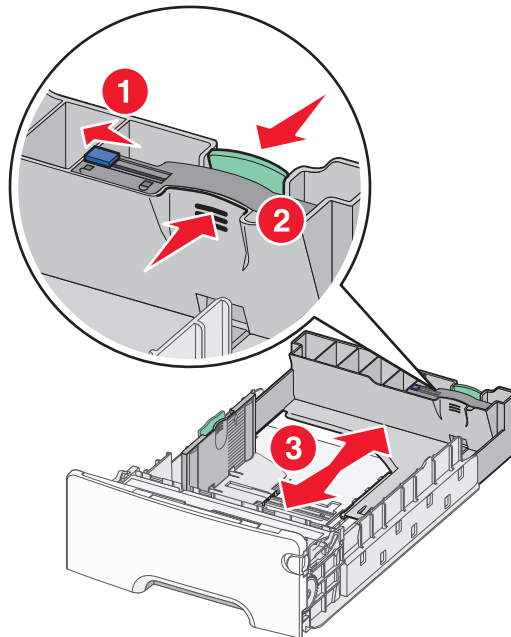

Note: The length guide has a locking device. To unlock the tray, slide the button on top of the length guide to the left as shown. To lock the tray once a length has been selected, slide the button back to the right.

- 4 Flex a stack of paper back and forth to loosen the sheets, and then fan them. Do not fold or crease the paper. Straighten the edges on a level surface.

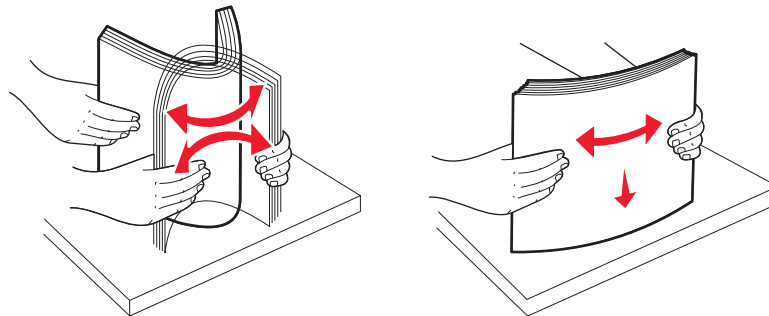

- 5 Load the paper stack with the recommended print side faceup. Load the stack toward the back of the tray as shown. When loading preprinted letterhead for simplex printing, place the header toward the front of the tray.

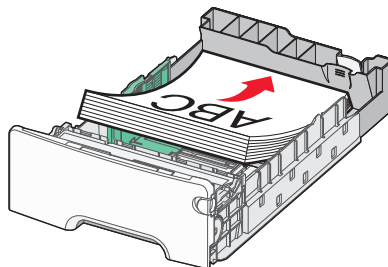

6 Align the tray, and then reinsert it.

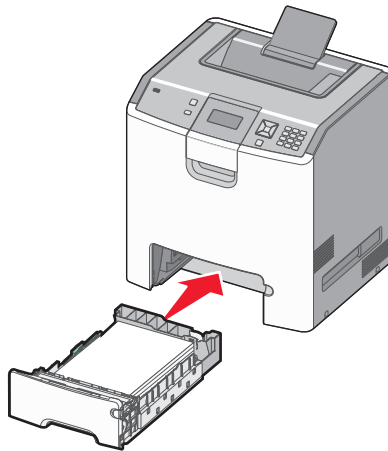

7 If a different type of paper was loaded than the type previously loaded in the tray, then change the paper type setting for the tray from the printer control panel. For more information, see “Setting the paper size and type” on page 52.

Loading the multipurpose feeder

The multipurpose feeder accommodates a variety of media types, including envelopes. Media not kept in a tray can be loaded into the multipurpose feeder.

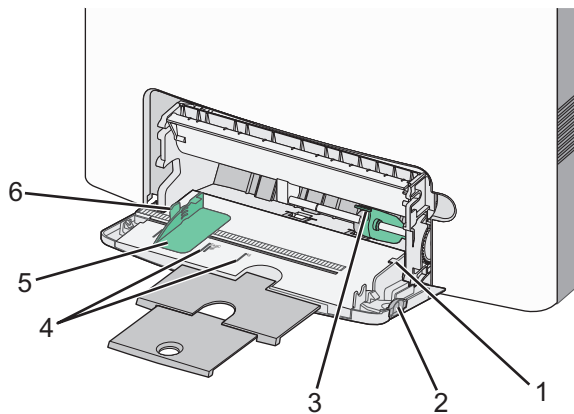

1	Stack height limiter
2	Tray release latch
3	Paper release lever
4	Size indicators

5	Width guide
6	Width guide release tab

- 1 Press the tray release latch to the left, and then pull the multipurpose feeder down.

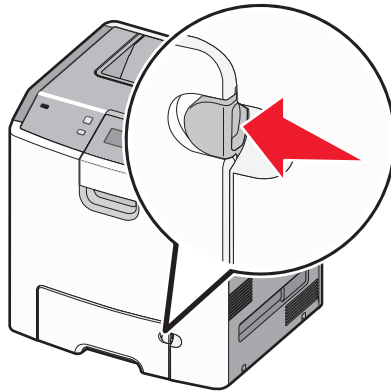

- 2 Gently pull the extension out until it is fully extended.

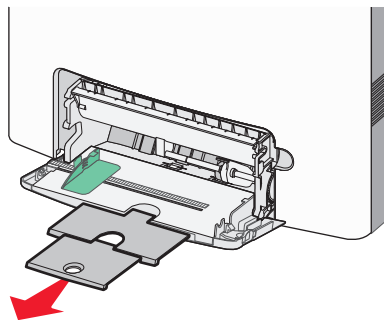

- 3 Prepare a media stack for loading.

- Flex sheets of paper back and forth to loosen them, and then fan them. Do not fold or crease the paper. Straighten the edges on a level surface.

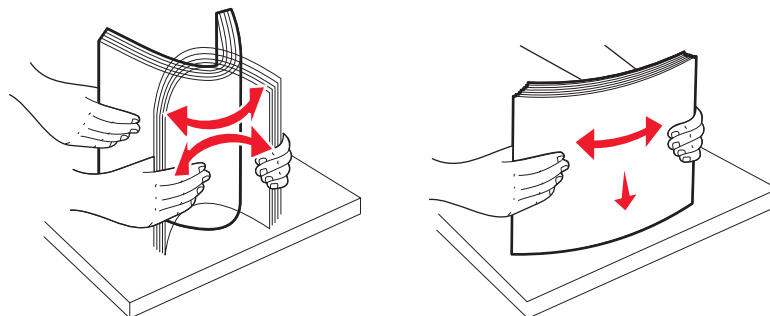

- Hold transparencies by the edges, and then fan them. Straighten the edges on a level surface.
Note: Avoid touching the print side of the transparencies. Be careful not to scratch them.

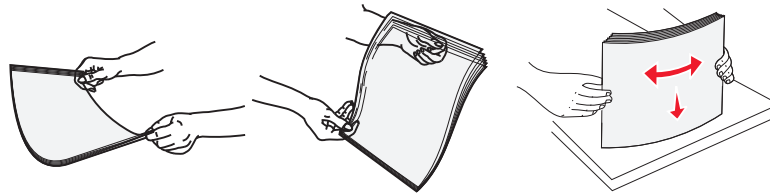

- Flex a stack of envelopes back and forth to loosen them, and then fan them. Straighten the edges on a level surface.

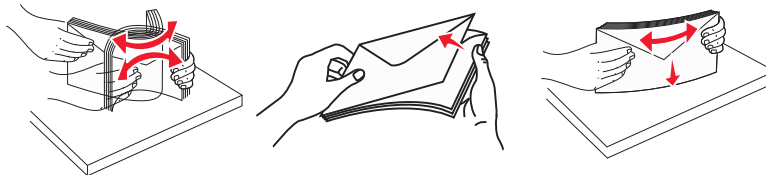

- 4 Load the media stack with the recommended print side facedown and the top edge entering the printer first.

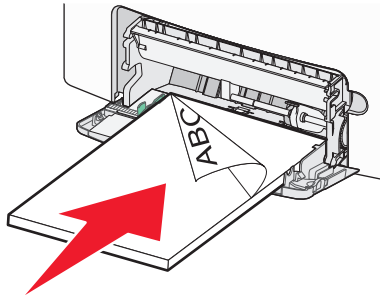

Note: Load only one size and type of media at a time.

- 5 Load envelopes with the flap side up and the return address edge entering the printer first.

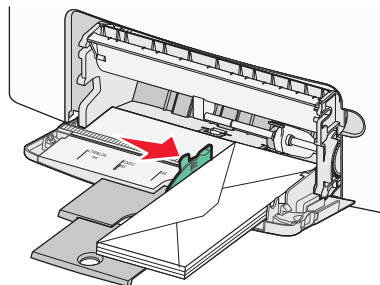

Warning—Potential Damage: Never use envelopes with stamps, clasps, snaps, windows, coated linings, or self-stick adhesives. These envelopes may severely damage the printer.

- 6 Make sure the media is as far into the multipurpose feeder as it will go with very gentle pushing. Media should lie flat and fit loosely in the multipurpose feeder.

Note: If the media is pushed too far into the multipurpose feeder, you must press the paper release lever to remove it.

- 7 From the printer control panel, set the Paper Size and Paper Type, and then press .

The multipurpose feeder can be closed when not in use.

Linking and unlinking trays

Linking trays

Tray linking is useful for large print jobs or multiple copies. When one linked tray is empty, paper feeds from the next linked tray. When the Paper Size and Paper Type settings are the same for any trays, the trays are automatically linked.

The printer automatically senses the Paper Size setting according to the position of the paper guides in each tray except the standard 550-sheet tray and the multipurpose feeder. The printer can sense A4, A5, JIS B5, Letter, Legal, Executive, and Universal paper sizes. The multipurpose feeder and trays using other paper sizes can be linked manually using the Paper Size menu available from the Paper Size/Type menu.

Note: To link the multipurpose feeder, Configure MP must be set to Cassette in the Paper menu in order for MP Feeder Size to appear as a menu item.

The Paper Type setting must be set for all trays from the Paper Type menu available from the Paper Size/Type menu.

Unlinking trays

Unlinked trays have settings that are *not* the same as the settings of any other tray.

To unlink a tray, change the following tray settings so that they do not match the settings of any other tray:

- Paper Type (for example: Plain Paper, Letterhead, Custom Type <x>)
Paper Type names describe the paper characteristics. If the name that best describes your paper is used by linked trays, assign a different Paper Type name to the tray, such as Custom Type <x>, or define your own custom name.
- Paper Size (for example: letter, A4, statement)
Load a different paper size to change the Paper Size setting for a tray automatically. Paper Size settings for the multipurpose feeder are not automatic; they must be set manually from the Paper Size menu.

Warning—Potential Damage: Do not assign a Paper Type name that does not accurately describe the type of paper loaded in the tray. The temperature of the fuser varies according to the specified Paper Type. Paper may not be properly processed if an inaccurate Paper Type is selected.

Creating a custom name for a paper type

If the printer is on a network, you can use the Embedded Web Server to define a name other than Custom Type <x> for each of the custom paper types that are loaded.

- 1 Type the printer IP address into the address field of your Web browser.

Note: If you do not know the IP address of the printer, print a network setup page and locate the address in the TCP/IP section.

- 2 Click **Settings**.

- 3 Click **Paper Menu**.

- 4 Click **Custom Name**.









- 5 Type a name for the paper type in a Custom Name <x> box.

Note: This custom name will replace a custom type <x> name under the Custom Types and Paper Size and Type menus.

- 6 Click **Submit**.
- 7 Click **Custom Types**.
Custom Types appears, followed by your custom name.
- 8 Select a Paper Type setting from the pick list next to your custom name.
- 9 Click **Submit**.

Assigning a custom paper type name to a tray

Assign a Custom Type <x> name to a tray to link or unlink it. Associate the same Custom Type <x> name to each tray that you want to link. Only trays with the same custom names assigned will link.

- 1 Make sure the printer is on and **Ready** appears.
- 2 From the printer control panel, press .
- 3 Press the up or down arrow button until **✓Paper Menu** appears, and then press .
- 4 Press the up or down arrow button until **✓Paper Size/Type** appears, and then press .
- 5 Press the up or down arrow button until the correct tray or feeder appears, and then press .
- 6 Press the left or right arrow button until the correct size appears, and then press .
- Paper Type** appears.
- 7 Press the left or right arrow button until **✓Custom Type <x>** or another custom name appears, and then press .
- Submitting selection** appears, followed by **Paper Menu**.
- 8 Verify that the correct Paper Type is associated with the custom name.
Note: Plain Paper is the factory default Paper Type associated with all Custom Type <x> names and user-defined custom names.
 - a From the Paper menu, press the up or down arrow button until **✓Custom Types** appears, and then press .
 - b Press the up or down arrow button until **✓** appears next to the custom paper type name, and then press .
 - c Press the up or down arrow button until **✓** appears next to the Paper Type setting you want, and then press .**Submitting selection** appears.

Paper and specialty media guidelines

Paper guidelines

Paper characteristics

The following paper characteristics affect print quality and reliability. Consider these characteristics when evaluating new paper stock.

Weight

The printer can automatically feed paper weights from 60 to 220 g/m² (16 to 58 lb bond) grain long. Paper lighter than 60 g/m² (16 lb) might not be stiff enough to feed properly, causing jams. For best performance, use 75-g/m² (20-lb bond) grain long paper. For paper smaller than 182 x 257 mm (7 x 10 in.), we recommend 90 g/m² (24 lb) or heavier paper.

Note: Duplex is supported only for 60-g/m²–120-g/m² (16-lb–32-lb bond) paper.

Curl

Curl is the tendency for paper to curl at its edges. Excessive curl can cause paper feeding problems. Curl can occur after the paper passes through the printer, where it is exposed to high temperatures. Storing paper unwrapped in hot, humid, cold, or dry conditions, even in the trays, can contribute to paper curling prior to printing and can cause feeding problems.

Smoothness

Paper smoothness directly affects print quality. If paper is too rough, toner cannot fuse to it properly. If paper is too smooth, it can cause paper feeding or print quality issues. Always use paper between 100 and 300 Sheffield points; however, smoothness between 150 and 200 Sheffield points produces the best print quality.

Moisture content

The amount of moisture in paper affects both print quality and the ability of the printer to feed the paper correctly. Leave paper in its original wrapper until it is time to use it. This limits the exposure of paper to moisture changes that can degrade its performance.

Condition paper before printing by storing it in its original wrapper in the same environment as the printer for 24 to 48 hours before printing. Extend the time several days if the storage or transportation environment is very different from the printer environment. Thick paper may also require a longer conditioning period.

Grain direction

Grain refers to the alignment of the paper fibers in a sheet of paper. Grain is either *grain long*, running the length of the paper, or *grain short*, running the width of the paper.

For 60- to 135-g/m² (16- to 36-lb bond) paper, grain long paper is recommended. For papers heavier than 135 g/m², grain short is recommended.

Fiber content

Most high-quality xerographic paper is made from 100% chemically treated pulped wood. This content provides the paper with a high degree of stability resulting in fewer paper feeding problems and better print quality. Paper containing fibers such as cotton can negatively affect paper handling.

Unacceptable paper

The following paper types are not recommended for use with the printer:

- Chemically treated papers used to make copies without carbon paper, also known as carbonless papers, carbonless copy paper (CCP), or no carbon required (NCR) paper
- Preprinted papers with chemicals that may contaminate the printer
- Preprinted papers that can be affected by the temperature in the printer fuser
- Preprinted papers that require a registration (the precise print location on the page) greater than ± 2.3 mm (± 0.9 in.), such as optical character recognition (OCR) forms

In some cases, registration can be adjusted with a software application to successfully print on these forms.

- Coated papers (erasable bond), synthetic papers, thermal papers
- Rough-edged, rough or heavily textured surface papers, or curled papers
- Recycled papers that fail EN12281:2002 (European)
- Paper weighing less than 60 g/m^2 (16 lb)
- Multiple-part forms or documents

Selecting paper

Using appropriate paper prevents jams and helps ensure trouble-free printing.

To help avoid jams and poor print quality:

- *Always* use new, undamaged paper.
- Before loading paper, know the recommended print side of the paper. This information is usually indicated on the paper package.
- *Do not* use paper that has been cut or trimmed by hand.
- *Do not* mix paper sizes, types, or weights in the same source; mixing results in jams.
- *Do not* use coated papers unless they are specifically designed for electrophotographic printing.

Selecting preprinted forms and letterhead

Use these guidelines when selecting preprinted forms and letterhead:

- Use grain long for 60 to 90 g/m^2 (16 to 24 lb) weight paper.
- Use only forms and letterhead printed using an offset lithographic or engraved printing process.
- Avoid papers with rough or heavily textured surfaces.

Use papers printed with heat-resistant inks designed for use in xerographic copiers. The ink must be able to withstand temperatures up to 190°C (374°F) without melting or releasing hazardous emissions. Use inks that are not affected by the resin in toner. Inks that are oxidation-set or oil-based generally meet these requirements; latex inks might not. When in doubt, contact the paper supplier.

Preprinted papers such as letterhead must be able to withstand temperatures up to 190°C (374°F) without melting or releasing hazardous emissions.

Storing paper

Use these paper storage guidelines to help avoid jams and uneven print quality:

- For best results, store paper where the temperature is 21°C (70°F) and the relative humidity is 40%. Most label manufacturers recommend printing in a temperature range of 18 to 24°C (65 to 75°F) with relative humidity between 40 and 60%.
- Store paper in cartons when possible, on a pallet or shelf, rather than on the floor.
- Store individual packages on a flat surface.
- Do not store anything on top of individual paper packages.

Supported paper sizes, types, and weights

The following tables provide information on standard and optional paper input sources and the types of paper they support.

Note: To use a paper size that is unlisted, configure a Universal Paper Size.

For more information, see the *Card Stock & Label Guide* available on the Lexmark Web site at <http://support.lexmark.com>.

Paper sizes supported by the printer

Measurements apply to simplex (one-sided) printing only. For duplex (two-sided) printing, the minimum size is 139.7 x 210 mm (5.50 x 8.27 in.).

Paper size	Dimensions	Standard 550-sheet tray (Tray 1)	Optional 550-sheet tray	Optional 550-sheet specialty media drawer	Optional 2,000-sheet tray	Multipurpose feeder	Duplex unit
A4	210 x 297 mm (8.27 x 11.7 in.)	✓	✓	✓	✓	✓	✓
A5	148 x 210 mm (5.83 x 8.27 in.)	✓	✓	✓	X	✓	✓
A6	105 x 148 mm (4.13 x 5.83 in.)	X	X	✓	X	✓	X
JIS B5	182 x 257 mm (7.17 x 10.1 in.)	✓	✓	✓	X	✓	✓

¹ Supported by C734 model printers only.

² Supported by C736 model printers only.

³ This size setting formats the envelope for 215.9 x 355.6 mm (8.5 x 14 in.) unless the size is specified by the software application.

Paper size	Dimensions	Standard 550-sheet tray (Tray 1)	Optional 550-sheet tray	Optional 550-sheet specialty media drawer	Optional 2,000-sheet tray	Multipurpose feeder	Duplex unit
Letter	215.9 x 279.4 mm (8.5 x 11 in.)	✓	✓	✓	✓	✓	✓
Legal	215.9 x 355.6 mm (8.5 x 14 in.)	✓	✓	✓	✓	✓	✓
Executive	184.2 x 266.7 mm (7.25 x 10.5 in.)	✓	✓	✓	X	✓	✓
Oficio (México)	215.9 x 340.4 mm (8.5 x 13.4 in.)	✓	✓	✓	X	✓	✓
Folio	215.9 x 330.2 mm (8.5 x 13 in.)	✓	✓	✓	X	✓	✓
Statement	139.7 x 215.9 mm (5.5 x 8.5 in.)	X	X	✓	X	✓	✓
Universal Note: Turn size sensing off to support universal sizes that are close to standard media sizes.	148 x 210 mm to 215.9 x 355.6 mm (5.83 x 8.27 in. to 8.5 x 14 in.)	✓	✓	✓	X	✓	✓
	76.2 x 127 mm (3 x 5 in.) to 215.9 x 355.6 mm (8.5 x 14 in.)	X	X	✓	X	✓	X
	76.2 x 127 mm (3 x 5 in.) to 215.9 x 914.4 mm (8.5 x 36 in.) ¹	X	X	X	X	✓	X
	76.2 x 127 mm (3 x 5 in.) to 215.9 x 1219.2 mm (8.5 x 48 in.) ²	X	X	X	X	✓	X
7 3/4 Envelope (Monarch)	98.4 x 190.5 mm (3.875 x 7.5 in.)	X	X	✓	X	✓	X
9 Envelope	98.4 x 226.1 mm (3.875 x 8.9 in.)	X	X	✓	X	✓	X
Com 10 Envelope	104.8 x 241.3 mm (4.12 x 9.5 in.)	X	X	✓	X	✓	X
DL Envelope	110 x 220 mm (4.33 x 8.66 in.)	X	X	✓	X	✓	X

¹ Supported by C734 model printers only.

² Supported by C736 model printers only.

³ This size setting formats the envelope for 215.9 x 355.6 mm (8.5 x 14 in.) unless the size is specified by the software application.

Paper size	Dimensions	Standard 550-sheet tray (Tray 1)	Optional 550-sheet tray	Optional 550-sheet specialty media drawer	Optional 2,000-sheet tray	Multipurpose feeder	Duplex unit
C5 Envelope	162 x 229 mm (6.38 x 9.01 in.)	X	X	✓	X	✓	X
B5 Envelope	176 x 250 mm (6.93 x 9.84 in.)	X	X	✓	X	✓	X
Other Envelope³	85.7 x 165 mm to 215.9 x 355.6 mm (3.375 x 6.50 in. to 8.5 x 14 in.)	X	X	✓	X	✓	X

¹ Supported by C734 model printers only.

² Supported by C736 model printers only.

³ This size setting formats the envelope for 215.9 x 355.6 mm (8.5 x 14 in.) unless the size is specified by the software application.

Paper types and weights supported by the printer

The printer engine supports 60–220-g/m² (16–58-lb) paper weights. The duplex unit supports 60–120-g/m² (16–32-lb) paper weights.

Note: Labels, transparencies, envelopes, and card stock always print at reduced speed.

Paper type	Standard 550-sheet tray (Tray 1)	Optional 550-sheet tray	Optional 550-sheet specialty media drawer	Optional 2,000-sheet tray	Multipurpose feeder	Duplex unit
Paper <ul style="list-style-type: none"> • Plain • Bond • Colored • Custom Type [x] • Letterhead • Light • Heavy • Preprinted • Rough/Cotton¹ • Recycled 	✓	✓	✓	✓	✓	✓
Card stock	✓	✓	✓	X	✓	X
Transparencies²	✓	✓	✓	X	✓	X
Labels³ <ul style="list-style-type: none"> • Paper • Vinyl 	✓	✓	✓	X	✓	X
Glossy paper	✓	✓	✓	✓	✓	✓
Envelopes⁴	X	X	✓	X	✓	X

¹ This option is not supported by the duplex unit.

² Do not use inkjet or 3M CG3710 transparencies.

³ Paper labels are supported. Other media such as vinyl may show print quality defects in some environments, and prolonged vinyl label usage may reduce fuser life. For more information, see the *Card Stock & Label Guide* available on the Lexmark Web site at <http://support.lexmark.com>.

⁴ Use envelopes that lie flat when individually placed on a table facedown.

Printing

This chapter covers printing, printer reports, and job cancelation. The selection and handling of paper and specialty media can affect how reliably documents print. For more information, see "Avoiding jams" and "Storing paper."

Printing a document

Printing a document

- 1 Load paper into a tray or feeder.
- 2 From the printer control panel Paper menu, set the Paper Size/Type to match the loaded paper.
- 3 Send the print job:

For Windows users

- a With a document open, click **File > Print**.
- b Click **Properties, Preferences, Options, or Setup**, and then adjust the settings as needed.

Note: To print on a specific size or type of paper, adjust the paper size or type settings to match the loaded paper, or select the appropriate tray or feeder.

- c Click **OK**, and then click **OK**.

For Macintosh users

- a Customize the settings as needed in the Page Setup dialog:
 - 1 With a document open, choose **File > Page Setup**.
 - 2 Choose a paper size or create a custom size to match the loaded paper.
 - 3 Click **OK**.
- b Customize the settings as needed in the Print dialog:
 - 1 With a document open, choose **File > Print**.
If necessary, click the disclosure triangle to see more options.
 - 2 From the Print dialog and pop-up menus, adjust the settings as needed.

Note: To print on a specific paper type, adjust the paper type setting to match the loaded paper, or select the appropriate tray or feeder.

- 3 Click **Print**.

Printing specialty documents

Tips on using letterhead

Source or process	Print side	Paper orientation
<ul style="list-style-type: none"> • Standard 550-sheet tray • Optional 550-sheet tray • Optional 2,000-sheet tray • Optional 550-sheet specialty media drawer 	Preprinted letterhead design is placed faceup.	The top edge of the sheet with the logo is placed at the front of the tray.
Duplex (two-sided) printing from trays	Preprinted letterhead design is placed facedown.	The top edge of the sheet with the logo is placed at the back of the tray.
Multipurpose feeder (simplex printing)	Preprinted letterhead design is placed facedown.	The top edge of the sheet with the logo should enter the multipurpose feeder first.
Multipurpose feeder (duplex printing)	Preprinted letterhead design is placed faceup.	The top edge of the sheet with the logo should enter the multipurpose feeder last.
Note: Check with the manufacturer or vendor to determine whether the chosen preprinted letterhead is acceptable for laser printers.		

Tips on using transparencies

Print samples on the transparencies being considered for use before buying large quantities.

When printing on transparencies:

- Feed transparencies from any tray or drawer, except the Optional 2,000-sheet tray.
- Use transparencies designed specifically for laser printers. Check with the manufacturer or vendor to ensure transparencies are able to withstand temperatures up to 170°C (338°F) without melting, discoloring, offsetting, or releasing hazardous emissions.
- To prevent print quality problems, avoid getting fingerprints on the transparencies.
- Before loading transparencies, fan the stack to prevent sheets from sticking together.
- We recommend Lexmark part number 12A8240 for letter-size transparencies and Lexmark part number 12A8241 for A4-size transparencies.

Tips on using envelopes

Print samples on the envelopes being considered for use before buying large quantities.

When printing on envelopes:

- Use envelopes designed specifically for laser printers. Check with the manufacturer or vendor to ensure the envelopes can withstand temperatures up to 190°C (374°F) without sealing, wrinkling, curling excessively, or releasing hazardous emissions.
- For the best performance, use envelopes made from 90 g/m² (24 lb bond) paper. Use up to 105 g/m² (28 lb bond) weight for envelopes as long as the cotton content is 25% or less. All-cotton envelopes must not exceed 90 g/m² (24 lb bond) weight.

- Use only new envelopes.
- To optimize performance and minimize jams, do not use envelopes that:
 - Have excessive curl or twist
 - Are stuck together or damaged in any way
 - Have windows, holes, perforations, cutouts, or embossing
 - Have metal clasps, string ties, or folding bars
 - Have an interlocking design
 - Have postage stamps attached
 - Have any exposed adhesive when the flap is in the sealed or closed position
 - Have bent corners
 - Have rough, cockle, or laid finishes
- Adjust the width guides to fit the width of the envelopes.

Note: A combination of high humidity (over 60%) and the high printing temperature may wrinkle or seal envelopes.

Tips on using labels

Print samples on the labels being considered for use before buying large quantities.

Note: Paper labels are supported. Other media such as vinyl may show print quality defects in some environments, and prolonged vinyl label usage may reduce fuser life.

For detailed information on label printing, characteristics, and design, see the *Card Stock & Label Guide* available on the Lexmark Web site at <http://support.lexmark.com>.

When printing on labels:

- Use labels designed specifically for laser printers. Check with the manufacturer or vendor to verify that:
 - The labels can withstand temperatures up to 190°C (374°F) without sealing, excessive curling, wrinkling, or releasing hazardous emissions.
 - Label adhesives, face sheet (printable stock), and topcoats can withstand up to 25 psi (172 kPa) pressure without delaminating, oozing around the edges, or releasing hazardous fumes.
- Do not use labels with slick backing material.
- Use full label sheets. Partial sheets may cause labels to peel off during printing, resulting in a jam. Partial sheets also contaminate the printer and the cartridge with adhesive, and could void the printer and cartridge warranties.
- Do not use labels with exposed adhesive.
- Do not print within 1 mm (0.04 in.) of the edge of the label, of the perforations, or between die-cuts of the label.
- Be sure adhesive backing does not reach to the sheet edge. Zone coating of the adhesive at least 1 mm (0.04 in.) away from edges is recommended. Adhesive material contaminates the printer and could void the warranty.
- If zone coating of the adhesive is not possible, remove a 1.6 mm (0.06 in.) strip on the leading and driver edge, and use a non-oozing adhesive.
- Portrait orientation works best, especially when printing bar codes.

Tips on using card stock

Card stock is heavy, single-ply specialty media. Many of its variable characteristics, such as moisture content, thickness, and texture, can significantly impact print quality. Print samples on the card stock being considered for use before buying large quantities.

When printing on card stock:

- Make sure the Paper Type is Card Stock.
- Select the appropriate Paper Texture setting.
- Be aware that preprinting, perforation, and creasing may significantly affect the print quality and cause jams or other paper-handling problems.
- Check with the manufacturer or vendor to ensure the card stock can withstand temperatures up to 190°C (374°F) without releasing hazardous emissions.
- Do not use preprinted card stock manufactured with chemicals that may contaminate the printer. Preprinting introduces semi-liquid and volatile components into the printer.
- Use grain short card stock when possible.

Printing confidential and other held jobs

Holding jobs in the printer

When sending a job to the printer, you can specify that you want the printer to hold the job in memory until you start the job from the printer control panel. All print jobs that can be initiated by the user at the printer are called *held jobs*.

Note: Confidential, Verify, Reserve, and Repeat print jobs may be deleted if the printer requires extra memory to process additional held jobs.

Job type	Description
Confidential	When you send a Confidential print job to the printer, you must create a PIN from the computer. The PIN must be four digits using the numbers 0–9. The job is held in printer memory until you enter the PIN from the printer control panel and choose to print or delete the job.
Verify	When you send a Verify print job, the printer prints one copy and holds the remaining copies in printer memory. Verify lets you examine the first copy to see if it is satisfactory before printing the remaining copies. Once all copies are printed, the job is automatically deleted from printer memory.
Reserve	When you send a Reserve print job, the printer does not print the job immediately. It stores the job in memory so you can print the job later. The job is held in memory until you delete it from the Held Jobs menu.
Repeat	When you send a Repeat print job, the printer prints all requested copies of the job <i>and</i> stores the job in memory so you can print additional copies later. You can print additional copies as long as the job remains stored in memory.

Printing confidential and other held jobs

Note: Confidential and Verify print jobs are automatically deleted from memory after they print. Repeat and Reserve jobs continue to be held in the printer until you choose to delete them.

For Windows Users

- 1 With a document open, click **File > Print**.
 - 2 Click **Properties, Preferences, Options, or Setup**.
 - 3 Click **Other Options**, and then click **Print and Hold**.
 - 4 Select your job type (Confidential, Repeat, Reserve, or Verify), and then assign a user name. For a confidential job, also enter a four-digit PIN.
 - 5 Click **OK** or **Print**, and then go to the printer to release the job.
 - 6 From the printer control panel, press the up or down arrow button until **✓Held jobs** appears, and then press .
 - 7 Press the up or down arrow button until **✓** appears next to your user name, and then press .
 - 8 Press the up or down arrow button until **✓** appears next to the job type or job name, and then press .
If you selected a job name, proceed to step 11 on page 70.
 - 9 After selecting your job type, use the keypad to enter your PIN.
If you enter an invalid PIN, the Invalid PIN screen appears.
 - To re-enter the PIN, make sure **✓Try again** appears, and then press .
 - To cancel the PIN, press the up or down arrow button until **✓Cancel** appears, and then press .
 - 10 Press the up or down arrow button until **✓** appears next to the job you want to print, and then press .
 - 11 Press the up or down arrow button until **✓** appears next to the number of copies you want to print, and then press .
- Note:** Use the keypad to enter a number if necessary.

For Macintosh users

- 1 With a document open, choose **File > Print**.
If necessary, click the disclosure triangle to see more options.
- 2 From the print options or Copies & Pages pop-up menu, choose **Job Routing**.
- 3 Select your job type (Confidential, Repeat, Reserve, or Verify), and then assign a user name. For a confidential job, also enter a four-digit PIN.
- 4 Click **OK** or **Print**, and then go to the printer to release the job.
- 5 From the printer control panel, press the up or down arrow button until **✓Held jobs** appears, and then press .
- 6 Press the up or down arrow button until **✓** appears next to your user name, and then press .
- 7 Press the up or down arrow button until **✓** appears next to the job type or job name, and then press .
If you selected a job name, proceed to step 10 on page 71.

8 After selecting your job type, use the keypad to enter your PIN.

If you enter an invalid PIN, the Invalid PIN screen appears.

- To re-enter the PIN, make sure **✓Try again** appears, and then press .
- To cancel the PIN, press the up or down arrow button until **✓Cancel** appears, and then press .

9 Press the up or down arrow button until **✓** appears next to the job you want to print, and then press .

10 Press the up or down arrow button until **✓** appears next to the number of copies you want to print, and then press .

Note: Use the keypad to enter a number if necessary.

Printing from a flash drive

A USB port is located on the printer control panel. Insert a flash drive to print supported file types. Supported file types include: .pdf, .gif, .jpeg, .jpg, .bmp, .png, .tiff, .tif, .pcx, .xps, and .dcx.

Notes:

- High-speed flash drives must support the full-speed USB standard. Flash drives supporting only USB low-speed capabilities are not supported.
- Flash drives must support the FAT (*File Allocation Tables*) system. Flash drives formatted with NTFS (*New Technology File System*) or any other file system are not supported.
- Before printing an encrypted .pdf file, enter the file password from the printer control panel.
- You cannot print files for which you do not have printing permissions.

1 Make sure the printer is on and **Ready** appears.

2 Insert a flash drive into the front USB port.

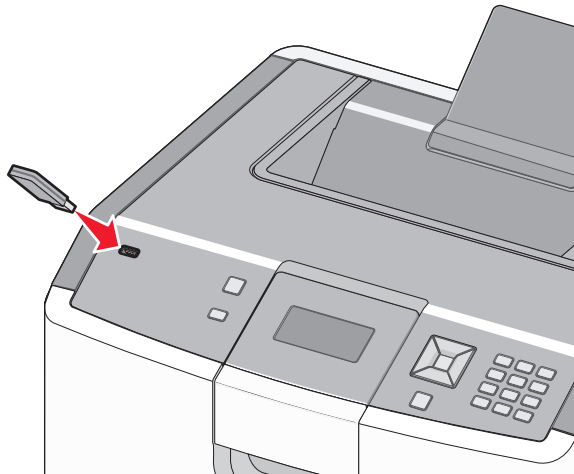

Notes:

- If you insert the flash drive when the printer requires attention, such as when a jam has occurred, then the printer ignores it.
- If you insert the flash drive while the printer is printing other jobs, then **Printer Busy** appears. After the other jobs are processed, you may need to view the held jobs list to print documents from the flash drive.

- 3 Press the up or down arrow button until appears next to the document you want to print, and then press .

Note: Folders found on the flash drive appear as folders. File names are appended by the extension type (for example, .jpg).

- 4 Press to print one copy, or enter the number of copies using the keypad, and then press to initiate the print job.

Note: Do not remove the flash drive from the printer until the document has finished printing.

If you leave the flash drive in the printer after leaving the initial USB menu screen, you can still print .pdf files from the flash drive as held jobs.

Printing photos from a PictBridge-enabled digital camera

- 1 Insert one end of the USB cable into the camera.

Note: Use only the USB cable that came with your camera.

- 2 Insert the other end of the USB cable into the USB port on the front of the printer.

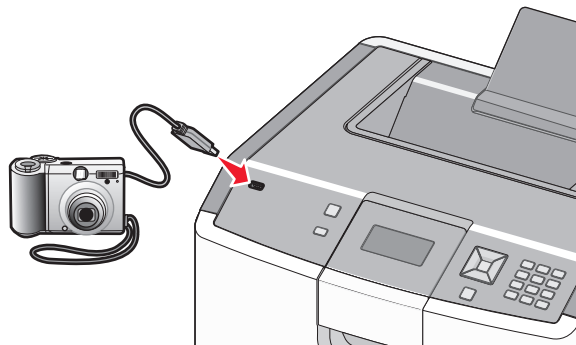

Notes:

- Make sure the PictBridge-enabled digital camera is set to the correct USB mode. For more information, see the camera documentation.
- If the PictBridge connection is successful, then a confirmation message appears on the printer display.

- 3 Follow the instructions on the camera to select and print photos.

Note: If the printer is turned off while the camera is connected, then you must disconnect and then reconnect the camera.

Printing information pages

Printing a font sample list

To print samples of the fonts currently available for your printer:

- 1 Make sure the printer is on and **Ready** appears.
- 2 From the printer control panel, press .
- 3 Press the up or down arrow button until **Reports** appears, and then press .

- 4 Press the up or down arrow button until **✓Print Fonts** appears, and then press .
- 5 Press the up or down arrow button until **✓** appears next to **PCL Fonts, PostScript Fonts, or PPDS Fonts**, and then press .

After the font sample list prints, **Ready** appears.

Printing a directory list

A directory list shows the resources stored in flash memory or on the hard disk.

- 1 Make sure the printer is on and **Ready** appears.
- 2 From the printer control panel, press .
- 3 Press the up or down arrow button until **✓Reports** appears, and then press .
- 4 Press the up or down arrow button until **✓Print Directory** appears, and then press .

After the directory list prints, the printer returns to the **Ready** state.

Printing the print quality test pages

Print the print quality test pages to isolate print quality problems.

- 1 Turn the printer off.
- 2 Hold down and the right arrow button while turning the printer on.
- 3 Release the buttons when the clock appears, and wait for **CONFIG MENU** to appear.
- 4 Press the up or down arrow button until **✓Prt Quality Pgs** appears, and then press .
The print quality test pages print.
- 5 Press the up or down arrow button until **✓Exit Config Menu** appears, and then press .
Resetting the Printer appears briefly, followed by a clock, and then **Ready** appears.

Canceling a print job

Canceling a print job from the printer control panel

If the job is formatting or already printing, and **Cancel a job** appears on the first line of the display:

- 1 Press the up or down arrow button until **✓Cancel** appears.
A list of jobs appears.
- 2 Press the up or down arrow button until **✓** appears next to the job you want to cancel, and then press .

Note: Once a print job is sent, to easily cancel a job, press . The **Stopped** screen appears. Press the up or down arrow button until **✓Cancel a job** appears, and then press .

Canceling a print job from the computer

For Windows users

- 1 Open the printers folder:
 - a Click , or click **Start** and then click **Run**.
 - b In the Start Search or Run box, type **control printers**.
 - c Press **Enter**, or click **OK**.
The printers folder opens.
- 2 Double-click the printer icon.
- 3 Select the job to cancel.
- 4 From the keyboard, press **Delete**.

From the Windows taskbar:

When you send a job to print, a small printer icon appears in the right corner of the taskbar.

- 1 Double-click the printer icon.
A list of print jobs appears in the printer window.
- 2 Select a job to cancel.
- 3 From the keyboard, press **Delete**.

For Macintosh users

In Mac OS X version 10.5 or later:

- 1 From the Apple menu, choose **System Preferences**.
- 2 Click **Print & Fax**, and then double-click the printer icon.
- 3 From the printer window, select the job to cancel.
- 4 From the icon bar at the top of the window, click the **Delete** icon.





In Mac OS X version 10.4 and earlier:

- 1 From the Go menu, choose **Applications**.
- 2 Double-click **Utilities**, and then double-click **Printer Setup Utility** or **Print Center**.
- 3 Double-click the printer icon.
- 4 From the printer window, select the job to cancel.
- 5 From the icon bar at the top of the window, click the **Delete** icon.

Printing in black and white

To print all text and graphics using only the black toner cartridge, set the printer to Black Only.

Note: The printer driver is capable of overriding this setting.

- 1 From the printer control panel, press .
 - 2 Press the up or down arrow button until **Settings** appears, and then press .
 - 3 Press the up or down arrow button until **Quality Menu** appears, and then press .
 - 4 Press the up or down arrow button until **Print Mode** appears, and then press .
 - 5 Press the up or down arrow button until **Black Only** appears, and then press .
- Submitting selection** appears.

Using Max Speed and Max Yield

The Max Speed and Max Yield settings let you choose between a faster print speed or a higher toner yield. Max Yield is the factory default setting.

- **Max Speed**—Prints in color mode unless black only is selected by the driver. Prints in black only mode if the black only driver setting is selected.
- **Max Yield**—Switches from black to color mode based on the color content found on each page. Frequent color mode switching can result in slower printing if the content of pages is mixed.

- 1 Type the printer IP address into the address field of your Web browser.

Note: If you do not know the IP address of the printer, then print a network setup page and locate the address in the TCP/IP section.

- 2 Click **Settings**.
- 3 Click **Print Settings**.
- 4 Click **Setup Menu**.
- 5 From the Printer Usage list, select **Max Speed** or **Max Yield**.
- 6 Click **Submit**.

Understanding printer menus

Menus list

Supplies

Replace Supply
 Cyan Cartridge
 Magenta Cartridge
 Yellow Cartridge
 Black Cartridge
 Cyan Photoconductor
 Magenta Photoconductor
 Yellow Photoconductor
 Black Photoconductor
 Waste Toner Box
 Fuser
 Transfer Module

Paper Menu

Default Source
 Paper Size/Type
 Configure MP
 Substitute Size
 Paper Texture
 Paper Weight
 Paper Loading
 Custom Types
 Universal Setup

Reports

Menu Settings Page
 Device Statistics
 Network Setup Page
 Network <x> Setup Page
 Profiles List
 NetWare Setup Page
 Print Fonts
 Print Directory
 Asset Report

Settings

General Settings
 Setup Menu
 Finishing Menu
 Quality Menu
 Utilities Menu
 XPS Menu
 PDF Menu
 PostScript Menu
 PCL Emul Menu
 HTML Menu
 Image Menu
 PictBridge Menu
 Flash Drive Menu

Security

Miscellaneous Security Settings
 Confidential Print
 Disk Wiping
 Security Audit Log
 Set Date/Time

Network/Ports

Active NIC
 Standard Network*
 Standard USB
 Parallel <x>
 Serial <x>
 SMTP Setup

Help

Print All
 Color Quality
 Print Quality
 Printing Guide
 Media Guide
 Print Defects
 Menu Map
 Information Guide
 Connection Guide
 Moving Guide
 Supplies Guide

*Depending on the printer setup, this menu item appears as Standard Network, Wireless Network, or Network <x>.

Supplies menu

Supplies menu

Menu item	Description
Replace Supply All Cyan Photoconductor Magenta Photoconductor Yellow Photoconductor Black Photoconductor	Provides the option to reset the supply counter for the photoconductor just replaced, or for all photoconductors Select the photoconductor, and then select Yes or No: <ul style="list-style-type: none"> • Select Yes to reset the supply counter. • Select No to exit. Note: A supply counter must be reset manually after a photoconductor is replaced.
Cyan, Magenta, Yellow, or Black Cartridge Early Warning Low Invalid Replace Missing or Defective OK Unsupported	Shows the status of the toner cartridges
Cyan, Magenta, Yellow, or Black Photoconductor Early Warning Low Replace Missing OK	Shows the status of the photoconductors
Waste Toner Box Near Full Replace Missing OK	Shows the status of the waste toner box
Fuser Early Warning Low Replace Missing OK	Shows the status of the fuser
Transfer module Early Warning Low Replace Missing OK	Shows the status of the transfer module

Paper menu

Default Source menu

Menu item	Description
Default Source Tray <x> MP Feeder Manual Paper Manual Env	Sets a default paper source for all print jobs Notes: <ul style="list-style-type: none"> • From the Paper menu, Configure MP must be set to Cassette for MP Feeder to appear as a menu setting. • Tray 1 (standard tray) is the factory default setting. • If the same size and type of paper are in two trays and the Paper Size and Paper Type settings match, then the trays are automatically linked. When one tray is empty, the job prints using the linked tray.

Paper Size/Type menu

Menu item	Description
Tray <x> Size A4 A5 JIS B5 Legal Letter Executive Oficio (México) Folio Universal	Specifies the paper size loaded in each tray Notes: <ul style="list-style-type: none"> • Letter is the US factory default setting. A4 is the international factory default setting. • For trays with automatic size sensing, only the size detected by the hardware appears. • If the same size and type of paper are in two trays and the Paper Size and Paper Type settings match, then the trays are automatically linked. When one tray is empty, the job prints using the linked tray.
Note: Only installed trays are listed in this menu.	

Menu item	Description
<p>Tray <x> Type</p> <ul style="list-style-type: none"> Plain Paper Card Stock Transparency Glossy Heavy Glossy Labels Vinyl Labels Bond Letterhead Preprinted Colored Paper Light Paper Heavy Paper Rough/Cotton Recycled Custom Type <x> 	<p>Specifies the type of paper loaded in each tray</p> <p>Notes:</p> <ul style="list-style-type: none"> • Plain Paper is the factory default setting for Tray 1. Custom Type <x> is the factory default setting for all other trays. • If available, a user-defined name will appear instead of Custom Type <x>. • Use this menu item to configure automatic tray linking.
<p>MP Feeder Size</p> <ul style="list-style-type: none"> A4 A5 A6 Executive Oficio (México) Folio JIS B5 Legal Letter Statement Universal 7 3/4 Envelope 9 Envelope 10 Envelope DL Envelope C5 Envelope B5 Envelope Other Envelope 	<p>Specifies the paper size loaded in the multipurpose feeder</p> <p>Notes:</p> <ul style="list-style-type: none"> • From the Paper menu, Configure MP must be set to Cassette for MP Feeder Size to appear as a menu item. • Letter is the US factory default setting. A4 is the international factory default setting.
<p>Note: Only installed trays are listed in this menu.</p>	

Menu item	Description
<p>MP Feeder Type</p> <ul style="list-style-type: none"> Plain Paper Card Stock Transparency Glossy Heavy Glossy Labels Vinyl Labels Bond Envelope Rough Envelope Letterhead Preprinted Colored Paper Light Paper Heavy Paper Rough/Cotton Recycled Custom Type <x> 	<p>Specifies the type of paper loaded in the multipurpose feeder</p> <p>Notes:</p> <ul style="list-style-type: none"> • From the Paper menu, Configure MP must be set to Cassette for MP Feeder Type to appear as a menu item. • Plain paper is the factory default setting.
<p>Manual Paper Size</p> <ul style="list-style-type: none"> A4 A5 A6 JIS B5 Letter Legal Executive Oficio (México) Folio Statement Universal 	<p>Specifies the size of the paper being manually loaded</p> <p>Note: Letter is the US factory default setting. A4 is the international factory default setting.</p>
<p>Note: Only installed trays are listed in this menu.</p>	

Menu item	Description
Manual Paper Type Plain Paper Card Stock Transparency Recycled Glossy Heavy Glossy Labels Vinyl Labels Bond Letterhead Preprinted Colored Paper Light Paper Heavy Paper Roug/Cotton Custom Type <x>	Specifies the type of paper being manually loaded Note: Plain paper is the factory default setting.
Manual Env Size 7 3/4 Envelope 9 Envelope 10 Envelope C5 Envelope B5 Envelope DL Envelope Other Envelope	Specifies the size of the envelope being manually loaded Note: 10 Envelope is the US factory default setting. DL Envelope is the international factory default setting.
Manual Env Type Envelope Rough Envelope Custom Type <x>	Specifies the type of envelope being manually loaded Note: Envelope is the factory default setting.
Note: Only installed trays are listed in this menu.	

Configure MP menu

Menu item	Description
Configure MP Cassette Manual	Determines when the printer selects paper from the multipurpose feeder Notes: <ul style="list-style-type: none"> • Cassette is the factory default setting. • The Cassette setting configures the multipurpose feeder as an automatic paper source. • When Manual is selected, the multipurpose feeder can be used only for manual feed print jobs.

Substitute Size menu

Menu item	Description
Substitute Size Off Statement/A5 Letter/A4 All Listed	Substitutes a specified paper size if the requested paper size is not available Notes: <ul style="list-style-type: none"> • All Listed is the factory default setting. All available substitutions are allowed. • The Off setting indicates no size substitutions are allowed. • Setting a substitution lets the job print without a Change Paper message appearing.

Paper Texture menu

Menu item	Description
Plain Texture Smooth Normal Rough	Specifies the relative texture of the paper loaded Note: Normal is the factory default setting.
Card Stock Texture Smooth Normal Rough	Specifies the relative texture of the card stock loaded Notes: <ul style="list-style-type: none"> • Normal is the factory default setting. • Settings appear only if card stock is supported.
Transparency Texture Smooth Normal Rough	Specifies the relative texture of the transparencies loaded Note: Normal is the factory default setting.
Recycled Texture Smooth Normal Rough	Specifies the relative texture of the recycled paper loaded
Glossy Texture Smooth Normal Rough	Specifies the relative texture of the paper loaded Note: Normal is the factory default setting.
Heavy Glossy Texture Smooth Normal Rough	Specifies the relative texture of the paper loaded Note: Normal is the factory default setting.
Labels Texture Smooth Normal Rough	Specifies the relative texture of the labels loaded Note: Normal is the factory default setting.

Menu item	Description
Vinyl Labels Texture Smooth Normal Rough	Specifies the relative texture of the labels loaded Note: Normal is the factory default setting.
Bond Texture Smooth Normal Rough	Specifies the relative texture of the paper loaded Note: Rough is the factory default setting.
Envelope Texture Smooth Normal Rough	Specifies the relative texture of the envelopes loaded Note: Normal is the factory default setting.
Rough Envelope Texture Smooth Normal Rough	Specifies the relative texture of the envelopes loaded Note: Rough is the factory default setting.
Letterhead Texture Smooth Normal Rough	Specifies the relative texture of the paper loaded Note: Normal is the factory default setting.
Preprinted Texture Smooth Normal Rough	Specifies the relative texture of the paper loaded Note: Normal is the factory default setting.
Colored Texture Smooth Normal Rough	Specifies the relative texture of the paper loaded Note: Normal is the factory default setting.
Light Texture Smooth Normal Rough	Specifies the relative texture of the paper loaded Note: Normal is the factory default setting.
Heavy Texture Smooth Normal Rough	Specifies the relative texture of the paper loaded Note: Normal is the factory default setting.
Rough Texture Smooth Normal Rough	Specifies the relative texture of the paper loaded Note: Rough is the factory default setting.

Menu item	Description
Custom <x> Texture Smooth Normal Rough	Specifies the relative texture of the custom paper loaded Notes: <ul style="list-style-type: none"> • Normal is the factory default setting. • Settings appear only if the custom type is supported.

Paper Weight menu

Menu item	Description
Plain Weight Light Normal Heavy	Specifies the relative weight of the paper loaded Note: Normal is the factory default setting.
Card Stock Weight Light Normal Heavy	Specifies the relative weight of the card stock loaded Notes: <ul style="list-style-type: none"> • Normal is the factory default setting. • Settings appear only if card stock is supported.
Transparency Weight Light Normal Heavy	Specifies the relative weight of the transparencies loaded Note: Normal is the factory default setting.
Recycled Weight Light Normal Heavy	Specifies the relative weight of the recycled paper loaded Note: Normal is the factory default setting.
Glossy Weight Light Normal Heavy	Specifies the relative weight of the glossy paper loaded Note: Normal is the factory default setting.
Heavy Glossy Weight Light Normal Heavy	Specifies the relative weight of the glossy paper loaded Note: Normal is the factory default setting.
Labels Weight Light Normal Heavy	Specifies the relative weight of the labels loaded Note: Normal is the factory default setting.
Vinyl Labels Weight Light Normal Heavy	Specifies the relative weight of the labels loaded Note: Normal is the factory default setting.

Menu item	Description
Bond Weight Light Normal Heavy	Specifies the relative weight of the paper loaded Note: Rough is the factory default setting.
Envelope Weight Light Normal Heavy	Specifies the relative weight of the envelopes loaded Note: Normal is the factory default setting.
Rough Envelope Weight Light Normal Heavy	Specifies the relative weight of the envelopes loaded Note: Normal is the factory default setting.
Letterhead Weight Light Normal Heavy	Specifies the relative weight of the paper loaded Note: Normal is the factory default setting.
Preprinted Weight Light Normal Heavy	Specifies the relative weight of the paper loaded Note: Normal is the factory default setting.
Colored Weight Light Normal Heavy	Specifies the relative weight of the paper loaded Note: Normal is the factory default setting.
Light Weight Light Normal Heavy	Specifies the relative weight of the paper loaded Note: Normal is the factory default setting.
Heavy Weight Light Normal Heavy	Specifies the relative weight of the paper loaded Note: Normal is the factory default setting.
Rough/Cotton Weight Light Normal Heavy	Specifies the relative weight of the paper loaded Note: Normal is the factory default setting.
Custom <x> Weight Light Normal Heavy	Specifies the relative weight of the custom paper loaded Notes: <ul style="list-style-type: none"> • Normal is the factory default setting. • Settings appear only if the custom type is supported.

Paper Loading menu

Menu item	Description
Recycled Loading Duplex Off	Determines the paper loading direction for all jobs that specify Recycled as the paper type Note: Off is the factory default setting.
Glossy Loading Duplex Off	Determines the paper loading direction for all jobs that specify Glossy as the paper type Note: Off is the factory default setting.
Heavy Glossy Loading Duplex Off	Determines the paper loading direction for all jobs that specify Heavy Glossy as the paper type Note: Off is the factory default setting.
Bond Loading Duplex Off	Determines the paper loading direction for all jobs that specify Bond as the paper type Note: Off is the factory default setting.
Letterhead Loading Duplex Off	Determines the paper loading direction for all jobs that specify Letterhead as the paper type Note: Off is the factory default setting.
Preprinted Loading Duplex Off	Determines the paper loading direction for all jobs that specify Preprinted as the paper type Note: Off is the factory default setting.
Colored Loading Duplex Off	Determines the paper loading direction for all jobs that specify Colored as the paper type Note: Off is the factory default setting.
Light Loading Duplex Off	Determines the paper loading direction for all jobs that specify Light as the paper type Note: Off is the factory default setting.
Heavy Loading Duplex Off	Determines the paper loading direction for all jobs that specify Heavy as the paper type Note: Off is the factory default setting.
Custom <x> Loading Duplex Off	Determines the paper loading direction for all jobs that specify Custom <x> as the paper type Notes: <ul style="list-style-type: none"> • Off is the factory default setting. • Custom <x> Loading is available only if the custom type is supported.
Notes: <ul style="list-style-type: none"> • Duplex sets the printer default to 2-sided printing for every print job unless 1-sided printing is selected from Print Properties. • If Duplex is selected, then all print jobs for the selected paper type are sent through the duplex unit, including 1-sided jobs. 	

Custom Types menu

Menu item	Description
Custom Type <x> Paper Card Stock Glossy Transparency Labels Vinyl Labels Envelope	Associates a paper or specialty media type with a Custom Type <x> name or a user-defined Custom Name created from the Embedded Web Server or MarkVision™ Professional Notes: <ul style="list-style-type: none"> • Paper is the factory default setting. • The custom media type must be supported by the selected tray or multipurpose feeder in order to print from that source.
Recycled Paper Card Stock Glossy Transparency Labels Vinyl Labels Envelope	Specifies the recycled paper type loaded in a tray. This will also be the Recycled setting in other menus. Notes: <ul style="list-style-type: none"> • Paper is the factory default setting. • The custom media type must be supported by the selected tray or multipurpose feeder in order to print from that source.

Universal Setup menu

These menu items are used to specify the height and width of the Universal Paper Size. The Universal Paper Size is a user-defined paper size setting. It is listed with the other paper size settings and includes similar options, such as support for duplex printing and printing multiple pages on one sheet.

Menu item	Description
Units of Measure Inches Millimeters	Identifies the units of measure Notes: <ul style="list-style-type: none"> • Inches is the US factory default setting. • Millimeters is the international factory default setting.
Portrait Width 3–8.5 inches 76–216 mm	Sets the portrait width Notes: <ul style="list-style-type: none"> • If the width exceeds the maximum, then the printer uses the maximum width allowed. • 8.5 inches is the US factory default setting. Inches can be increased in 0.01-inch increments. • 216 mm is the international factory default setting. Millimeters can be increased in 1-mm increments.

Menu item	Description
Portrait Height 3–14.17 inches 76–360 mm	Sets the portrait height Notes: <ul style="list-style-type: none"> • If the height exceeds the maximum, then the printer uses the maximum height allowed. • 14 inches is the US factory default setting. Inches can be increased in 0.01-inch increments. • 356 mm is the international factory default setting. Millimeters can be increased in 1-mm increments.
Feed Direction Short Edge Long Edge	Specifies the feed direction Notes: <ul style="list-style-type: none"> • Short Edge is the factory default setting. • Long Edge appears only if the longest edge is shorter than the maximum width supported in the tray.

Reports menu

Reports menu

Menu item	Description
Menu Settings Page	Prints a report containing information about paper loaded into trays, installed memory, the total page count, alarms, timeouts, the printer control panel language, the TCP/IP address, the status of supplies, and the status of the network connection Note: The page prints when this item is selected.
Device Statistics	Prints a report containing printer statistics such as supply information and details about printed pages Note: The page prints when this item is selected.
Network Setup Page	Prints a report containing information about the network printer settings, such as the TCP/IP address information Notes: <ul style="list-style-type: none"> • This menu item appears only for network printers or printers connected to print servers. • The page prints when this item is selected.

Menu item	Description
Network <x> Setup Page	Prints a report containing information about the network printer settings, such as the TCP/IP address information Notes: <ul style="list-style-type: none"> • This selection is available when more than one network option is installed. • This menu item appears only for network printers or printers connected to print servers. • The page prints when this item is selected.
Profiles List	Prints a list of profiles stored in the printer Note: The page prints when this item is selected.
NetWare Setup Page	Prints a report containing NetWare-specific information about the network settings Notes: <ul style="list-style-type: none"> • This menu item appears only for printers with an internal print server installed. • The page prints when this item is selected.
Print Fonts PCL Fonts PostScript Fonts	Prints a report of all the fonts available for the printer language currently set in the printer Note: A separate list is available for PCL and PostScript emulations.
Print Directory	Prints a list of all the resources stored on an optional flash memory card or printer hard disk Notes: <ul style="list-style-type: none"> • Job Buffer Size must be set to 100%. • The optional flash memory or printer hard disk must be installed correctly and working properly. • The page prints when this item is selected.
Asset Report	Prints a report containing each piece of printer asset information, such as the serial number and model name. Note: The page prints when this item is selected.

Network/Ports menu

Active NIC menu

Menu item	Description
Active NIC Auto <list of available network cards>	Notes: <ul style="list-style-type: none"> • Auto is the factory default setting. • This menu item appears only if an optional network card is installed.

Standard Network or Network <x> menus

Note: Only active ports appear in this menu; all inactive ports are omitted.

Menu item	Description
PCL SmartSwitch On Off	Sets the printer to automatically switch to PCL emulation when a print job requires it, regardless of the default printer language Notes: <ul style="list-style-type: none"> • On is the factory default setting. • When the Off setting is used, the printer does not examine incoming data. • When the Off setting is used, the printer uses PostScript emulation if PS SmartSwitch is set to On. It uses the default printer language specified in the Setup menu if PS SmartSwitch is set to Off.
PS SmartSwitch On Off	Sets the printer to automatically switch to PS emulation when a print job requires it, regardless of the default printer language Notes: <ul style="list-style-type: none"> • On is the factory default setting. • When the Off setting is used, the printer does not examine incoming data. • When the Off setting is used, the printer uses PCL emulation if PCL SmartSwitch is set to On. It uses the default printer language specified in the Setup menu if PCL SmartSwitch is set to Off.
NPA Mode Off Auto	Sets the printer to perform the special processing required for bidirectional communication following the conventions defined by the NPA protocol Notes: <ul style="list-style-type: none"> • Auto is the factory default setting. • Changing this setting from the printer control panel and then exiting the menus causes the printer to restart. The menu selection is updated.
Network Buffer Auto 3K to <maximum size allowed>	Sets the size of the network input buffer Notes: <ul style="list-style-type: none"> • Auto is the factory default setting. • The value can be changed in 1-K increments. • The maximum size allowed depends on the amount of memory in the printer, the size of the other link buffers, and whether Resource Save is set to On or Off. • To increase the maximum size range for the Network Buffer, disable or reduce the size of the parallel, serial, and USB buffers. • Changing this setting from the printer control panel and then exiting the menus causes the printer to restart. The menu selection is updated.

Menu item	Description
Job Buffering Off On Auto	Temporarily stores jobs on the printer hard disk before printing. This menu only appears if a formatted disk is installed. Notes: <ul style="list-style-type: none"> • Off is the factory default setting. • The On value buffers jobs on the printer hard disk. This menu selection appears only when a formatted disk is installed and is not defective. • The Auto setting buffers print jobs only if the printer is busy processing data from another input port. • Changing this setting from the printer control panel and then exiting the menus causes the printer to restart. The menu selection is updated.
Mac Binary PS On Off Auto	Sets the printer to process Macintosh binary PostScript print jobs Notes: <ul style="list-style-type: none"> • Auto is the factory default setting. • The Off setting filters print jobs using the standard protocol. • The On setting processes raw binary PostScript print jobs.
Std Network Setup Reports or Network Reports Network Card TCP/IP IPv6 Wireless AppleTalk NetWare LexLink Net <x> Setup Reports or Network Reports Network Card TCP/IP IPv6 Wireless AppleTalk NetWare LexLink	For descriptions and settings of the network setup menus, see the following: <ul style="list-style-type: none"> • “Network Reports menu” on page 91 • “Network Card menu” on page 92 • “TCP/IP menu” on page 92 • “IPv6 menu” on page 94 • “Wireless menu” on page 94 • “AppleTalk menu” on page 95 • “NetWare menu” on page 95 • “LexLink menu” on page 96 Note: The Wireless menu appears only when the printer is connected to a wireless network.

Network Reports menu

This menu is available from the Network/Ports menu:

Network/Ports > Standard Network or Network <x> > Std Network Setup or Net <x> Setup > Reports or Network Reports

Menu item	Description
Print Setup Page	Prints a report containing information about the current network setup
Print NetWare Setup Page	<p>Notes:</p> <ul style="list-style-type: none"> • The Setup Page contains information about the network printer settings, such as the TCP/IP address. • The NetWare Setup Page menu item appears only on models that support NetWare and shows information about NetWare settings.

Network Card menu

This menu is available from the Network/Ports menu:

Network/Ports > Standard Network or Network <x> > Std Network Setup or Net <x> Setup > Network Card

Menu item	Description
View Card Status Connected Disconnected	Lets you view the connection status of the Network Card
View Card Speed	Lets you view the speed of a currently active network card
Network Address UAA LAA	Lets you view the network addresses
Job Timeout 0-225 seconds	<p>Sets the amount of time in seconds that a network print job can take before it is canceled</p> <p>Notes:</p> <ul style="list-style-type: none"> • 90 seconds is the factory default setting. • A setting value of 0 disables the timeout. • If a value of 1–9 is selected, then the setting is saved as 10.
Banner Page Off On	<p>Allows the printer to print a banner page.</p> <p>Note: Off is the factory default setting.</p>

TCP/IP menu

Use the following menu items to view or set the TCP/IP information.

Note: This menu is available only for network models or printers attached to print servers.

This menu is available from the Network/Ports menu:

Network/Ports > Standard Network or Network <x> > Std Network Setup or Net <x> Setup > TCP/IP

Menu item	Description
Activate On Off	Activates TCP/IP Note: On is the factory default setting.
View Hostname	Lets you view the current TCP/IP hostname Note: This can be changed only from the Embedded Web Server.
IP Address	Lets you view or change the current TCP/IP Address Note: Manually setting the IP address sets the Enable DHCP and Enable Auto IP settings to Off. It also sets Enable BOOTP and Enable RARP to Off on systems that support BOOTP and RARP.
Netmask	Lets you view or change the current TCP/IP Netmask
Gateway	Lets you view or change the current TCP/IP Gateway
Enable DHCP On Off	Specifies the DHCP address and parameter assignment setting Note: On is the factory default setting.
Enable RARP On Off	Specifies the RARP address assignment setting Note: On is the factory default setting.
Enable BOOTP On Off	Specifies the BOOTP address assignment setting Note: On is the factory default setting.
Enable Auto IP Yes No	Specifies the Zero Configuration Networking setting Note: Yes is the factory default setting.
Enable FTP/TFTP Yes No	Enables the built-in FTP server, which allows you to send files to the printer using the File Transfer Protocol. Note: Yes is the factory default setting.
Enable HTTP Server Yes No	Enables the built-in Web server (Embedded Web Server). When this is enabled, the printer can be monitored and managed remotely using a Web browser. Note: Yes is the factory default setting.
WINS Server Address	Lets you view or change the current WINS Server Address
Enable DDNS Yes No	Lets you view or change the current DDNS setting Note: Yes is the factory default setting.
Enable mDNS Yes No	Lets you view or change the current mDNS setting Note: Yes is the factory default setting.
DNS Server Address	Lets you view or change the current DNS Server Address
Enable HTTPS Yes No	Lets you view or change the current HTTPS setting Note: Yes is the factory default setting.

IPv6 menu

Use the following menu items to view or set the Internet Protocol version 6 (IPv6) information.

Note: This menu is available only for network models or printers attached to print servers.

This menu is available from the Network/Ports menu:

Network/Ports > Standard Network or Network <x> > Std Network Setup or Net <x> Setup > IPv6

Menu item	Description
Enable IPv6 On Off	Enables IPv6 in the printer Note: On is the factory default setting.
Auto Configuration On Off	Specifies whether the network adapter accepts the automatic IPv6 address configuration entries provided by a router Note: On is the factory default setting.
View Hostname View Address View Router Address	Lets you view the current setting Note: These settings can be changed only from the Embedded Web Server.
Enable DHCPv6 On Off	Enables DHCPv6 in the printer Note: On is the factory default setting.

Wireless menu

Use the following menu items to view or configure the wireless internal print server settings.

Note: This menu is available only for models connected to a wireless network.

This menu is available from the Network/Ports menu:

Network/Ports > Network <x> > Net <x> Setup > Wireless

Menu item	Description
Network Mode Infrastructure Ad hoc	Specifies the network mode Notes: <ul style="list-style-type: none"> • Infrastructure mode lets the printer access a network using an access point. • Ad hoc is the factory default setting. Ad hoc mode configures the printer for wireless networking directly between it and a computer.
Compatibility 802.11n 802.11b/g 802.11b/g/n	Specifies the wireless standard for the wireless network
Choose Network <list of available networks>	Lets you select an available network for the printer to use

Menu item	Description
View Signal Quality	Lets you view the quality of the wireless connection
View Security Mode	Lets you view the encryption method for the wireless connection. "Disabled" indicates that the wireless network is not encrypted.

AppleTalk menu

This menu is available from the Network/Ports menu:

Network/Ports > Standard Network or Network <x> > Std Network Setup or Net <x> Setup > AppleTalk

Menu item	Description
Activate Yes No	Activates AppleTalk support Note: Yes is the factory default setting.
View Name	Shows the assigned AppleTalk name Note: The name can be changed only from the Embedded Web Server.
View Address	Shows the assigned AppleTalk address Note: The address can be changed only from the Embedded Web Server.
Set Zone <list of zones available on the network>	Provides a list of AppleTalk zones available on the network Note: The default setting is the default zone for the network. If no default zone exists, the zone marked with an * is the default setting.

NetWare menu

This menu is available from the Network/Ports menu:

Network/Ports > Standard Network or Network <x> > Std Network Setup or Net <x> Setup > NetWare

Menu item	Description
Activate Yes No	Activates NetWare support Note: No is the factory default setting.
View Login Name	Lets you view the assigned NetWare login name Note: This can be changed only from the Embedded Web Server.
Print Mode	Lets you view the assigned NetWare print mode Note: This can be changed only from the Embedded Web Server.
Network Number	Lets you view the assigned NetWare network number Note: This can be changed only from the Embedded Web Server.

Menu item	Description
Select SAP Frames Ethernet 802.2 Ethernet 802.3 Ethernet Type II Ethernet SNAP	Enables the Ethernet frame type setting Note: On is the factory default setting for all menu items.
Packet Burst Yes No	Reduces network traffic by allowing the transfer and acknowledgement of multiple data packets to and from the NetWare server Note: Yes is the factory default setting.
NSQ/GSQ Mode Yes No	Specifies the NSQ/GSQ Mode setting Note: Yes is the factory default setting.

LexLink menu

This menu is available from the Network/Ports menu:

Network/Ports > Standard Network or Network <x> > Std Network Setup or Net <x> Setup > LexLink menu

Menu item	Description
Activate On Off	Activates LexLink support Note: Off is the factory default setting.
View Nickname	Lets you view the assigned LexLink nickname Note: The LexLink nickname can be changed only from the Embedded Web Server.

Standard USB menus

Menu item	Description
PCL SmartSwitch On Off	Sets the printer to automatically switch to PCL emulation when a print job received through a USB port requires it, regardless of the default printer language Notes: <ul style="list-style-type: none"> • On is the factory default setting. • When the Off setting is used, the printer does not examine incoming data. • When the Off setting is used, the printer uses PostScript emulation if the PS Smartswitch setting is On. It uses the default printer language specified in the Setup menu if the PS SmartSwitch setting is Off.

Menu item	Description
PS SmartSwitch On Off	Sets the printer to automatically switch to PS emulation when a print job received through a USB port requires it, regardless of the default printer language Notes: <ul style="list-style-type: none"> • On is the factory default setting. • When the Off setting is used, the printer does not examine incoming data. • When the Off setting is used, the printer uses PCL emulation if the PCL Smartswitch setting is On. It uses the default printer language specified in the Setup menu if the PCL SmartSwitch setting is Off.
NPA Mode On Off Auto	Sets the printer to perform the special processing required for bidirectional communication following the conventions defined by the NPA protocol Notes: <ul style="list-style-type: none"> • Auto is the factory default setting. • Changing this setting from the printer control panel and then exiting the menus causes the printer to restart. The menu selection is updated.
USB Buffer Disabled Auto 3k to <maximum size allowed>	Sets the size of the USB input buffer Notes: <ul style="list-style-type: none"> • Auto is the factory default setting. • The Disabled setting turns off job buffering. Any jobs already buffered on the disk are printed before normal processing is resumed. • The USB buffer size value can be changed in 1-k increments. • The maximum size allowed depends on the amount of memory in the printer, the size of the other link buffers, and whether the Resource Save setting is On or Off. • To increase the maximum size range for the USB Buffer, disable or reduce the size of the parallel, serial, and network buffers. • Changing this setting from the printer control panel and then exiting the menus causes the printer to restart. The menu selection is updated.
Job Buffering Off On Auto	Temporarily stores jobs on the printer hard disk before printing Notes: <ul style="list-style-type: none"> • Off is the factory default setting. • The On setting buffers jobs on the printer hard disk. • The Auto setting buffers print jobs only if the printer is busy processing data from another input port. • Changing this setting from the printer control panel and then exiting the menus causes the printer to restart. The menu selection is updated.
Mac Binary PS On Off Auto	Sets the printer to process Macintosh binary PostScript print jobs Notes: <ul style="list-style-type: none"> • Auto is the factory default setting. • The Off setting filters print jobs using the standard protocol. • The On setting processes raw binary PostScript print jobs.

Menu item	Description
ENA Address	Sets the network address information for an external print server that is attached to the printer using a USB cable Note: This menu item is available only if the printer is attached to an external print server through the USB port.
ENA Netmask	Sets the netmask information for an external print server that is attached to the printer using a USB cable Note: This menu item is available only if the printer is attached to an external print server through the USB port.
ENA Gateway	Sets the gateway information for an external print server that is attached to the printer using a USB cable Note: This menu item is available only if the printer is attached to an external print server through the USB port.

Parallel <x> menu

Menu item	Description
PCL SmartSwitch On Off	Sets the printer to automatically switch to PCL emulation when a print job received through a serial port requires it, regardless of the default printer language Notes: <ul style="list-style-type: none"> • On is the factory default setting. • When the Off setting is used, the printer does not examine incoming data. • When the Off setting is used, the printer uses PostScript emulation if PS SmartSwitch is set to On. It uses the default printer language specified in the Setup menu if PS SmartSwitch is set to Off.
PS SmartSwitch On Off	Sets the printer to automatically switch to PS emulation when a print job received through a serial port requires it, regardless of the default printer language Notes: <ul style="list-style-type: none"> • On is the factory default setting. • When the Off setting is used, the printer does not examine incoming data. • When the Off setting is used, the printer uses PCL emulation if PCL SmartSwitch is set to On. It uses the default printer language specified in the Setup menu if PCL SmartSwitch is set to Off.
NPA Mode On Off Auto	Sets the printer to perform the special processing required for bidirectional communication following the conventions defined by the NPA protocol Notes: <ul style="list-style-type: none"> • Auto is the factory default setting. • Changing this setting from the printer control panel and then exiting the menus causes the printer to restart. The menu selection is updated.

Menu item	Description
Parallel Buffer Disabled Auto 3k to <maximum size allowed>	Sets the size of the parallel input buffer Notes: <ul style="list-style-type: none"> • Auto is the factory default setting. • The Disabled setting turns off job buffering. Any jobs already buffered on the disk are printed before normal processing is resumed. • The parallel buffer size setting can be changed in 1k increments. • The maximum size allowed depends on the amount of memory in the printer, the size of the other link buffers, and whether Resource Save is set to On or Off. • To increase the maximum size range for the Parallel Buffer, disable or reduce the size of the USB, serial, and network buffers. • Changing this setting from the printer control panel and then exiting the menus causes the printer to restart. The menu selection is updated.
Job Buffering Off On Auto	Temporarily stores jobs on the printer hard disk before printing Notes: <ul style="list-style-type: none"> • Off is the factory default setting. • The Off setting does not buffer print jobs to the printer hard disk. • The On setting buffers jobs on the printer hard disk. • The Auto setting buffers print jobs only if the printer is busy processing data from another input port. • Changing this setting from the printer control panel and then exiting the menus causes the printer to restart. The menu selection is updated.
Advanced Status On Off	Enables bidirectional communication through the parallel port Notes: <ul style="list-style-type: none"> • On is the factory default setting. • The Off setting disables parallel port negotiation.
Parallel Protocol Standard Fastbytes	Specifies the parallel port protocol Notes: <ul style="list-style-type: none"> • Fastbytes is the factory default setting. It provides compatibility with most existing parallel ports and is the recommended setting. • The Standard setting tries to resolve parallel port communication problems.
Honor Init On Off	Determines whether or not the printer honors printer hardware initialization requests from the computer Notes: <ul style="list-style-type: none"> • Off is the factory default setting. • The computer requests initialization by activating the Init signal from the parallel port. Many personal computers activate the Init signal each time the computer is turned on.

Menu item	Description
Parallel Mode 2 On Off	Determines whether or not the parallel port data is sampled on the leading or trailing edge of strobe Note: On is the factory default setting.
Mac Binary PS On Off Auto	Sets the printer to process Macintosh binary PostScript print jobs Notes: <ul style="list-style-type: none"> • Auto is the factory default setting. • The Off setting filters print jobs using the standard protocol. • The On setting processes raw binary PostScript print jobs.
ENA Address <xxx>.<xxx>.<xxx>.<xxx>	Sets the network address information for an external print server that is attached to the printer using a USB cable Note: This menu item is available only if the printer is attached to an external print server through the USB port.
ENA Netmask <xxx>.<xxx>.<xxx>.<xxx>	Sets the netmask information for an external print server that is attached to the printer using a USB cable Note: This menu item is available only if the printer is attached to an external print server through the USB port.
ENA gateway <xxx>.<xxx>.<xxx>.<xxx>	Sets the gateway information for an external print server that is attached to the printer using a USB cable Note: This menu item is available only if the printer is attached to an external print server through the USB port.

Serial <x> menu

Menu item	Description
PCL SmartSwitch On Off	Sets the printer to automatically switch to PCL emulation when a print job received through a serial port requires it, regardless of the default printer language Notes: <ul style="list-style-type: none"> • On is the factory default setting. • When the Off setting is used, the printer does not examine incoming data. • When the Off setting is used, the printer uses PostScript emulation if PS SmartSwitch is set to On. It uses the default printer language specified in the Setup menu if PS SmartSwitch is set to Off.
PS SmartSwitch On Off	Sets the printer to automatically switch to PS emulation when a print job received through a serial port requires it, regardless of the default printer language Notes: <ul style="list-style-type: none"> • On is the factory default setting. • When the Off setting is used, the printer does not examine incoming data. • When the Off setting is used, the printer uses PCL emulation if PCL SmartSwitch is set to On. It uses the default printer language specified in the Setup menu if PCL SmartSwitch is set to Off.

Menu item	Description
NPA Mode On Off Auto	Sets the printer to perform the special processing required for bidirectional communication following the conventions defined by the NPA protocol Notes: <ul style="list-style-type: none"> • Auto is the factory default setting. • When the On setting is used, the printer performs NPA processing. If the data is not in NPA format, it is rejected as bad data. • When the Off setting is used, the printer does not perform NPA processing. • When the Auto setting is used, the printer examines data, determines the format, and then processes it appropriately. • Changing this setting from the control panel and then exiting the menus causes the printer to restart. The menu selection is updated.
Serial Buffer Disabled Auto 3k to <maximum size allowed>	Sets the size of the serial input buffer Notes: <ul style="list-style-type: none"> • Auto is the factory default setting. • The Disabled setting turns off job buffering. Any jobs already buffered on the disk are printed before normal processing is resumed. • The serial buffer size setting can be changed in 1k increments. • The maximum size allowed depends on the amount of memory in the printer, the size of the other link buffers, and whether Resource Save is set to On or Off. • To increase the maximum size range for the Serial Buffer, disable or reduce the size of the parallel, serial, and network buffers. • Changing this setting from the control panel and then exiting the menus causes the printer to restart. The menu selection is updated.
Job Buffering Off On Auto	Temporarily stores jobs on the printer hard disk before printing Notes: <ul style="list-style-type: none"> • Off is the factory default setting. • The Off setting does not buffer print jobs to the hard disk. • The On setting buffers jobs on the printer hard disk. • The Auto setting buffers print jobs only if the printer is busy processing data from another input port. • Changing this setting from the control panel and then exiting the menus causes the printer to restart. The menu selection is updated.
Serial Protocol DTR DTR/DSR XON/XOFF XON/XOFF/DTR XONXOFF/DTRDSR	Selects the hardware and software handshaking settings for the serial port Notes: <ul style="list-style-type: none"> • DTR is the factory default setting. • DTR/DSR is a hardware handshaking setting. • XON/XOFF is a software handshaking setting. • XON/XOFF/DTR and XON/XOFF/DTR/DSR are combined hardware and software handshaking settings.

Menu item	Description
Robust XON On Off	Determines whether or not the printer communicates availability to the computer Notes: <ul style="list-style-type: none"> Off is the factory default setting. This menu item applies only to the serial port if Serial Protocol is set to XON/XOFF.
Baud 1200 2400 4800 9600 19200 38400 57600 115200 138200 172800 230400 345600	Specifies the rate at which data can be received through the serial port Notes: <ul style="list-style-type: none"> 9600 is the factory default setting. 138200, 172800, 230400, and 345600 baud rates are only displayed in the Standard Serial menu. These settings do not appear in the Serial Option 1, Serial Option 2, or Serial Option 3 menus.
Data Bits 7 8	Specifies the number of data bits that are sent in each transmission frame Note: 8 is the factory default setting.
Parity Even Odd None Ignore	Sets the parity for serial input and output data frames Note: None is the factory default setting.
Honor DSR On Off	Determines whether the printer uses the DSR Signal. DSR is a handshaking signal used by most serial cables. Notes: <ul style="list-style-type: none"> Off is the factory default setting. The serial port uses DSR to distinguish data sent by the computer from data created by electrical noise in the serial cable. The electrical noise can cause stray characters to print. Select On to prevent stray characters from printing.

SMTP Setup menu

Use the following menu to configure the SMTP server.

Menu item	Description
Primary SMTP Gateway Primary SMTP Gateway Port Secondary SMTP Gateway Secondary SMTP Gateway Port	Specifies SMTP server port information Note: 25 is the default SMTP gateway port. Range is 1-65536.
SMTP Timeout 5–30	Specifies the amount of time in seconds before the server stops trying to send the e-mail Note: 30 seconds is the factory default setting.
Reply Address	Specifies a reply address of up to 128 characters in e-mail sent by the printer
Use SSL Disabled Negotiate Required	Sets the printer to use SSL for increased security when connecting to the SMTP server Notes: <ul style="list-style-type: none"> • Disabled is the factory default setting for Use SSL. • When the Negotiate setting is used, your SMTP server determines if SSL will be used.
SMTP Server Authentication No authentication required Login/Plain CRAM-MD5 Digest-MD5 NTLM Kerberos 5	Specifies the type of user authentication required Note: “No authentication required” is the factory default setting.
Device-Initiated E-mail None Use Device SMTP Credentials Device Userid Device Password Kerberos 5 Realm NTLM Domain	Specifies what credentials will be used when communicating to the SMTP server. Some SMTP servers require credentials in order to send e-mail. Notes: <ul style="list-style-type: none"> • None is the factory default setting for Device-Initiated E-mail. • Device Userid and Device Password are used to log in to the SMTP server when "Use Device SMTP Credentials" is selected.

Security menu

Miscellaneous menu

Menu item	Description
Login Restriction Login failures 1-10 (3 attempts) Failure time frame 1-60 (5 minutes) Lockout time 1-60 (5 minutes) Panel Login Timeout 1-900 (3 seconds) Remote Login Timeout 1-120 (10 minutes)	Limits the number and time frames of failed login attempts from the printer control panel before <i>all</i> users are locked out Notes: <ul style="list-style-type: none"> • “Login failures” specifies the number of failed login attempts before users are locked out. 3 attempts is the factory default setting. • “Failure time frame” specifies the time frame during which failed login attempts can be made before users are locked out. 5 minutes is the factory default setting. • “Lockout time” specifies how long users are locked out after exceeding the login failures limit. 5 minutes is the factory default setting. • “Panel Login Timeout” specifies how long the printer remains idle on the Home screen before automatically logging the user off. 3 seconds is the factory default setting. • “Remote Login Timeout” specifies how long a remote interface (for example, the Web page) can remain idle before automatically logging the user off. 10 minutes is the factory default setting.
Enable Drive Enable Disable	Enables or disables support for the front USB port Note: Enable is the factory default setting.

Confidential Print menu

Menu item	Description
Max Invalid PIN Off 2–10	Limits the number of times an invalid PIN can be entered Notes: <ul style="list-style-type: none"> • Off is the default setting. • This menu item appears only if a printer hard disk is installed. • Once a limit is reached, the jobs for that user name and that PIN are deleted.
Job Expiration Off 1 hour 4 hours 24 hours 1 week	Limits the amount of time a confidential job stays in the printer before it is deleted Notes: <ul style="list-style-type: none"> • Off is the default setting. • If the Job Expiration setting is changed while confidential jobs reside on the printer RAM or printer hard disk, the expiration time for those print jobs does not change to the new default value. • If the printer is turned off, all confidential jobs held in printer RAM are deleted.

Disk Wiping menu

Menu item	Description
Wiping Mode Off Auto Manual	<p>Disk Wiping erases <i>only</i> print job data that <i>is not</i> currently in use by the file system from the printer hard disk. All permanent data on the printer hard disk is preserved, such as downloaded fonts, macros, and held jobs.</p> <p>Notes:</p> <ul style="list-style-type: none"> • This menu item appears only if a formatted, non-defective printer hard disk is installed. • Off is the factory default setting. • Due to the large amount of resources required for Automatic Wiping, activating this option may decrease printer performance, especially if the printer requires hard disk space faster than it can be wiped and returned to service.
Manual Wiping Start now Do not start now	<p>Disk Wiping erases <i>only</i> print job data that <i>is not</i> currently in use by the file system from the printer hard disk. All permanent data on the printer hard disk is preserved, such as downloaded fonts, macros, and held jobs.</p> <p>Manual Wiping overwrites all disk space that has been used to hold data from a print job that has been processed (printed). This type of wipe <i>does not</i> erase any information related to an unprocessed print job.</p> <p>Notes:</p> <ul style="list-style-type: none"> • This menu item appears only if a formatted, non-defective printer hard disk is installed. • "Do not start now" is the factory default setting. • If the Disk Wiping access control is activated, then a user must successfully authenticate and have the required authorization in order to initiate the disk wipe.
Automatic Method Single pass Multiple pass	<p>Disk Wiping erases <i>only</i> print job data that <i>is not</i> currently in use by the file system from the printer hard disk. All permanent data on the printer hard disk is preserved, such as downloaded fonts, macros, and held jobs.</p> <p>Notes:</p> <ul style="list-style-type: none"> • This menu item appears only if a formatted, non-defective printer hard disk is installed. • Single pass is the factory default setting. • Highly confidential information should be wiped using the Multiple pass method <i>only</i>.

Menu item	Description
Manual Method Single pass Multiple pass	<p>Disk Wiping erases <i>only</i> print job data that <i>is not</i> currently in use by the file system from the printer hard disk. All permanent data on the printer hard disk is preserved, such as downloaded fonts, macros, and held jobs.</p> <p>Both manual and scheduled wiping allow the file system to reuse marked disk space without first having to wipe it.</p> <p>Notes:</p> <ul style="list-style-type: none"> • This menu item appears only if a formatted, non-defective printer hard disk is installed. • Single pass is the factory default setting. • Highly confidential information should be wiped using the Multiple Pass method <i>only</i>.
Scheduled Method Single pass Multiple pass	<p>Disk Wiping erases <i>only</i> print job data that <i>is not</i> currently in use by the file system from the printer hard disk. All permanent data on the printer hard disk is preserved, such as downloaded fonts, macros, and held jobs.</p> <p>Both manual and scheduled wiping allow the file system to reuse marked disk space without first having to wipe it.</p> <p>Notes:</p> <ul style="list-style-type: none"> • This menu item appears only if a formatted, non-defective printer hard disk is installed. • Single pass is the factory default setting. • Highly confidential information should be wiped using the Multiple Pass method <i>only</i>. • Scheduled wipes are initiated <i>without</i> displaying a user warning or confirmation message.

Security Audit Log menu

Menu item	Description
Export Log	<p>Enables an authorized user to export the security log</p> <p>Notes:</p> <ul style="list-style-type: none"> • To export the log from the printer control panel, a flash drive must be attached to the printer. • From the Embedded Web Server, the log can be downloaded to a computer.
Delete Log Delete now Do not delete	<p>Specifies whether audit logs are deleted</p> <p>Note: Delete Now is the factory default setting.</p>

Menu item	Description
Configure Log Enable Audit Yes No Enable Remote Syslog Yes No Remote Syslog Facility 0-23 Severity of events to log 0-7	Specifies whether and how the audit logs are created Notes: <ul style="list-style-type: none"> • Enable audit determines if events are recorded in the secure audit log and remote syslog. No is the factory default setting. • Enable remote syslog determines if logs are being sent to a remote server. No is the factory default setting. • Remote syslog facility determines the value used to send logs to the remote syslog server. 4 is the factory default setting. • With the security audit log activated, the severity value of each event is recorded. 4 is the factory default setting.

Set Date/Time menu

Menu item	Description
View Date/Time	Lets you view the current date and time settings for the printer
Set Date/Time <input date/time>	Note: Date/Time is set in YYYY-MM-DD HH:MM format.
Time Zone <list of time zones>	Note: GMT is the factory default setting.
Observe DST On Off	Note: On is the factory default setting and uses the applicable Daylight Saving Time associated with the Time Zone setting.
Enable NTP On Off	Enables Network Time Protocol, which synchronizes the clocks of devices on a network Note: On is the factory default setting.

Settings menu

General Settings menu

Menu item	Description
<p>Display Language</p> <ul style="list-style-type: none"> English Francais Deutsch Italiano Espanol Dansk Norsk Nederlands Svenska Portuguese Suomi Russian Polski Magyar Turkce Cesky Simplified Chinese Traditional Chinese Korean Japanese 	<p>Sets the language of the text appearing on the display</p> <p>Note: All languages may not be available for all printers.</p>
<p>Eco-Mode</p> <ul style="list-style-type: none"> Off Energy Energy/Paper Paper 	<p>Minimizes the use of energy, paper, or specialty media</p> <p>Notes:</p> <ul style="list-style-type: none"> • Off is the factory default setting. Off resets the printer to its factory default settings. • The Energy setting minimizes the power used by the printer. Performance may be affected, but print quality is not. • Paper minimizes the amount of paper and specialty media needed for a print job. Performance may be affected, but print quality is not. • Energy/Paper minimizes the use of power and of paper and specialty media.

Menu item	Description
Quiet Mode Off (Image/Photo) On (Text/Graphics)	Reduces the amount of noise produced by the printer Notes: <ul style="list-style-type: none"> • Off is the factory default setting. This setting supports the performance specifications for your printer. • On configures the printer to produce as little noise as possible. This setting is best suited for printing text and line graphics. • For optimal printing of color-rich documents, set Quiet Mode to Off. • Selecting Photo from the driver may disable Quiet Mode and provide better print quality and full speed printing.
Run Initial Setup Yes No	Instructs the printer to run the setup wizard Notes: <ul style="list-style-type: none"> • Yes is the factory default setting. • After completing the setup wizard by selecting Done at the Country select screen, the default becomes No.
Paper Sizes US Metric	Notes: <ul style="list-style-type: none"> • The initial setting is determined by your Country selection in the initial setup wizard. • Changing this setting also changes the Units of Measurement setting in the Universal Setup menu and the default for each input source in the Paper Size/Type menu.
Alarms Alarm Control Cartridge Alarm	Sets an alarm to sound when the printer requires operator intervention Available selections for each alarm type are: Off Single Continuous Notes: <ul style="list-style-type: none"> • Single is the factory default setting for Alarm Control. Single sounds three quick beeps. • Off is the factory default setting for Cartridge Alarm. Off means no alarm will sound. • Continuous repeats three beeps every 10 seconds.

Menu item	Description
Timeouts Power Saver 1–240	Sets the amount of time the printer waits after a job is printed before it goes into a reduced power state Notes: <ul style="list-style-type: none"> • 30 minutes is the factory default setting. • Lower settings conserve more energy, but may require longer warm-up times. • Select the lowest setting if the printer shares an electrical circuit with room lighting or you notice lights flickering in the room. • Select a high setting if the printer is in constant use. Under most circumstances, this keeps the printer ready to print with minimum warm-up time.
Timeouts Screen Timeout 15–300	Sets the amount of time in seconds the printer waits before returning the printer display to a Ready state Note: 30 seconds is the factory default setting.
Timeouts Print Timeout Disabled 1–255	Sets the amount of time in seconds the printer waits to receive an end-of-job message before canceling the remainder of the print job Notes: <ul style="list-style-type: none"> • 90 seconds is the factory default setting. • When the timer expires, any partially printed page still in the printer is printed, and then the printer checks to see if any new print jobs are waiting. • Print Timeout is available only when using PCL emulation. This setting has no effect on PostScript emulation print jobs.
Timeouts Wait Timeout Disabled 15–6553515	Sets the amount of time in seconds the printer waits for additional data before canceling a print job Notes: <ul style="list-style-type: none"> • 40 seconds is the factory default setting. • Wait Timeout is available only when the printer is using PostScript emulation. This setting has no effect on PCL emulation print jobs.
Timeouts Job Hold Timeout 5–255	Sets the amount of time the printer waits for user intervention before it holds jobs that require unavailable resources and continues to print other jobs in the print queue Notes: <ul style="list-style-type: none"> • 30 seconds is the factory default setting. • This menu item appears only when a hard disk is installed.
Print Recovery Auto Continue Disabled 5–255	Lets the printer automatically continue printing from certain offline situations when not resolved within the specified time period Note: Disabled is the factory default setting.

Menu item	Description
Print Recovery Jam Recovery On Off Auto	Specifies whether the printer reprints jammed pages Notes: <ul style="list-style-type: none"> • Auto is the factory default setting. The printer reprints jammed pages unless the memory required to hold the pages is needed for other printer tasks. • On sets the printer to always reprint jammed pages. • Off sets the printer to never reprint jammed pages.
Print Recovery Page Protect Off On	Lets the printer successfully print a page that may not have printed otherwise Notes: <ul style="list-style-type: none"> • Off is the factory default setting. Off prints a partial page when there is not enough memory to print the whole page. • On sets the printer to process the whole page so that the entire page prints.
Factory Defaults Do Not Restore Restore Now	Returns the printer settings to the factory default settings Notes: <ul style="list-style-type: none"> • Do Not Restore is the factory default setting. Do Not Restore keeps the user-defined settings. • Restore Now returns all printer settings to the factory default settings except Network/Ports menu settings. All downloads stored in RAM are deleted. Downloads stored in flash memory or on a printer hard disk are not affected.
Custom Home Message Off IP Address Hostname Contact Name Location Zero Configuration Name Custom Text 1	Displays information pertaining to the selected Custom Home Messages on the printer control panel display

Setup menu

Menu item	Description
Printer Language PCL Emulation PS Emulation	Sets the default printer language Notes: <ul style="list-style-type: none"> • PCL emulation uses a PCL interpreter for processing print jobs. PostScript emulation uses a PS interpreter for processing print jobs. • PCL is the factory default printer language. • Setting a printer language as the default does not prevent a software program from sending print jobs that use another printer language.
Job Waiting On Off	Specifies that print jobs be removed from the print queue if they require unavailable printer options or custom settings. They are stored in a separate print queue, so other jobs print normally. When the missing information and/or options are obtained, the stored jobs print. Notes: <ul style="list-style-type: none"> • Off is the factory default setting. • This menu appears only if a non-Read Only printer hard disk is installed. This requirement ensures that stored jobs are not deleted if the printer loses power.
Print Area Normal Whole Page	Sets the logical and physical printable area Notes: <ul style="list-style-type: none"> • Normal is the factory default setting. When attempting to print data in the non-printable area defined by the Normal setting, the printer clips the image at the boundary. • The Whole Page setting allows the image to be moved into the non-printable area defined by the Normal setting, but the printer will clip the image at the Normal setting boundary. • The Whole Page setting affects only pages printed using a PCL 5e interpreter. This setting has no effect on pages printed using the PCL XL or PostScript interpreter.
Printer Usage Max Yield Max Speed	Sets the printer for a faster print speed or a higher toner yield. Note: Max Yield is the factory default setting.
Black Only Mode Off On	Sets the printer to print text and graphics using only the black toner cartridge. Note: Off is the factory default setting.

Menu item	Description
<p>Download Target</p> <p>RAM Flash Disk</p>	<p>Sets the storage location for downloads</p> <p>Notes:</p> <ul style="list-style-type: none"> • RAM is the factory default setting. • Storing downloads in flash memory or on a printer hard disk places them in permanent storage. Downloads remain in flash memory or on the printer hard disk even when the printer is turned off. • Storing downloads in RAM is temporary. • This menu appears only if a flash and/or disk option is installed.
<p>Job Accounting</p> <p>Off On</p>	<p>Specifies whether the printer stores statistical information about the most recent print jobs on the hard disk</p> <p>Notes:</p> <ul style="list-style-type: none"> • Off is the factory default setting. Off means the printer does not store job statistics. • The statistics include a record of print errors, the print time, the job size in bytes, the requested paper size and type, the total number of printed pages, and the total number of copies requested. • Job Accounting is available only when a printer hard disk is installed and working properly. It should not be Read/Write or Write protected. Job Buffer Size should not be set to 100%. • Changing this setting from the printer control panel and then exiting the menus causes the printer to reset. The menu selection is updated.
<p>Resource Save</p> <p>On Off</p>	<p>Specifies how the printer handles temporary downloads, such as fonts and macros stored in RAM, when the printer receives a job that requires more memory than is available</p> <p>Notes:</p> <ul style="list-style-type: none"> • Off is the factory default setting. Off sets the printer to retain the downloads only until memory is needed. Downloads are deleted in order to process print jobs. • The On setting retains the downloads during language changes and printer resets. If the printer runs out of memory, 38 Memory Full appears, and downloads are not deleted.
<p>Print All Order</p> <p>Alphabetical Oldest First Newest First</p>	<p>Specifies the order in which held and confidential jobs are printed when Print All is selected</p> <p>Notes:</p> <ul style="list-style-type: none"> • Alphabetical is the factory default setting. • Print jobs always appear in alphabetical order on the printer control panel.

Finishing menu

Menu item	Description
Sides (Duplex) 1 sided 2 sided	Specifies whether duplex (2-sided) printing is set as the default for all print jobs Notes: <ul style="list-style-type: none"> • 1 sided is the factory default setting. • To set 2-sided printing from the software program: for Windows users, click File > Print, and then click Properties, Preferences, Options, or Setup; for Macintosh users, choose File > Print, and then adjust the settings from the print dialog and pop-up menus.
Duplex Binding Long Edge Short Edge	Defines the way duplexed pages are bound and how the printing on the back of the page is oriented in relation to the printing on the front of the page Notes: <ul style="list-style-type: none"> • Long Edge is the factory default setting. • Long Edge specifies that binding be placed on the left edge of portrait pages and the top edge of landscape pages. • Short Edge specifies that binding be placed on the top edge of portrait pages and the left edge of landscape pages.
Copies 1–999	Specifies a default number of copies for each print job Note: 1 is the factory default setting.
Blank Pages Do Not Print Print	Specifies whether blank pages are inserted in a print job Note: Do Not Print is the factory default setting.
Collate Off (1,1,1,2,2,2) On (1,2,1,2,1,2)	Stacks the pages of a print job in sequence when printing multiple copies Notes: <ul style="list-style-type: none"> • Off is the factory default setting. No pages will be collated. • The On setting stacks the print job sequentially. • Both settings print the entire job the number of times specified by the Copies menu setting.
Separator Sheets None Between Copies Between Jobs Between Pages	Specifies whether blank separator sheets are inserted Notes: <ul style="list-style-type: none"> • None is the factory default setting. • Between Copies inserts a blank sheet between each copy of a print job if Collation is set to On. If Collation is set to Off, a blank page is inserted between each set of printed pages, such as after all page 1's and after all page 2's. • Between Jobs inserts a blank sheet between print jobs. • Between Pages inserts a blank sheet between each page of the print job. This setting is useful when printing transparencies or inserting blank pages in a document for notes.

Menu item	Description
Separator Source Tray <x> Multi-Purpose Feeder	Specifies the paper source for separator sheets Notes: <ul style="list-style-type: none"> • Tray 1 (standard tray) is the factory default setting. • From the Paper menu, Configure MP must be set to Cassette for Multi-Purpose Feeder to appear as a menu setting.
N-up (pages-side) Off 2-Up 3-Up 4-Up 6-Up 9-Up 12-Up 16-Up	Specifies that multiple-page images be printed on one side of a sheet of paper. Notes: <ul style="list-style-type: none"> • Off is the factory default setting. • The number selected is the number of page images that will print per side.
N-up Ordering Horizontal Reverse Horizontal Reverse Vertical Vertical	Specifies the positioning of multiple-page images when using N-up (pages-sides) Notes: <ul style="list-style-type: none"> • Horizontal is the factory default setting. • Positioning depends on the number of images and whether the images are in portrait or landscape orientation.
Orientation Auto Landscape Portrait	Specifies the orientation of a multiple-page sheet Note: Auto is the factory default setting. The printer chooses between portrait and landscape.
N-up Border None Solid	Prints a border around each page image when using N-up (pages-sides) Note: None is the factory default setting.

Quality menu

Menu item	Description
Print Mode Color Black Only	Specifies whether images are printed in monochrome grayscale or in color Notes: <ul style="list-style-type: none"> • Color is the factory default setting. • The printer driver is capable of overriding this setting.

Menu item	Description
Color Correction Auto Off Manual	Adjusts the color output on the printed page Notes: <ul style="list-style-type: none"> • Auto is the factory default setting. Auto applies different color conversion tables to each object on the printed page. • Off turns off color correction. • Manual allows customization of the color tables using the settings available from the Manual Color menu. • Due to the differences in additive and subtractive colors, certain colors that appear on computer monitors are impossible to duplicate on the printed page.
Print Resolution 1200 dpi 4800 CQ	Specifies the printed output resolution Notes: <ul style="list-style-type: none"> • 4800 CQ is the factory default setting. • 1200 dpi provides the highest resolution output, and increases gloss.
Toner Darkness 1–5	Lightens or darkens the printed output Notes: <ul style="list-style-type: none"> • 4 is the factory default setting. • Selecting a smaller number can help conserve toner. • If Print Mode is set to Black Only, a setting of 5 increases toner density and darkness to all print jobs. • If Print Mode is set to Color, a setting of 5 is the same as a setting of 4.
Enhance Fine Lines On Off	Enables a print mode preferable for files such as architectural drawings, maps, electrical circuit diagrams, and flow charts Notes: <ul style="list-style-type: none"> • Off is the factory default setting. • To set Enhance Fine Lines from the software program, with a document open, click File > Print, and then click Properties, Preferences, Options, or Setup. • To set Enhance Fine Lines using the Embedded Web Server, type the network printer IP address in a browser window.
Color Saver On Off	Reduces the amount of toner used for graphics and images. The amount of toner used for text is not reduced. Notes: <ul style="list-style-type: none"> • Off is the factory default setting. • On overrides Toner Darkness settings.
RGB Brightness -6–6	Adjusts brightness in color outputs Notes: <ul style="list-style-type: none"> • 0 is the factory default setting. • -6 is the maximum decrease. 6 is the maximum increase. • This does not affect files where CMYK color specifications are being used.

Menu item	Description
RGB Contrast 0–5	Adjusts contrast in color outputs Notes: <ul style="list-style-type: none"> • 0 is the factory default setting. • This does not affect files where CMYK color specifications are being used.
RGB Saturation 0–5	Adjusts saturation in color outputs Notes: <ul style="list-style-type: none"> • 0 is the factory default setting. • This does not affect files where CMYK color specifications are being used.
Color Balance Cyan –5–5 Magenta –5–5 Yellow –5–5 Black –5–5 Reset Defaults	Adjusts color in printed output by increasing or decreasing the amount of toner being used for each color Note: 0 is the factory default setting.
Color Samples sRGB Display sRGB Vivid Display—True Black Vivid Off—RGB US CMYK Euro CMYK Vivid CMYK Off—CMYK	Prints sample pages for each of the RGB and CMYK color conversion tables used in the printer Notes: <ul style="list-style-type: none"> • Selecting any setting prints the sample. • Color samples consist of a series of colored boxes along with the RGB or CMYK combination that creates the color observed. These pages can be used to help decide which combinations to use to get the desired printed output. • From a browser window, type the IP address of the printer to access a complete list of color sample pages from the Embedded Web Server.

Menu item	Description
<p>Manual Color</p> <ul style="list-style-type: none"> RGB Image <ul style="list-style-type: none"> Vivid sRGB Display Display—True Black sRGB Vivid Off RGB Text <ul style="list-style-type: none"> Vivid sRGB Display Display—True Black sRGB Vivid Off RGB Graphics <ul style="list-style-type: none"> Vivid sRGB Display Display—True Black sRGB Vivid Off 	<p>Customizes the RGB color conversions</p> <p>Notes:</p> <ul style="list-style-type: none"> • sRGB Display is the factory default setting for RGB Image. This applies a color conversion table to an output that matches the colors displayed on a computer monitor. • sRGB Vivid is the factory default setting for RGB Text and RGB Graphics. sRGB Vivid applies a color table that increases saturation. This is preferred for business graphics and text. • Vivid applies a color conversion table that produces brighter, more saturated colors. • Display—True Black applies a color conversion table that uses only black toner for neutral gray colors. • Off turns off color conversion.
<p>Manual Color</p> <ul style="list-style-type: none"> CMYK Image <ul style="list-style-type: none"> US CMYK Euro CMYK Vivid CMYK Off CMYK Text <ul style="list-style-type: none"> US CMYK Euro CMYK Vivid CMYK Off CMYK Graphics <ul style="list-style-type: none"> US CMYK Euro CMYK Vivid CMYK Off 	<p>Customizes the CMYK color conversions</p> <p>Notes:</p> <ul style="list-style-type: none"> • US CMYK is the US factory default setting. US CMYK applies a color conversion table that tries to produce output that matches SWOP color output. • Euro CMYK is the international factory default setting. Euro CMYK applies a color conversion table that tries to produce output that matches EuroScale color output. • Vivid CMYK increases color saturation for the US CMYK color conversion table. • Off turns off color conversion.
<p>Color Adjust</p>	<p>Initiates a recalibration of color conversion tables and allows the printer to make adjustments for color variations in output</p> <p>Notes:</p> <ul style="list-style-type: none"> • Calibrating starts when the menu is selected. Calibrating appears on the display until the process is finished. • Color variations in output sometimes result from changeable conditions such as room temperature and humidity. Color adjustments are made on printer algorithms. Color alignment is also recalibrated in this process.

Utilities menu

Menu item	Description
Remove Held Jobs Confidential Held Not Restored All	Removes confidential and held jobs from the printer hard disk Notes: <ul style="list-style-type: none"> • Selecting a setting affects only print jobs that are resident in the printer. Bookmarks, jobs on flash drives, and other types of held jobs are not affected. • Selecting Not Restored removes all Print and Hold jobs that were <i>not</i> restored from the disk.
Format Flash Yes No	Formats the flash memory. Flash memory refers to the memory added by installing a flash memory option card in the printer. Warning—Potential Damage: Do not turn off the printer while the flash memory is formatting. Notes: <ul style="list-style-type: none"> • A flash memory option card must be installed in the printer and operating properly for this menu item to be available. The flash memory option card must not be Read/Write or Write protected. • Selecting Yes deletes all data stored in flash memory. • No cancels the format request.
Delete Downloads on Disk Delete Now Do Not Delete	Removes downloads from the printer hard disk, including all held Jobs, buffered jobs, and parked jobs. Job accounting information is not affected. Note: Delete Now is the factory default setting.
Job Acct Stat Print Clear	Prints a list of all stored job statistics or deletes the information from the printer hard disk Notes: <ul style="list-style-type: none"> • A printer hard disk must be installed in the printer and operating properly for this menu item to be available. • Selecting Print prints a list of statistics. • Clear deletes all job statistics stored on the printer hard disk. • The Clear selection will not appear if Job Accounting is set to MarkTrack™ using NPA.
Hex Trace Activate	Assists in isolating the source of a print job problem Notes: <ul style="list-style-type: none"> • When Activate is selected, all data sent to the printer is printed in hexadecimal and character representation, and control codes are not executed. • To exit or deactivate Hex Trace, turn the printer off or reset the printer.
Coverage Estimator Off On	Provides an estimate of the percentage coverage of toner on a page. The estimate is printed on a separate page at the end of each print job. Note: Off is the factory default setting.

Menu item	Description
LCD Contrast 1–10	Adjusts the contrast lighting of the display Notes: <ul style="list-style-type: none"> • 5 is the factory default setting. • A higher setting makes the display appear lighter. • A lower setting makes the display appear darker.
LCD Brightness 1–10	Adjusts the brightness of the backlight on the display Notes: <ul style="list-style-type: none"> • 5 is the factory default setting. • A higher setting makes the display appear lighter. • A lower setting makes the display appear darker.

XPS menu

Menu item	Description
Print Error Pages Off On	Prints a page containing information on errors, including XML markup errors Note: Off is the factory default setting.

PDF menu

Menu item	Description
Scale to Fit Yes No	Scales page content to fit the selected paper size Note: No is the factory default setting.
Annotations Do Not Print Print	Prints annotations in a PDF Note: Do Not Print is the factory default setting.

PostScript menu

Menu item	Description
Print PS Error On Off	Prints a page containing the PostScript error Note: Off is the factory default setting.

Menu item	Description
Font Priority Resident Flash/Disk	Establishes the font search order Notes: <ul style="list-style-type: none"> • Resident is the factory default setting. • A formatted flash memory option card or printer hard disk must be installed in the printer and operating properly for this menu item to be available. • The flash memory option or printer hard disk cannot be Read/Write, Write, or password protected. • Job Buffer Size must not be set to 100%.
Image Smoothing On Off	Enhances the contrast and sharpness of low-resolution images and smooths their color transitions Notes: <ul style="list-style-type: none"> • Off is the factory default setting. • Image Smoothing has no effect on images that are 300 dpi or higher in resolution.

PCL Emul menu

Menu item	Description
Font Source Resident Disk Download Flash All	Specifies the set of fonts used by the Font Name menu item Notes: <ul style="list-style-type: none"> • Resident is the factory default setting. It shows the factory default set of fonts downloaded into RAM. • Flash and Disk settings show all fonts resident in that option. • Flash option must be properly formatted and cannot be Read/Write, Write, or password protected. • Download shows all the fonts downloaded into RAM. • All shows all fonts available to any option.
Font Name RO Courier	Identifies a specific font and the option where it is stored Notes: <ul style="list-style-type: none"> • RO Courier is the factory default setting. • RO Courier shows the font name, font ID, and storage location in the printer. The font source abbreviation is R for Resident, F for Flash, K for Disk, and D for download.

Menu item	Description
Symbol Set 10U PC-8 12U PC-850	Specifies the symbol set for each font name Notes: <ul style="list-style-type: none"> • 10U PC-8 is the US factory default setting. • 12U PC-850 is the international factory default setting. • A symbol set is a set of alphabetic and numeric characters, punctuation, and special symbols. Symbol sets support the different languages or specific programs such as math symbols for scientific text. Only the supported symbol sets are shown.
PCL Emulation Settings Point Size 1.00–1008.00	Changes the point size for scalable typographic fonts Notes: <ul style="list-style-type: none"> • 12 is the factory default setting. • Point Size refers to the height of the characters in the font. One point equals approximately 1/72 of an inch. • Point sizes can be increased or decreased in 0.25-point increments.
PCL Emulation Settings Pitch 0.08–100	Specifies the font pitch for scalable monospaced fonts Notes: <ul style="list-style-type: none"> • 10 is the factory default setting. • Pitch refers to the number of fixed-space characters per inch (cpi). • Pitch can be increased or decreased in 0.01-cpi increments. • For nonscalable monospaced fonts, the pitch appears on the display but cannot be changed.
PCL Emulation Settings Orientation Portrait Landscape	Specifies the orientation of text and graphics on the page Notes: <ul style="list-style-type: none"> • Portrait is the factory default setting. • Portrait prints text and graphics parallel to the short edge of the page. • Landscape prints text and graphics parallel to the long edge of the page.
PCL Emulation Settings Lines per Page 1–255 60 64	Specifies the number of lines that print on each page Notes: <ul style="list-style-type: none"> • 60 is the US factory default setting. 64 is the international default setting. • The printer sets the amount of space between each line based on the Lines per Page, Paper Size, and Orientation settings. Select the desired Paper Size and Orientation before setting Lines per Page.
PCL Emulation Settings A4 Width 198 mm 203 mm	Sets the printer to print on A4-size paper Notes: <ul style="list-style-type: none"> • 198 mm is the factory default setting. • The 203-mm setting sets the width of the page to allow the printing of eighty 10-pitch characters.

Menu item	Description
PCL Emulation Settings Auto CR after LF On Off	Specifies whether the printer automatically performs a carriage return (CR) after a line feed (LF) control command Notes: <ul style="list-style-type: none"> • Off is the factory default setting. • Setting alterations are duplicated in the PPDS menu.
PCL Emulation Settings Auto LF after CR On Off	Specifies whether the printer automatically performs a line feed (LF) after a carriage return (CR) control command Notes: <ul style="list-style-type: none"> • Off is the factory default setting. • Setting alterations are duplicated in the PPDS menu.
Tray Renumber Assign MP Feeder Off None 0–199 Assign Tray <x> Off None 0–199 Assign Manual Paper Off None 0–199 Assign Man Env Off None 0–199	Configures the printer to work with printer software or programs that use different source assignments for trays, drawers, and feeders Notes: <ul style="list-style-type: none"> • Off is the factory default setting. • None is not an available selection. It is displayed only when it is selected by the PCL 5 interpreter. • None ignores the Select Paper Feed command. • 0–199 allows a custom setting to be assigned.
Tray Renumber View Factory Def MPF Default = 8 T1 Default = 1 T2 Default = 4 T3 Default = 5 T4 Default = 20 T5 Default = 21 Env Default = 6 MPaper Default = 2 MEnv Default = 3	Displays the factory default setting assigned to each tray, drawer, or feeder
Tray Renumber Restore Defaults Yes No	Returns all tray, drawer, and feeder assignments to the factory default settings

HTML menu

Menu item		Description
Font Name Albertus MT Antique Olive Apple Chancery Arial MT Avant Garde Bodoni Bookman Chicago Clarendon Cooper Black Copperplate Coronet Courier Eurostile Garamond Geneva Gill Sans Goudy Helvetica Hoefler Text	Intl CG Times Intl Courier Intl Univers Joanna MT Letter Gothic Lubalin Graph Marigold MonaLisa Recut Monaco New CenturySbk New York Optima Oxford Palatino StempelGaramond Taffy Times TimesNewRoman Univers Zapf Chancery	Sets the default font for HTML documents Note: The Times font is used in HTML documents that do not specify a font.

Menu item	Description
Font Size 1–255 pt	Sets the default font size for HTML documents Notes: <ul style="list-style-type: none"> • 12 pt is the factory default setting. • Font size can be increased in 1-point increments.
Scale 1–400%	Scales the default font for HTML documents Notes: <ul style="list-style-type: none"> • 100% is the factory default setting. • Scaling can be increased in 1% increments.
Orientation Portrait Landscape	Sets the page orientation for HTML documents Note: Portrait is the factory default setting.
Margin Size 8–255 mm	Sets the page margin for HTML documents Notes: <ul style="list-style-type: none"> • 19 mm is the factory default setting. • Margin size can be increased in 1-mm increments.

Menu item	Description
Backgrounds Do Not Print Print	Specifies whether to print backgrounds on HTML documents Note: Print is the factory default setting.

Image menu

Menu item	Description
Auto Fit On Off	Selects the optimal paper size, scaling, and orientation Notes: <ul style="list-style-type: none"> • On is the factory default setting. • The On setting overrides scaling and orientation settings for some images.
Invert On Off	Inverts bi-tonal monochrome images Notes: <ul style="list-style-type: none"> • Off is the factory default setting. • This setting does not apply to GIF or JPEG images.
Scaling Anchor Top Left Best Fit Anchor Center Fit Height/Width Fit Height Fit Width	Scales the image to fit the selected paper size Notes: <ul style="list-style-type: none"> • Best Fit is the factory default setting. • When Auto Fit is set to On, Scaling is automatically set to Best Fit.
Orientation Portrait Landscape Rev Portrait Rev Landscape	Sets the image orientation Note: Portrait is the factory default setting.

PictBridge menu

Menu item	Description
Photo Size Auto L 2L Hagaki Postcard Card Size 100x150 mm 4x6 inches 8x10 inches Letter A4 A5 JIS B5	Selects the optimal photo size Notes: <ul style="list-style-type: none"> • Auto is the factory default setting. • If both the printer and the PictBridge-enabled digital camera have a value for this setting, the camera value <i>always</i> supersedes the printer value.
Layout Auto Off 2 Up 3 Up 4 Up 6 Up 9 Up 12 Up 16 Up Index Print	Selects the optimal photo layout Notes: <ul style="list-style-type: none"> • Auto is the factory default setting. • If both the printer and the PictBridge-enabled digital camera have a value for this setting, the camera value <i>always</i> supersedes the printer value.
Quality Normal Draft Fine	Selects the optimal quality Notes: <ul style="list-style-type: none"> • Normal is the factory default setting. • If both the printer and the PictBridge-enabled digital camera have a value for this setting, the camera value <i>always</i> supersedes the printer value.
Paper Source MP Feeder Tray <x> Manual Paper	Sets the tray the paper pulls from Notes: <ul style="list-style-type: none"> • MP Feeder is the factory default setting. • If both the printer and the PictBridge-enabled digital camera have a value for this setting, the camera value <i>always</i> supersedes the printer value.

Flash Drive menu

Menu item	Description
Copies 1–999	Specifies a default number of copies for each print job Note: 1 is the factory default setting.

Menu item	Description
Paper Source Tray <x> Manual Feeder Envelope Feeder	Sets a default paper source for all print jobs Note: Tray 1 (standard tray) is the factory default setting.
Color On Off	Allows the printer to generate colored output Note: On is the factory default setting.
Collate Off (1,1,1,2,2,2) On (1,2,1,2,1,2)	Stacks the pages of a print job in sequence when printing multiple copies Notes: <ul style="list-style-type: none"> • Off is the factory default setting. No pages will be collated. • The On setting stacks the print job sequentially.
Sides (Duplex) 1 sided 2 sided	Controls whether the job prints on one side or both sides of the paper Note: 1 sided is the factory default setting.
Duplex Binding Long Edge Short Edge	Defines the way duplexed pages are bound and how the printing on the back of the page is oriented in relation to the printing on the front of the page Notes: <ul style="list-style-type: none"> • Long Edge is the factory default setting. • Long Edge specifies that binding be placed on the left edge of portrait pages and the top edge of landscape pages. • Short Edge specifies that binding be placed on the top edge of portrait pages and the left edge of landscape pages.
Orientation Auto Landscape Portrait	Specifies the orientation of a multiple-page sheet Note: Auto is the factory default setting. The printer chooses between portrait and landscape.
N-up (pages-side) Off 2-Up 3-Up 4-Up 6-Up 9-Up 12-Up 16-Up	Specifies that multiple-page images be printed on one side of a sheet of paper Notes: <ul style="list-style-type: none"> • Off is the factory default setting. • The number selected is the number of page images that will print per side.
N-up Border None Solid	Prints a border around each page image when using N-up (pages-side) Note: None is the factory default setting.

Menu item	Description
N-up Ordering Horizontal Reverse Horizontal Reverse Vertical Vertical	Specifies the positioning of multiple-page images when using N-up (pages-side) Notes: <ul style="list-style-type: none"> • Horizontal is the factory default setting. • Positioning depends on the number of images and whether the images are in portrait or landscape orientation.
Separator Sheets None Between Copies Between Jobs Between Pages	Specifies whether blank separator sheets are inserted Notes: <ul style="list-style-type: none"> • None is the factory default setting. • Between Copies inserts a blank sheet between each copy of a print job if Collation is set to On. If Collation is set to Off, then a blank page is inserted between each set of printed pages, such as after all page 1's and after all page 2's. • Between Jobs inserts a blank sheet between print jobs. • Between Pages inserts a blank sheet between each page of the print job. This setting is useful when printing transparencies or inserting blank pages in a document for notes.
Separator Source Tray <x> Manual Feeder	Specifies the paper source for separator sheets Notes: <ul style="list-style-type: none"> • Tray 1 (standard tray) is the factory default setting. • From the Paper menu, Configure MP must be set to Cassette in order for Manual Feeder to appear as a menu setting.
Blank Pages Do Not Print Print	Specifies whether blank pages are inserted in a print job Note: Do Not Print is the factory default setting.

Help menu

The Help menu consists of a series of Help pages that are stored in the printer as PDFs. They contain information about using the printer and performing printing tasks.

English, French, German, and Spanish translations are stored in the printer. Other translations are available on the *Software and Documentation CD*.

Menu item	Description
Print All	Prints all the guides
Color Quality	Provides information about adjusting and customizing color printing
Print Quality	Provides information about solving print quality issues
Printing Guide	Provides information about loading paper and other speciality media
Media Guide	Provides a list of the paper sizes supported in trays, drawers, and feeders
Print Defects	Provides help in determining the printer part causing a repetitive defect
Menu Map	Provides a list of the printer control panel menus and settings

Menu item	Description
Information Guide	Provides help in locating additional information
Connection Guide	Provides information about connecting the printer locally (USB) or to a network
Moving Guide	Provides instructions for safely moving the printer
Supplies Guide	Provides part numbers for ordering supplies

Maintaining the printer

Periodically, certain tasks are required to maintain optimum print quality.

Cleaning the exterior of the printer

- 1 Make sure that the printer is turned off and unplugged from the wall outlet.

 **CAUTION—SHOCK HAZARD:** To avoid the risk of electric shock when cleaning the exterior of the printer, unplug the power cord from the wall outlet and disconnect all cables to the printer before proceeding.

- 2 Remove paper from the standard exit bin.
- 3 Dampen a clean, lint-free cloth with water.

Warning—Potential Damage: Do not use household cleaners or detergents, as they may damage the finish of the printer.

- 4 Wipe only the outside of the printer, making sure to include the standard exit bin.

Warning—Potential Damage: Using a damp cloth to clean the interior may cause damage to your printer.

- 5 Make sure the paper support and standard exit bin are dry before beginning a new print job.

Cleaning the printhead lenses

Clean the printhead lenses when you encounter print quality problems.

- 1 Open the front door.

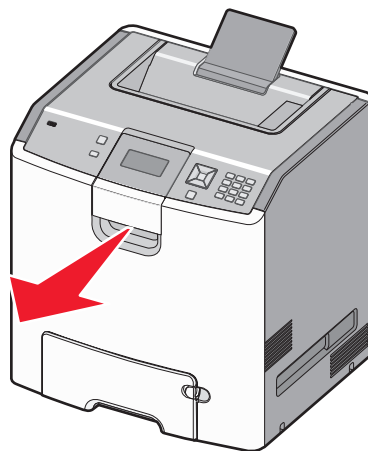

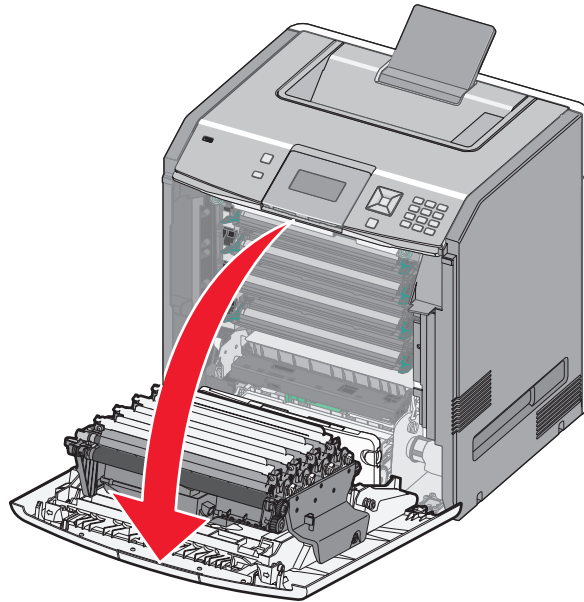

Warning—Potential Damage: To avoid overexposing the photoconductor units, do not leave the front door open for more than 10 minutes.

- 2 Remove all four toner cartridges. Do not remove the photoconductor units for this procedure.
- 3 Locate the four printhead lenses.

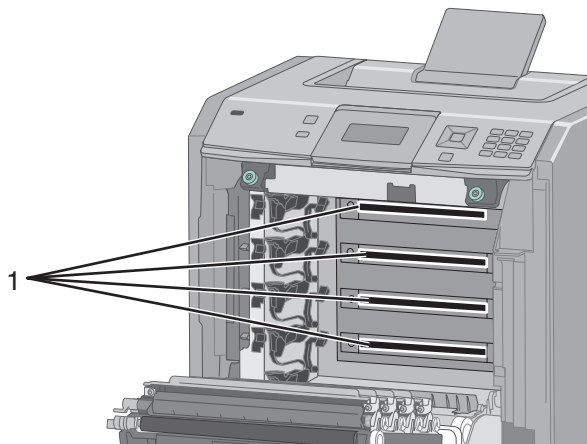

- 4 Clean the lenses using a can of compressed air.

Warning—Potential Damage: Do not touch the printhead lenses.

- 5 Reinstall the four toner cartridges.

6 Close the front door.

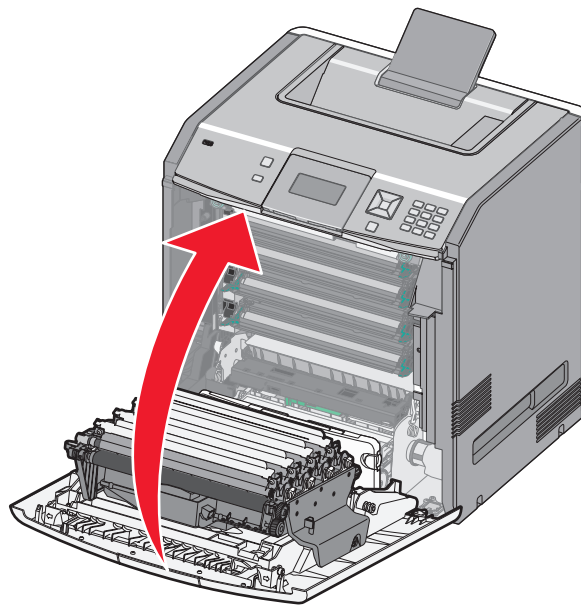

Storing supplies

Choose a cool, clean storage area for the printer supplies. Store supplies right side up in their original packing until you are ready to use them.

Do not expose supplies to:

- Direct sunlight
- Temperatures above 35°C (95°F)
- High humidity above 80%
- Salty air
- Corrosive gases
- Heavy dust

Checking the status of supplies

A message appears on the display when a replacement supply item is needed or when maintenance is required.

Checking the status of supplies from the printer control panel

- 1 Make sure the printer is on and **Ready** appears.
- 2 From the printer control panel, press the up or down arrow button until **√ Status/Supplies** appears, and then press .
- 3 Press the up or down arrow button until **√ view supplies** appears, and then press .
The status of each supply appears.

Checking the status of supplies from a network computer

Note: The computer must be connected to the same network as the printer.

- 1 Type the printer IP address into the address field of your Web browser.

Note: If you do not know the IP address of the printer, print a network setup page and locate the IP address in the TCP/IP section.

- 2 Click **Device Status**. The Device Status page appears, displaying a summary of supply levels.

Ordering supplies

To order supplies in the U.S., contact Lexmark at 1-800-539-6275 for information about Lexmark authorized supplies dealers in your area. In other countries or regions, visit the Lexmark Web Site at www.lexmark.com or contact the place where you purchased the printer.

Note: All life estimates for printer supplies assume printing on letter- or A4-size plain paper.

Ordering toner cartridges

When **88 Cyan cartridge low**, **88 Magenta cartridge low**, **88 Yellow cartridge low**, or **88 Black cartridge low** appears, order a new cartridge.

When **88 Replace Cyan cartridge**, **88 Replace Magenta cartridge**, **88 Replace Yellow cartridge**, or **88 Replace Black cartridge** appears, you *must* replace the specified cartridge.

Estimated cartridge yield is based on the ISO / IEC 19798 standard (with about 5% coverage per color). Extremely low print coverage (less than 1.25% for a color) for extended periods of time may negatively affect actual yield for that color and may cause cartridge parts to fail prior to exhaustion of toner.

Ordering photoconductors

When **84 photoconductor low**, or **84 <color> photoconductor nearly low** appears, order a replacement photoconductor.

When **84 Replace <color> photoconductor** appears, you *must* replace the specified photoconductor.

Part name	Part number
Photoconductor	C734X20G
Photoconductor, Multi-Pack	C734X24G

Ordering a fuser or a transfer module

When **80 Fuser Life Warning** or **83 Transfer Module Life Warning** appears, order a replacement fuser or a transfer module.

When **80 Replace Fuser** or **83 Replace Transfer Module** appears, install the new fuser or the new transfer module. For installation information, see the documentation that came with the part.

Part name	Part number
Fuser	40X5095 (100 volt) 40X5093 (115 volt) 40X5094 (230 volt)
Transfer Module	40X5096

Ordering a waste toner box

When **82 Waste toner box nearly full** appears, order a replacement waste toner box. When **82 Replace waste toner box** appears, you *must* replace the waste toner box.

Note: Waste toner box reuse is not recommended.

Part name	Part number
Waste Toner Box	C734X77G

Replacing supplies

Replacing a toner cartridge

When **88 Replace <color> cartridge**, **88 <color> cartridge nearly low**, or **88 <color> cartridge low** appears on the printer control panel, or when print becomes faded, try to extend the life of the specified cartridge.

- 1 Open the front door.

Warning—Potential Damage: Make sure the printer is not open for 10 minutes or more to avoid overexposing the photoconductor units to light.

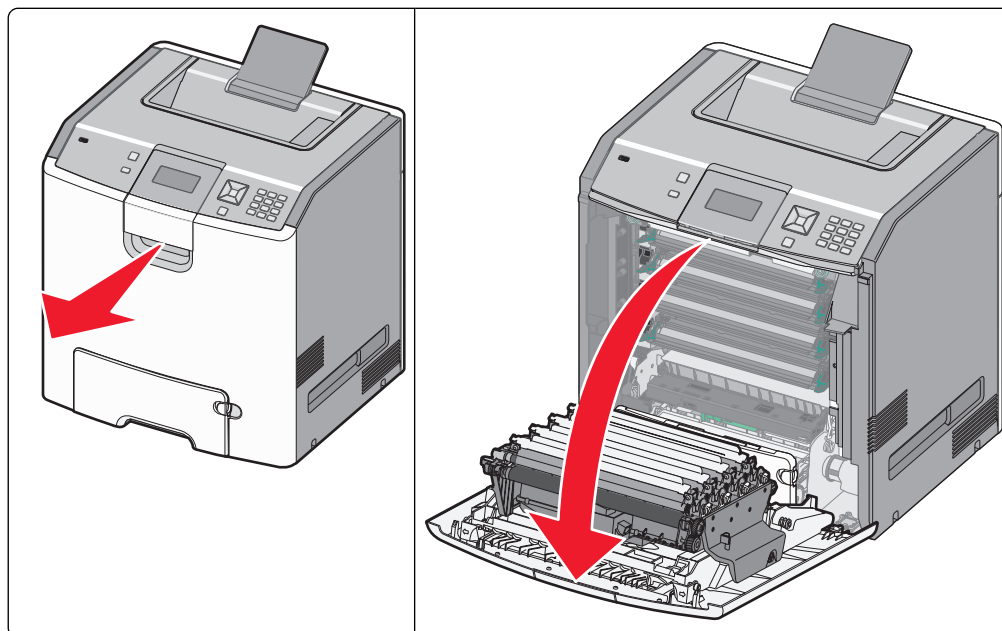

- 2** Pull up and out on the green tabs of the specified cartridge to remove it from the printer.

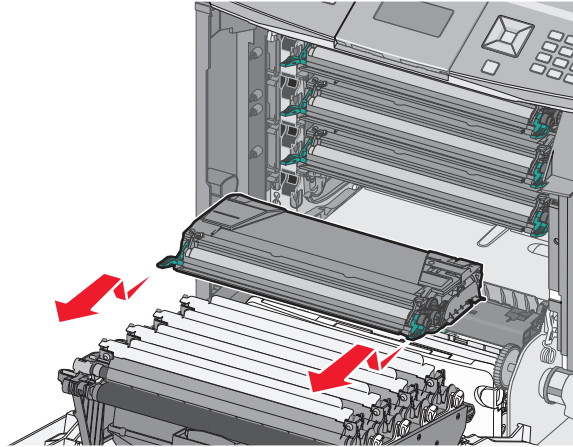

- 3** Shake the cartridge front to back and side to side to redistribute the toner.

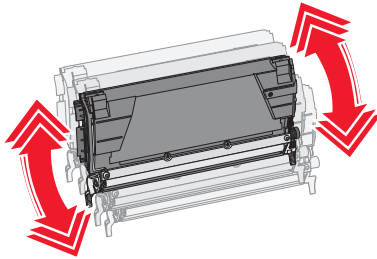

- 4** Reinsert the cartridge to continue printing.

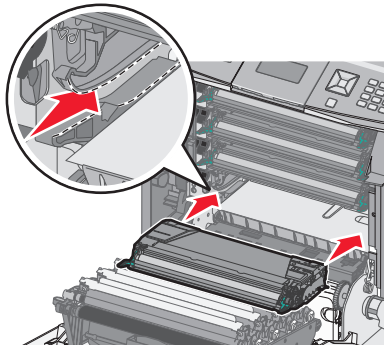

- 5** Repeat this process multiple times until printed text and graphics remain faded.

When printed text and graphics remain faded, replace the specified cartridge. Repeat steps 1 and 2, and then follow the steps below.

6 Unpack a new cartridge.

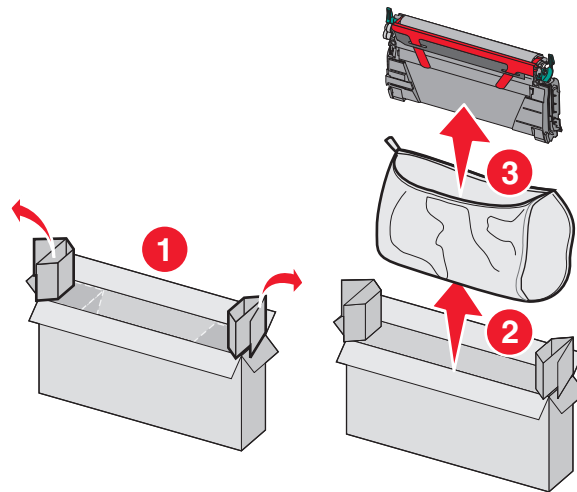

7 Place the old cartridge in the replacement cartridge shipping box, and then attach the return label to the box for shipping.

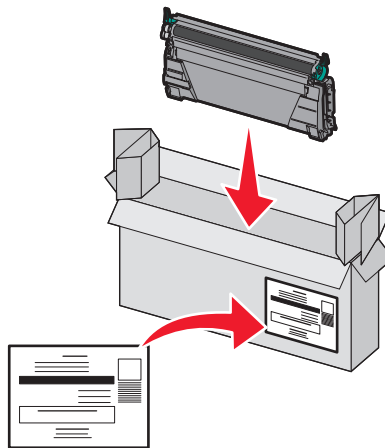

8 Shake the new cartridge front to back and side to side to evenly distribute the toner.

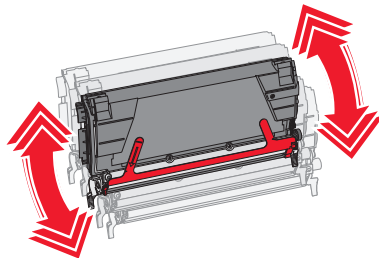

- 9 Remove the red packing strip from the new cartridge.

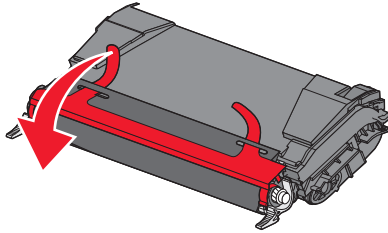

- 10 Insert the new cartridge into the printer.

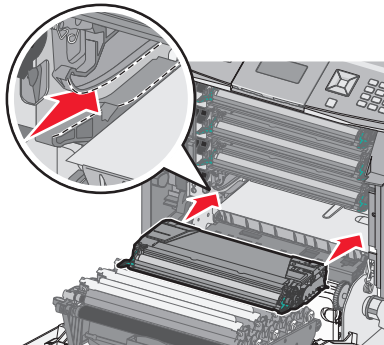

- 11 Close the front door.

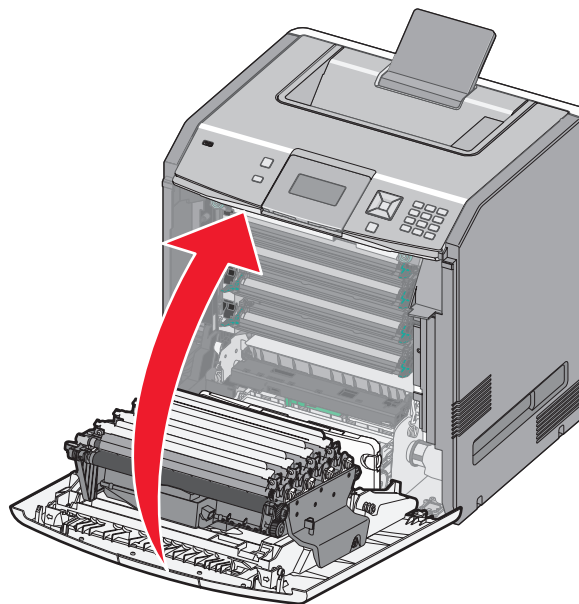

Note: Make sure each cartridge is fully pushed in. If a cartridge is not installed correctly, the printer may issue a **<color> Cartridge Missing** message, where **<color>** is **Black, Cyan, Magenta, or Yellow**. The printer may also issue the message **Close front door**.

If either of these messages appears, follow these steps to clear the printer control panel message and continue printing:

- 1 Open the front door.
- 2 Remove the specified cartridge.
- 3 Reinstall the specified cartridge.

- 4 Close the front door.
- 5 Check the printer control panel to see if it is clear of messages.
- 6 Repeat as needed for additional toner cartridge replacement.

Replacing a photoconductor

There are three different display messages that may appear when a photoconductor replacement is necessary: **84 Replace <color> photoconductor**, **84 <color> photoconductor nearly low**, or **84 <color> photoconductor low**.

Note: A replacement photoconductor can be used with any color.

Replacing a photoconductor is a two-part process. First, complete the illustrated steps to replace the photoconductor, and then reset the life count and clear printer messages.

- 1 Open the front door.

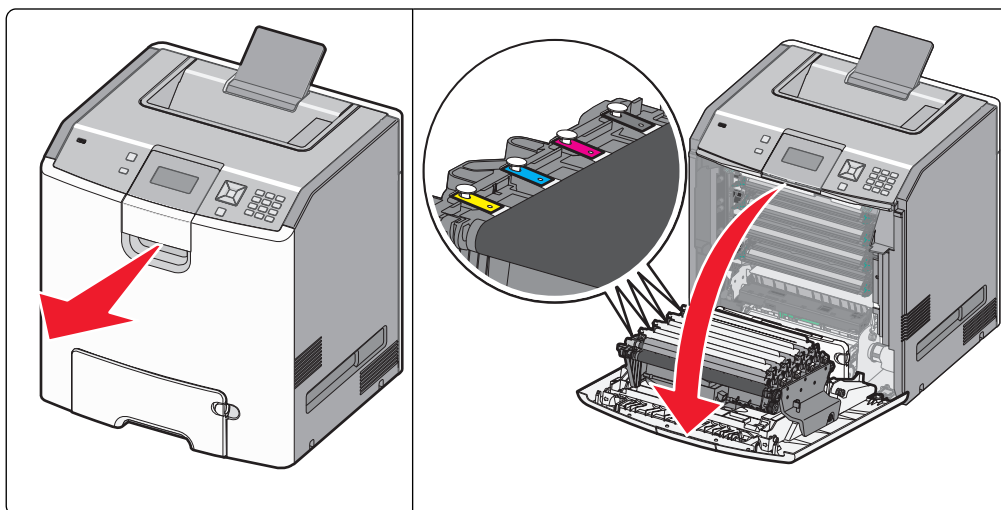

Warning—Potential Damage: To avoid overexposing the photoconductors, do not leave the door open for more than 10 minutes.

- 2 Pull the specified photoconductor up, and then slide it to the right to remove it from the printer.

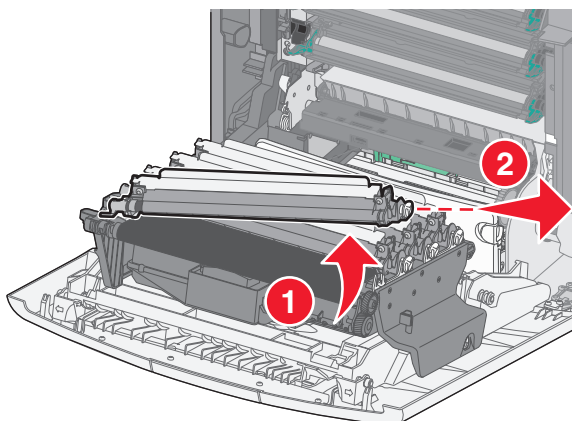

- 3 Unpack the replacement photoconductor.

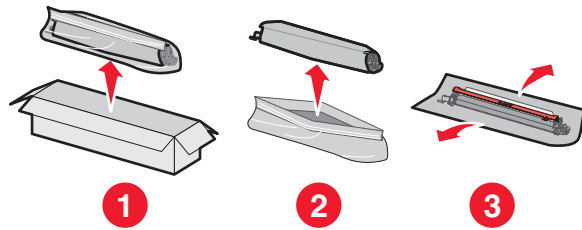

Warning—Potential Damage: Do not touch the shiny area on the photoconductor drum. Touching it could damage the photoconductor.

- 4 Align and insert the left end of the photoconductor, and then press the right end until it *clicks* into place.

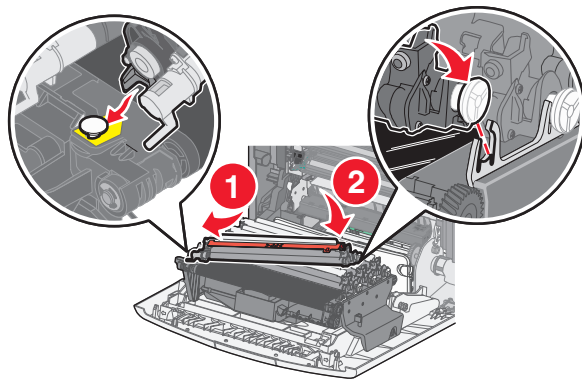

- 5 Remove the red packing strip from the top of the photoconductor.

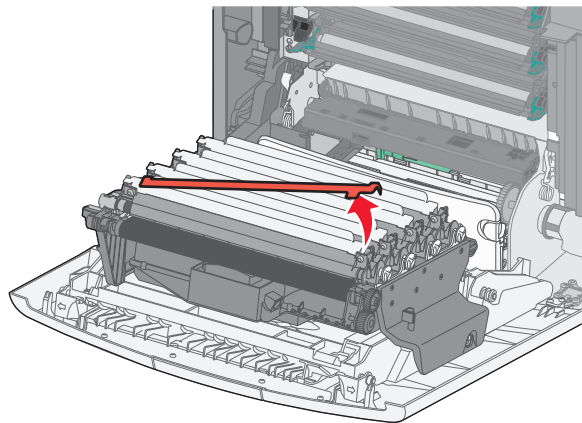

- 6 Place the old photoconductor into the replacement photoconductor box, and then place the return label on the box for shipping to Lexmark for recycling.

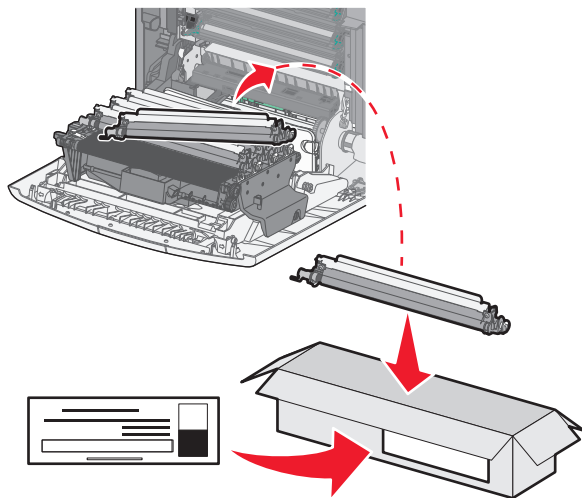

- 7 Close the front door.

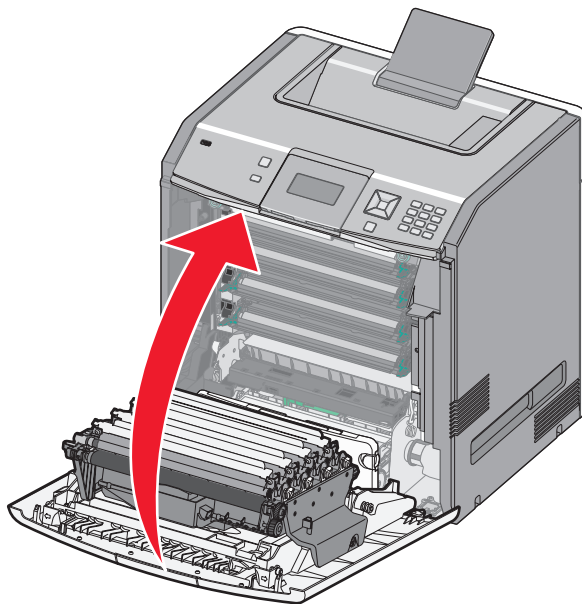

- 8 If you see **84 Replace <color> photoconductor**, **84 <color> photoconductor nearly low**, or **84 <color> photoconductor low** on the display, then press the up or down arrow button until **√ Supply Replaced** appears, and then press .

Note: Failure to reset the life count may result in degraded print quality.







Replaced <color> photoconductor appears.

√ Yes appears.

- 9 Press to clear the message.

If you are prompted to replace only one photoconductor, then the **Ready** screen appears, and the task is complete. If you are prompted to replace additional photoconductors, repeat steps 1 to 9 for each additional photoconductor. After all photoconductors have been replaced, **Ready** appears, and the task is complete.

If you see **Ready** on the printer display after you have replaced a photoconductor, continue with steps 1–7:

- 1 To specify the replaced photoconductor, press .
✓**Supplies Menu** appears.
- 2 Press .
✓**Replace Supply** appears.
- 3 Press .
- 4 Press the up or down arrow button until ✓**All**, ✓**Cyan photoconductor**, ✓**Magenta photoconductor**, ✓**Yellow photoconductor**, or ✓**Black photoconductor** appears, depending on the photoconductor you just replaced.
- 5 Press .
<color> **photoconductor replaced** appears.
✓**Yes** appears.
- 6 Press .
- 7 Press  until **Ready** appears.

Replacing the waste toner box

Replace the waste toner box when **82 Replace waste toner box** or **82 Waste toner box nearly full** appears. The printer will not continue printing until the waste toner box is replaced.

- 1 Unpack the replacement waste toner box, and remove it from its shipping box.

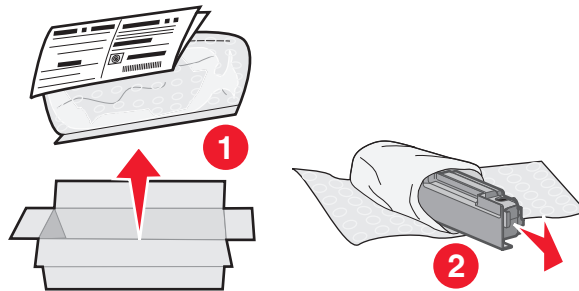

- 2 Locate the waste toner box release button on the left side of the printer.
- 3 Press the release button to the left, and pull the waste toner box out to remove it from the printer.

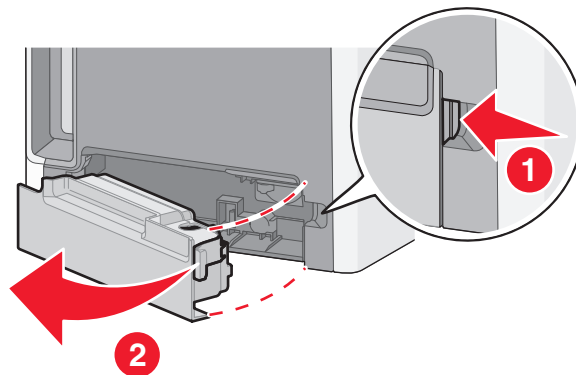

- 4** Peel the seal from the side of the full waste toner box as shown, and then place it over the hole to seal off the waste toner box.

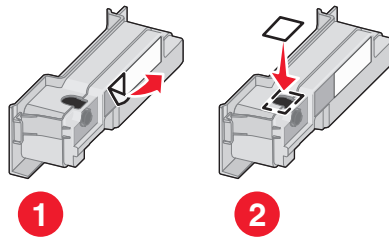

- 5** Place the sealed waste toner box in the recycling bag.
6 Place the bag into the shipping box you just removed the replacement part from.

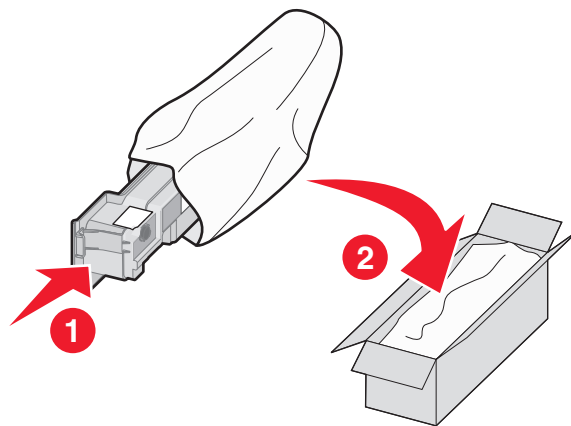

- 7** Peel the recycling label off, and place it on the shipping box.

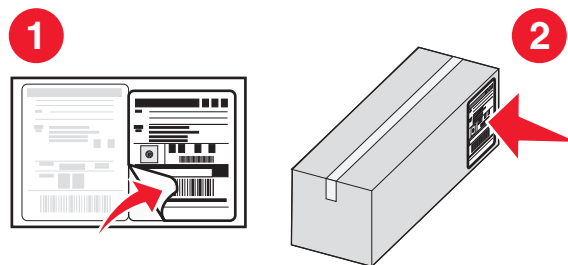

- 8** Insert the new waste toner box into the printer.

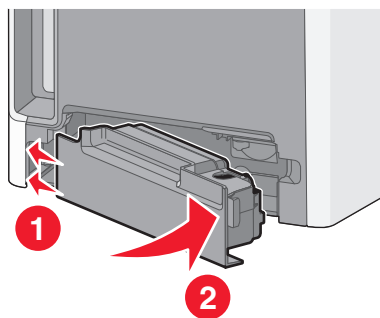

Moving the printer

Before moving the printer

CAUTION—POTENTIAL INJURY: The printer weight is greater than 18 kg (40 lb) and requires two or more trained personnel to lift it safely.

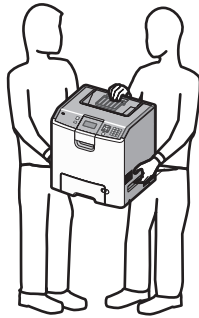

CAUTION—POTENTIAL INJURY: Before moving the printer, follow these guidelines to avoid personal injury or printer damage:

- Turn the printer off using the power switch, and then unplug the power cord from the wall outlet.
- Disconnect all cords and cables from the printer before moving it.
- Lift the printer off the optional drawer, and set it aside instead of trying to lift the drawer and printer at the same time.

Note: Use the handholds located on both sides and rear of the printer to lift it off the optional drawer.

Warning—Potential Damage: Damage to the printer caused by improper moving is not covered by the printer warranty.

Moving the printer to another location

The printer and options can be safely moved to another location by following these precautions:

- Any cart used to move the printer must have a surface able to support the full footprint of the printer. Any cart used to move the options must have a surface able to support the dimensions of the options.
- Keep the printer in an upright position.
- Avoid severe jarring movements.

Setting the printer up in a new location

When the printer is set up, allow clearance around it as shown.

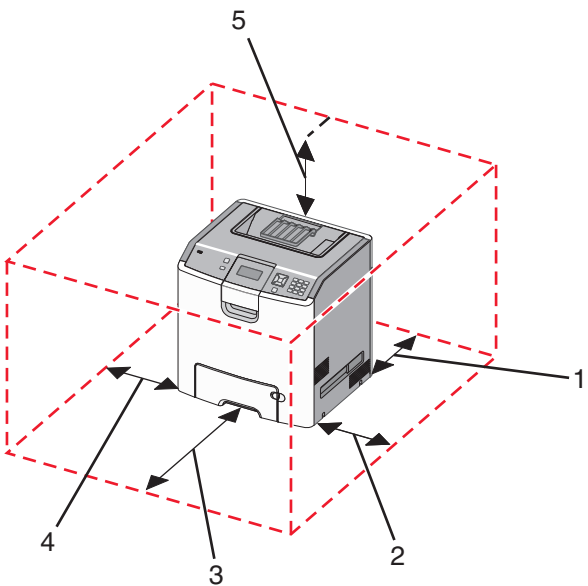
	1	152.4 mm (6.0 in.)
	2	101.6 mm (4.0 in.)
	3	609.6 mm (24.0 in.)
	4	152.4 mm (6.0 in.)
	5	304.8 mm (12.0 in.)

Shipping the printer

When shipping the printer, use the original packaging or call the place of purchase for a relocation kit.

Administrative support

Finding advanced networking and administrator information

For more advanced system support tasks, see the *Networking Guide* on the *Software and Documentation* CD and the *Embedded Web Server Administrator's Guide* on the Lexmark Web site at <http://support.lexmark.com>.

Using the Embedded Web Server

- 1 Type the printer IP address into the address field of your Web browser.

Note: If you do not know the IP address of the printer, then you can:

- View the IP address on the printer control panel in the TCP/IP section under the Networks/Ports menu.
- Print a network setup page or the menu settings pages and locate the IP address in the TCP/IP section.

- 2 Click one of the tabs to access information about the printer, change settings, or view a report.

Note: If the printer is connected to a computer by a USB or parallel cable, then open the Local Printer Settings Utility for Windows or Printer Settings for Macintosh to access printer menus.

Checking the virtual display

The virtual display works as an actual display would work on a printer control panel, showing printer messages.

To access the Embedded Web Server, type the printer IP address into the address field of your Web browser.

Note: If you do not know the IP address of the printer, then you can:

- View the IP address on the printer control panel in the TCP/IP section under the Networks/Ports menu.
- Print a network setup page or the menu settings pages and locate the IP address in the TCP/IP section.

The virtual display appears in the top left corner of the screen.

Checking the device status

From the Device Status page of the Embedded Web Server, it is possible to see paper tray settings, the level of toner in the toner cartridge, the percentage of life remaining in the photoconductor kit, and capacity measurements of certain printer parts.

- 1 Type the printer IP address in the address field of your Web browser.

Note: If you do not know the IP address of the printer, then you can:

- View the IP address on the printer control panel in the TCP/IP section under the Networks/Ports menu.
- Print a network setup page or the menu settings pages and locate the IP address in the TCP/IP section.

- 2 Click **Device Status**.

Setting up e-mail alerts

You can have the printer send you an e-mail when the supplies are getting low or when the paper needs to be changed, added, or unjammed.

- 1 Type the printer IP address into the address field of your Web browser.

Note: If you do not know the IP address of the printer, then you can:

- View the IP address on the printer control panel in the TCP/IP section under the Networks/Ports menu.
- Print a network setup page or the menu settings pages and locate the IP address in the TCP/IP section.

- 2 Click **Settings**.

- 3 Under Other Settings, click **E-mail Alert Setup**.

- 4 Select the items for notification and type the e-mail addresses that you want to receive e-mail alerts.

- 5 Click **Submit**.

Note: See your system support person to set up the e-mail server.

Viewing reports

You can view some reports from the Embedded Web Server. These reports are useful for assessing the status of the printer, the network, and supplies.

- 1 Type the printer IP address into the address field of your Web browser.

Note: If you do not know the IP address of the printer, then you can:





- View the IP address on the printer control panel in the TCP/IP section under the Networks/Ports menu.
- Print a network setup page or the menu settings pages and locate the IP address in the TCP/IP section.

- 2 Click **Reports**, and then click the type of report you want to view.

Restoring the factory default settings

If you want to retain a list of the current menu settings for reference, then print a menu settings page before you restore the factory default settings. For more information, see “Printing a menu settings page” on page 33.

Warning—Potential Damage: Restoring factory defaults returns most printer settings to the original factory default setting. Exceptions include the display language, custom sizes and messages, and Network/Port menu settings. All downloads stored in RAM are deleted. Downloads stored in flash memory or on a printer hard disk are not affected.

- 1 From the printer control panel, press .
 - 2 Press the up or down arrow button until **✓Settings** appears, and then press .
 - 3 Press the up or down arrow button until **✓General Settings** appears, and then press .
 - 4 Press the up or down arrow button until **✓Factory Defaults** appears, and then press .
 - 5 Press the up or down arrow button until **✓Restore Now** appears, and then press .
- Restoring Factory Defaults** appears.

Copying printer settings to other printers

Using the Embedded Web Server, you can copy printer settings to up to 15 other network printers.

1 Type the printer IP address into the address field of your Web browser.

Note: If you do not know the IP address of the printer, then you can:

- View the IP address on the printer control panel in the TCP/IP section under the Networks/Ports menu.
- Print a network setup page or the menu settings pages and locate the IP address in the TCP/IP section.

2 Click **Copy Printer Settings**.

3 To change the language, select a language from the drop-down list, and then click **Click here to submit language**.

4 Click **Printer Settings**.

5 Enter the IP addresses of the source and target printers.

Note: To add additional target printers, click the **Add Target IP** button.

6 Click **Copy Printer Settings**.

Clearing jams

Jam error messages appear on the display and include the area of the printer where the jam occurred. When there is more than one jam, the number of jammed pages is displayed.

Avoiding jams

The following hints can help you avoid jams:

Paper tray recommendations

- Make sure the paper lies flat in the tray.
- Do not remove a tray while the printer is printing.
- Do not load a tray while the printer is printing. Load it prior to printing, or wait for a prompt to load it.
- Do not load too much paper. Make sure the stack height does not exceed the indicated maximum height.
- Make sure the guides in the tray or the multipurpose feeder are properly positioned and are not pressing too tightly against the paper or envelopes.
- Push the tray in firmly after loading paper.

Paper recommendations

- Use only recommended paper or specialty media.
- Do not load wrinkled, creased, damp, bent, or curled paper.
- Flex, fan, and straighten paper before loading it.

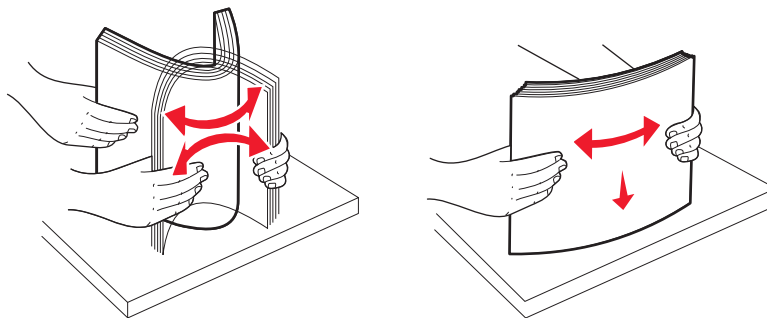

- Do not use paper that has been cut or trimmed by hand.
- Do not mix paper sizes, weights, or types in the same stack.
- Make sure all sizes and types are set correctly in the printer control panel menus.
- Store paper per the manufacturer's recommendations.

Accessing jam areas

When a jam occurs, a message indicating the jam location appears on the display. Open doors and covers and remove trays to access jam locations. To resolve any paper jam message, you must clear all jammed paper from the paper path and then press .

Jam number	Jam location	What to do
200–201	In the printer	Open the front door, remove the photoconductor unit, and then remove any jams.
202	In the printer	Open the front door and top cover, and then remove any jams.
203	In the printer or standard exit bin	Open the front door and top cover, and then remove any jams.
230	In the printer	Remove Tray 1, open the front door, and then remove any jams.
24x	In the paper trays	Open each tray, and then remove any jams.
250	In the multipurpose feeder	<ol style="list-style-type: none"> 1 Remove all media from the multipurpose feeder. 2 Flex and stack the media. 3 Reload the multipurpose feeder. 4 Adjust the paper guide.

200–201 paper jams

 **CAUTION—HOT SURFACE:** The inside of the printer might be hot. To reduce the risk of injury from a hot component, allow the surface to cool before touching.

1 Open the front door.

Warning—Potential Damage: To avoid overexposing the photoconductors, do not leave the front door open longer than 10 minutes.

2 If the jam is behind the toner cartridge area, pull the jammed paper up and out.

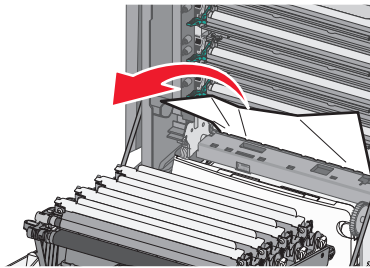

Note: Make sure all paper fragments are removed.

- 3** If the jam is under the photoconductor units:
- Pull the jam towards you.

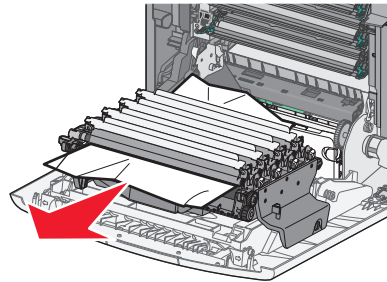

Note: You may need to remove the photoconductor units if the paper is lodged too tightly under them.

- Remove each photoconductor unit, and place it on a flat surface.

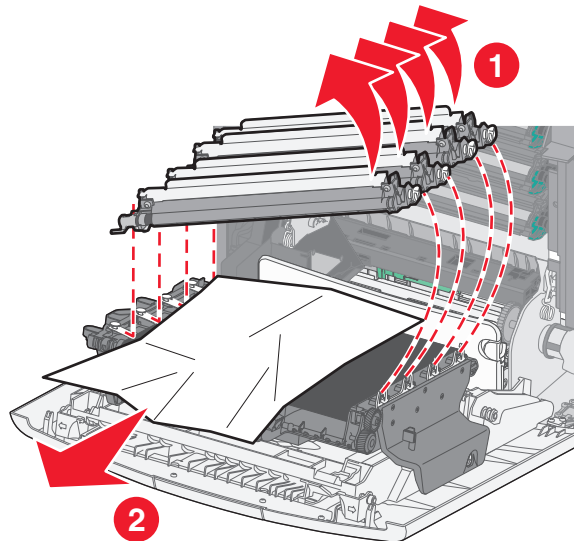

- Remove the jammed paper, and then replace each photoconductor unit.

4 Close the front door.

5 Press .

202 paper jam

If the paper is visible in the standard exit bin, then grasp the paper and pull it away from the bin.

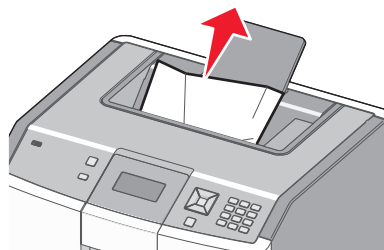

Paper jam under the fuser unit

Warning—Potential Damage: To avoid overexposing the photoconductors, do not leave the front door open longer than 10 minutes.

- 1 Open the front door, and then open the top cover.

 **CAUTION—HOT SURFACE:** The inside of the printer might be hot. To reduce the risk of injury from a hot component, allow the surface to cool before touching.

- 2 Grasp the jammed paper on each side and pull it towards you.

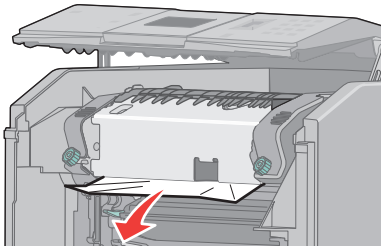

- 3 Close the top cover, and then close the front door.

- 4 Press .

Paper jam behind the fuser unit

Warning—Potential Damage: To avoid overexposing the photoconductors, do not leave the front door open longer than 10 minutes.

- 1 Open the front door, and then open the top cover.

 **CAUTION—HOT SURFACE:** The inside of the printer might be hot. To reduce the risk of injury from a hot component, allow the surface to cool before touching.

- 2 If the paper is jammed behind the fuser, then you will need to remove the fuser unit.

Warning—Potential Damage: Do not touch the center of the fuser unit. Doing so may cause your fingers to touch the roller underneath the fuser unit. Touching the fuser roller will damage the fuser.

- a Turn the screws on the fuser unit to the left to loosen them.

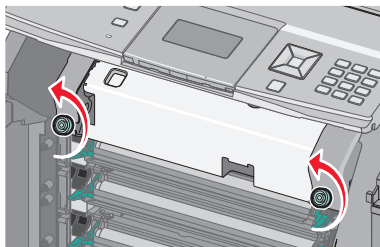

- b** Lift the handholds on each side of the fuser unit, and then pull forward to remove it.

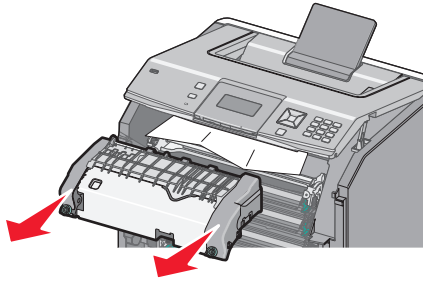

- c** Place the fuser unit on a flat surface.

- 3** Pull the paper gently out of the printer or up toward the standard exit bin to remove it.

- 4** Reinstall the fuser unit.

- a** Align the fuser unit using the handholds on each side, and place it back into the printer.

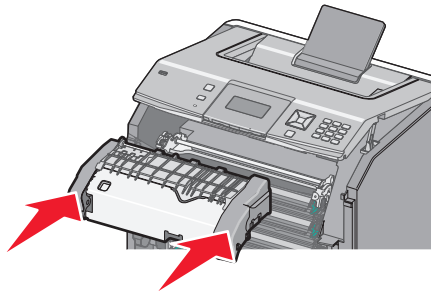

- b** Turn the screws to the right to fasten the fuser unit securely.

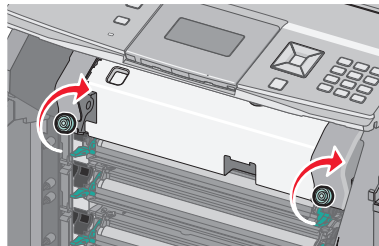

- 5** Close the top cover, and then close the front door.

- 6** Press .

203 and 230 paper jams

- 1 If the jam is in the standard exit bin, grasp the paper and pull it away from the bin.

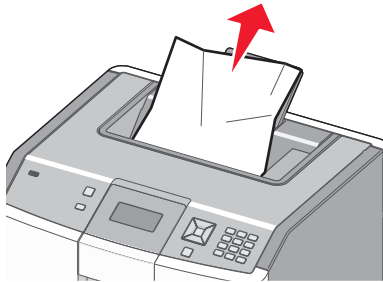

- 2 If the jam is under the rollers near the fuser:

Warning—Potential Damage: To avoid overexposing the photoconductors, do not leave the front door open longer than 10 minutes.

- a Open the front door, and then open the top cover.



CAUTION—HOT SURFACE: The inside of the printer might be hot. To reduce the risk of injury from a hot component, allow the surface to cool before touching.

- b Grasp the paper on each side, and pull it out gently.

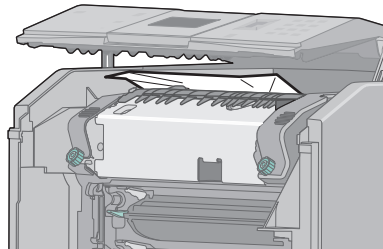

- c Close the top cover, and then close the front door.

- 3 If the jam is between the front door and Tray 1:

- a Remove Tray 1.

- b Open the front door.

Warning—Potential Damage: To avoid overexposing the photoconductors, do not leave the front door open longer than 10 minutes.

- c** Pull straight up to remove the jammed paper.

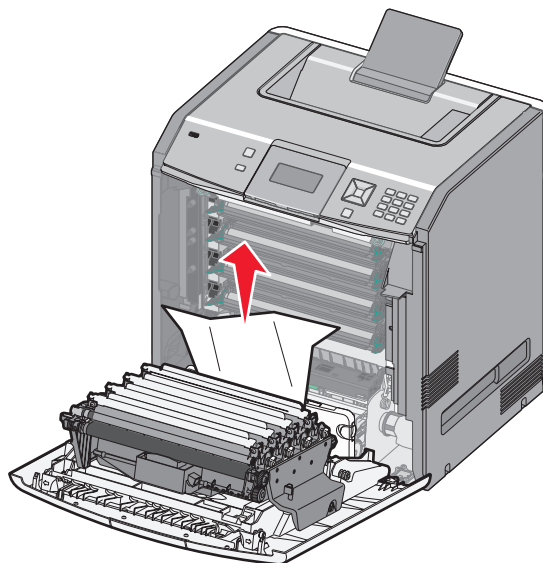

- d** Pull out on the release tabs to allow the front door to split.

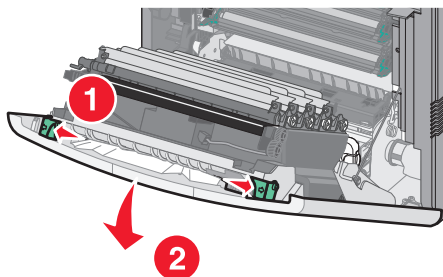

- e** Pull straight out to remove any jammed paper.

- f** Close the front door.

- g** Reinsert Tray 1.

- 4** Press .

24x paper jam

Paper jammed in Tray 1

- 1 Open Tray 1, and then pull the jammed pages straight up and out.

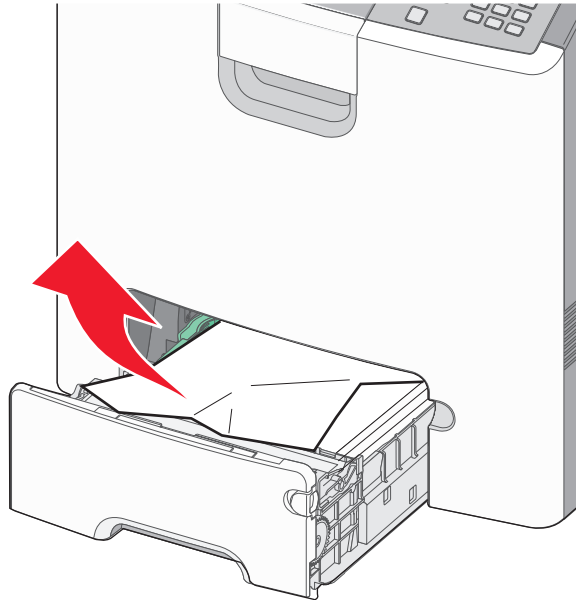

- 2 Close Tray 1.

- 3 Press .

Paper jammed in front of Tray 1

- 1 Open Tray 1, and then pull the jammed pages up and out.

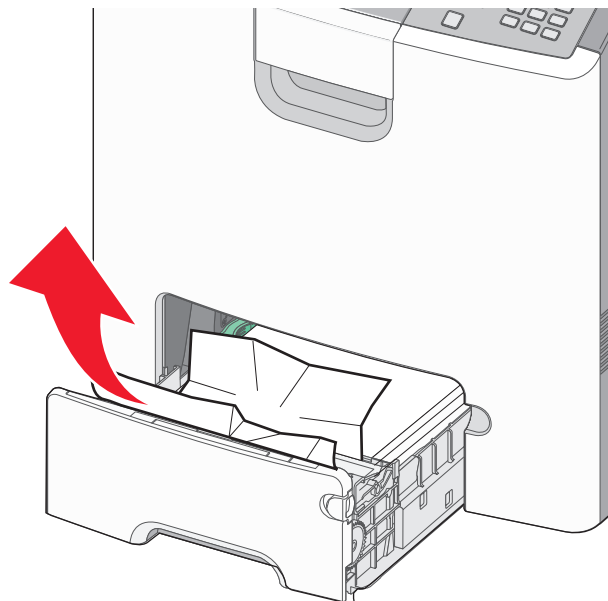

- 2 Close Tray 1.

- 3 Press .

Paper jammed in one of the optional trays

- 1 Open the specified optional tray, and pull the jammed pages out as illustrated.

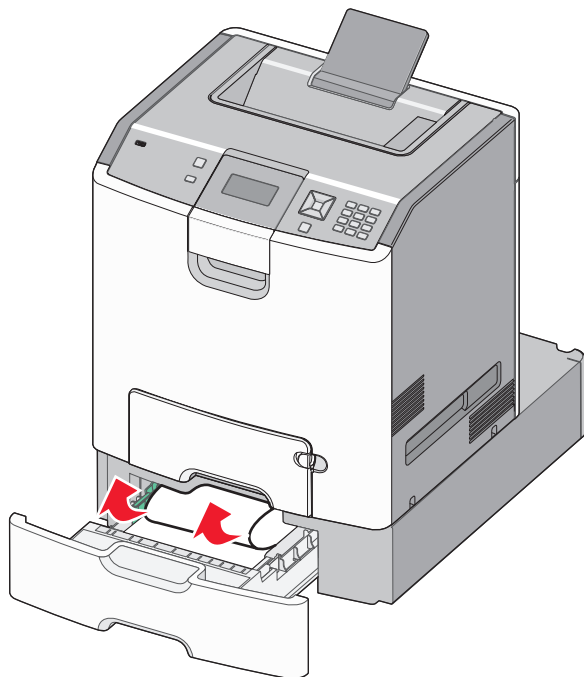

- 2 Close the specified optional tray.

- 3 Press .

250 paper jam

- 1 Press the paper release lever, and then remove the jammed pages from the multipurpose feeder.

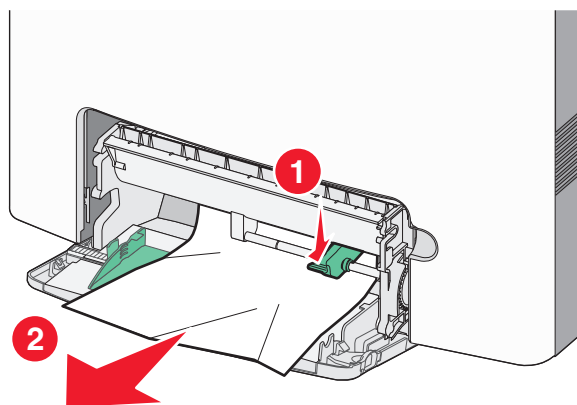

- 2 Load new paper into the multipurpose feeder.

- 3 Press .

Troubleshooting

Understanding printer messages

When **Manual Feeder** appears on the display, it refers to the multipurpose tray, which is also referred to as the multipurpose feeder.

Change <src> to <custom type name>

You can change the current paper source for the remainder of the print job. The formatted page will print on the paper loaded in the selected tray. This may cause clipping of text or images. Try one or more of the following:

- To select the paper tray with the correct paper size or type, press the up or down arrow button until **✓Paper Changed, Continue** appears, and then press .
- To ignore the message and print from the tray selected for the print job, press the up or down arrow button until **✓Use Current <Src>** appears, and then press .
- To cancel the current print job, press the up or down arrow button until **✓Cancel job** appears, and then press .
- For more information, press the up or down arrow button until **✓Show me** or **✓Tell me more** appears, and then press .

Change <src> to <custom string>

You can change the current paper source for the remainder of the print job. The formatted page will print on the paper loaded in the selected tray. This may cause clipping of text or images. Try one or more of the following:

- To select the paper tray with the correct paper size or type, press the up or down arrow button until **✓Paper Changed, Continue** appears, and then press .
- To ignore the message and print from the tray selected for the print job, press the up or down arrow button until **✓Use Current <Src>** appears, and then press .
- To cancel the current print job, press the up or down arrow button until **✓Cancel job** appears, and then press .
- For more information, press the up or down arrow button until **✓Show me** or **✓Tell me more** appears, and then press .

Change <src> to <size>

You can change the current paper source for the remainder of the print job. The formatted page will print on the paper loaded in the selected tray. This may cause clipping of text or images. Try one or more of the following:

- To select the paper tray with the correct paper size or type, press the up or down arrow button until **✓Paper Changed, Continue** appears, and then press .
- To ignore the message and print from the tray selected for the print job, press the up or down arrow button until **✓Use Current <Src>** appears, and then press .

- To cancel the current print job, press the up or down arrow button until **✓Cancel job** appears, and then press .
- For more information, press the up or down arrow button until **✓Show me** or **✓Tell me more** appears, and then press .

Change <src> to <type> <size>

You can change the current paper source for the remainder of the print job. The formatted page will print on the paper loaded in the selected tray. This may cause clipping of text or images. Try one or more of the following:

- To select the paper tray with the correct paper size or type, press the up or down arrow button until **✓Paper Changed, Continue** appears, and then press .
- To ignore the message and print from the tray selected for the print job, press the up or down arrow button until **✓Use Current <Src>** appears, and then press .
- To cancel the current print job, press the up or down arrow button until **✓Cancel job** appears, and then press .
- For more information, press the up or down arrow button until **✓Show me** or **✓Tell me more** appears, and then press .

Close front door

Close the front door to clear the message.

Close top access cover and front door

Close the top access cover and front door to clear the message.

Disk Corrupted

The printer attempted to recover a disk, but was not able to do so. **Format Disk** appears. Press to reformat the disk.

Note: Reformatting the disk deletes all the files currently stored on the disk.

Insert tray <x>

Insert the specified tray into the printer.

Load <src> with <custom type name>

Try one or more of the following:

- Load the specified paper into the specified source to clear the message and continue printing.
- To select the paper tray with the correct paper size or type, press the up or down arrow button until **✓Paper Changed, Continue** appears, and then press .

- Cancel the print job. Press the up or down arrow button until **✓Cancel job** appears, and then press .
- For more information, press the up or down arrow button until **✓Show me** or **✓Tell me more** appears, and then press .

Load <src> with <custom string>

Try one or more of the following:

- Load the specified paper into the specified source to clear the message and continue printing.
- To select the paper tray with the correct paper size or type, press the up or down arrow button until **✓Paper Changed, Continue** appears, and then press .
- Cancel the print job. Press the up or down arrow button until **✓Cancel job** appears, and then press .
- For more information, press the up or down arrow button until **✓Show me** or **✓Tell me more** appears, and then press .

Load <src> with <type> <size>

Try one or more of the following:

- Load the specified paper into the specified source to clear the message and continue printing.
- To select the paper tray with the correct paper size or type, press the up or down arrow button until **✓Paper Changed, Continue** appears, and then press .
- Cancel the print job. Press the up or down arrow button until **✓Cancel job** appears, and then press .
- For more information, press the up or down arrow button until **✓Show me** or **✓Tell me more** appears, and then press .

Load <src> with <size>

Try one or more of the following:

- Load the specified paper into the specified source to clear the message and continue printing.
- To select the paper tray with the correct paper size or type, press the up or down arrow button until **✓Paper Changed, Continue** appears, and then press .
- Cancel the print job. Press the up or down arrow button until **✓Cancel job** appears, and then press .
- For more information, press the up or down arrow button until **✓Show me** or **✓Tell me more** appears, and then press .

Load Manual Feeder with <custom type name>

Try one or more of the following:

- Load the multipurpose feeder with the correct paper type and size.
- Ignore the request and print on paper that is already being used in one of the trays. Press the up or down arrow button until **✓Automatically select paper** appears, and then press .

If the printer finds a tray that has paper of the correct type, then it uses the paper from that tray. If the printer cannot find a tray with the correct paper type, then it prints on the paper that is installed in the default paper source.

- Press the up or down arrow button until **✓Cancel job** appears, and then press to cancel the print job.
- For more information, press the up or down arrow button until **✓Show me** or **✓Tell me more** appears, and then press .

Load Manual Feeder with <custom string>

Try one or more of the following:

- Load the multipurpose feeder with the correct paper type and size.
- Ignore the request and print on paper that is already being used in one of the trays. Press the up or down arrow button until **✓Automatically select paper** appears, and then press .

If the printer finds a tray that has paper of the correct type, then it uses the paper from that tray. If the printer cannot find a tray with the correct paper type, then it prints on the paper that is installed in the default paper source.

- Cancel the print job. Press the up or down arrow button until **✓Cancel job** appears, and then press .
- For more information, press the up or down arrow button until **✓Show me** or **✓Tell me more** appears, and then press .

Load Manual Feeder with <type> <size>

Try one or more of the following:

- Load the correct paper type and size in the multipurpose feeder.
- Ignore the request and print on paper that is already being used in one of the input sources. Press the up or down arrow button until **✓Automatically select paper** appears, and then press . The current job may not print correctly.

If the printer finds a source that has paper of the correct type, then it uses the paper from that source. If the printer cannot find a source with the correct paper type, then it prints on the paper that is installed in the default paper source.

- Cancel the print job. Press the up or down arrow button until **✓Cancel job** appears, and then press .
- For more information, press the up or down arrow button until **✓Show me** or **✓Tell me more** appears, and then press .

Load Manual Feeder with <size>

Try one or more of the following:

- Load the multipurpose feeder with the correct paper size.

If there is no paper in the multipurpose feeder, then feed a sheet of paper to clear the message.

- Ignore the request and print on paper that is already being used in one of the input sources. Press the up or down arrow button until **✓Automatically select paper** appears, and then press .

If the printer finds a source that has paper of the correct type, then it uses the paper from that source. If the printer cannot find a source with the correct paper type, then it prints on the paper that is installed in the default paper source.

- Cancel the print job. Press the up or down arrow button until **✓Cancel job** appears, and then press .
- For more information, press the up or down arrow button until **✓Show me** or **✓Tell me more** appears, and then press .

Remove all color supplies

The printer is set for Color Lock Out printing in the Config menu. Try one of the following methods:

- Remove all color toner cartridges and photoconductor units.
Note: Do *not* remove the black toner cartridge or photoconductor unit.
- Press the up or down arrow button until **✓Continue** appears, and then press to clear the message and print in Color Lock Out mode.

Remove paper from standard output bin

Remove the stack of paper from the standard exit bin.

Remove packaging material, check <area name>

- 1 Remove all packing material from the printer.
- 2 Make sure the fuser, transfer module, trays, and supplies are installed correctly.
- 3 Press the up or down arrow button until **Show Areas** appears, and then press .

Securely clearing disk space

The printer hard disk wiping process needs to recover. The message clears when all blocks are cleared.

Restore Held Jobs?

- Press the up or down arrow button until **✓Restore** appears, and then press to restore all held jobs stored on the printer hard disk.
- Press the up or down arrow button until **✓Do not restore** appears, and then press . No print jobs will be restored.

Some held jobs were not restored

Press the up or down arrow button until **✓Continue** appears, and then press to delete the specified job.

Unsupported disk

An unsupported printer hard disk has been installed. Remove the unsupported device, and then install a supported one.

Unsupported mode, unplug and change mode

Make sure that the camera is in a valid mode for PictBridge.

Unsupported USB hub, please remove

Remove the unrecognized USB hub.

Unsupported USB device, please remove

Remove the unrecognized USB device.

31.yy Missing or defective <color> cartridge

The specified toner cartridge is either missing or not functioning properly.

- Remove the specified toner cartridge, and then reinstall it.
- Remove the specified toner cartridge, and then install a new one.

32.yy <Color> cartridge part number unsupported by device

Remove the specified toner cartridge, and then install a supported one.

34 Short paper

Try one or more of the following:

- Load the appropriate paper in the tray.
- Press the up or down arrow button until **✓Continue** appears, and then press to clear the message and print the job using a different paper tray.
- Check tray length and width guides and make sure the paper is properly loaded in the tray.
- For Windows users, check the Print Properties settings to make sure the print job is requesting the correct paper size and type.

For Macintosh users, check the Print dialog settings to make sure the print job is requesting the correct paper size and type.

- Check that the paper size is correctly set. For example, if the MP Feeder Size is set to Universal, make sure the paper is large enough for the data being printed.
- Cancel the current print job. Press the up or down arrow button until **✓Cancel job** appears, and then press .

35 Insufficient memory to support Resource Save feature

Try one or more of the following:

- Press the up or down arrow button until **✓Continue** appears, and then press to disable Resource Save and continue printing.
- To enable Resource Save after receiving this message, make sure the link buffers are set to Auto, and then exit the menus to activate the link buffer changes. When **Ready** appears, enable Resource Save.

- Install additional memory.

37 Insufficient memory to collate job

Try one or more of the following:

- Press the up or down arrow button until **✓Continue** appears, and then press to print the portion of the job already stored and begin collating the rest of the print job.
- Cancel the current print job. Press the up or down arrow button until **✓Cancel job** appears, and then press .

37 Insufficient memory, some held jobs were deleted

The printer deleted some held jobs in order to process current jobs.

Press the up or down arrow button until **✓Continue** appears, and then press to clear the message.

37 Insufficient memory, some held jobs will not be restored

The printer was unable to restore some or all of the confidential or held jobs on the printer hard disk.

Press the up or down arrow button until **✓Continue** appears, and then press to clear the message.

38 Memory full

Try one or more of the following:

- Press the up or down arrow button until **✓Continue** appears, and then press to clear the message.
- Cancel the current print job. Press the up or down arrow button until **✓Cancel job** appears, and then press .
- Install additional printer memory.

39 Complex page, some data may not have printed

Try one or more of the following:

- Press the up or down arrow button until **✓Continue** appears, and then press to clear the message and continue printing.
- Cancel the current print job. Press the up or down arrow button until **✓Cancel job** appears, and then press .
- Install additional printer memory.

51 Defective flash detected

- Press the up or down arrow button until **✓Continue** appears, and then press to clear the message and continue printing.
- Cancel the current print job.

52 Not enough free space in flash memory for resources

Try one or more of the following:

- Press the up or down arrow button until **✓Continue** appears, and then press to stop the defragment operation and continue printing.
Downloaded fonts and macros not previously stored in flash memory are deleted.
- Delete fonts, macros, and other data stored in flash memory.
- Upgrade to a larger capacity flash memory card.

54 Network <x> software error

- Press the up or down arrow button until **✓Continue** appears, and then press to continue printing.
- Turn the printer off and then back on to reset the printer.
- Upgrade (flash) the network firmware in the printer or print server.

54 Standard network software error

Try one or more of the following:

- Press the up or down arrow button until **✓Continue** appears, and then press to clear the message
- Turn the printer off and then back on to reset the printer.
- Upgrade (flash) the network firmware in the printer or print server.

55 Unsupported option in slot <x>

<x> is a slot on the printer system board.

Try one or more of the following:

- 1 Turn the printer power off.
- 2 Unplug the power cord from the wall outlet.
- 3 Remove the unsupported option card from the printer system board.
- 4 Connect the power cord to a properly grounded outlet.
- 5 Turn the printer power back on.

56 Parallel port <x> disabled

- Press the up or down arrow button until **✓Continue** appears, and then press to clear the message.
The printer discards any data received through the parallel port.
- Make sure the Parallel Buffer menu item is not set to Disabled.

56 Serial port <x> disabled

- Press the up or down arrow button until **✓Continue** appears, and then press to clear the message.
The printer discards any data received through the serial port.
- Make sure the Serial Buffer menu item is not set to Disabled.

56 Standard USB port disabled

Try one or more of the following:

- Press the up or down arrow button until **✓Continue** appears, and then press to clear the message.
The printer discards any data received through the USB port.
- Make sure the USB Buffer menu item is not set to Disabled.

57 Configuration change, held jobs were not restored

Press the up or down arrow button until **✓Continue** appears, and then press to clear the message.

58 Too many disks installed

- 1 Turn the printer off.
- 2 Unplug the power cord from the wall outlet.
- 3 Remove the extra disks.
- 4 Connect the power cord to a properly grounded outlet.
- 5 Turn the printer back on.

58 Too many flash options installed

Too many optional flash memory cards or too many optional firmware cards are installed on the printer.

Try one or more of the following:

- Press the up or down arrow button until **✓Continue** appears, and then press to clear the message and continue printing.
- Remove extra flash options:
 - 1 Turn the printer off.
 - 2 Unplug the power cord from the wall outlet.
 - 3 Remove extra flash options.
 - 4 Connect the power cord to a properly grounded outlet.
 - 5 Turn the printer back on.

58 Too many trays attached

- 1 Turn the printer off.
- 2 Unplug the power cord from the wall outlet.
Note: Optional trays lock together when stacked. Remove stacked trays one at a time from the top down.
- 3 Remove the additional trays.
- 4 Connect the power cord to a properly grounded outlet.
- 5 Turn the printer back on.

59 Incompatible tray <x>

Only options designed specifically for this printer are supported.

Try one or more of the following:

- Remove the specified tray.
- Press the up or down arrow button until **✓Continue** appears, and then press to clear the message and continue printing without using the specified tray.

61 Remove defective hard disk

- Press the up or down arrow button until **✓Continue** appears, and then press to clear the message and continue printing.
- Install a different hard disk before performing any operations that require a hard disk.

62 Disk full

- Press the up or down arrow button until **✓Continue** appears, and then press to clear the message and continue processing.
- Delete fonts, macros, and other data stored on the hard disk.
- Install a larger hard disk.

63 Unformatted disk

- Press the up or down arrow button until **✓Continue** appears, and then press to clear the message and continue printing.
- Format the disk.

If the error message remains, the hard disk may be defective and require replacing.

80.xx Fuser near life warning

- Press the up or down arrow button until **✓Continue** appears, and then press to clear the message and continue printing.
- Order a replacement fuser immediately. When print quality is reduced, install the new fuser using the instruction sheet that came with the replacement part.

80.xx Fuser life warning

- Press the up or down arrow button until **✓Continue** appears, and then press to clear the message and continue printing.
- Order a replacement fuser immediately. When print quality is reduced, install the new fuser using the instruction sheet that came with the replacement part.

80.xx Replace fuser

Replace the fuser using the instruction sheet that came with the replacement part.

80.xx Fuser missing

Reinsert the fuser into the printer.

82.yy Replace waste toner box

The waste toner box is full.

- 1 Replace the waste toner box using the instruction sheet that came with the replacement part.
- 2 Clear the paper path.

82.yy Waste toner box nearly full

Order a replacement waste toner box immediately.

- To learn how to insert a waste toner box, press the up or down arrow button until **Show Me** appears, and then press .
- Press the up or down arrow button until **✓Continue** appears, and then press to clear the message and continue printing.

82.yy Waste toner box missing

Reinsert the waste toner box into the printer.

83.xx Transfer module near life warning

- Press the up or down arrow button until **✓Continue** appears, and then press .
- Order a replacement transfer module immediately. When print quality is reduced, install the new transfer module using the instruction sheet that came with the replacement part.

83.xx Transfer module life warning

- Press the up or down arrow button until **✓Continue** appears, and then press .
- Order a replacement transfer module immediately. When print quality is reduced, install the new transfer module using the instruction sheet that came with the replacement part.

83.xx Replace transfer module

Replace the transfer module using the instruction sheet that came with the replacement part.

83.xx Transfer module missing

Insert the transfer module into the printer.

84.xx <color> photoconductor low

- 1 Press the up or down arrow button until **✓Continue** appears, and then press .
- 2 Order a replacement photoconductor immediately. When print quality is reduced, install the new photoconductor using the instruction sheet that came with the replacement part.

84.xx <color> photoconductor nearly low

- 1 Press the up or down arrow button until **✓Continue** appears, and then press .
- 2 Order a replacement photoconductor immediately. When print quality is reduced, install the new photoconductor using the instruction sheet that came with the replacement part.

84.xx Replace <color> photoconductor

Replace the specified color photoconductor using the instruction sheet that came with the replacement part.

84.xx <color> photoconductor missing

Insert the photoconductor into the printer.

88.yy <color> cartridge low

When this message appears, the toner is low. When the print becomes faded, replace the specified toner cartridge.

To clear this message and continue printing, press the up or down arrow button until **✓Continue** appears, and then press .

88.1x <color> cartridge nearly low

When this message appears, the toner is low. When the print becomes faded, replace the specified toner cartridge.

To clear this message and continue printing, press the up or down arrow button until **✓Continue** appears, and then press .

88.2x Replace <color> cartridge

- 1 The toner cartridge is exhausted. Replace the specified toner cartridge.

Note: To learn how to replace a toner cartridge, press the up or down arrow until **Show Me** appears, and then press .

- 2 Clear the paper path to clear the message and continue printing.

Solving basic problems

Solving basic printer problems

If there are basic printer problems, or the printer is unresponsive, make sure:

- The power cord is plugged into the printer and a properly grounded electrical outlet.
- The electrical outlet is not turned off by any switch or breaker.
- The printer is not plugged into any surge protectors, uninterruptible power supplies, or extension cords.
- Other electronic equipment plugged into the outlet is working.
- The printer is turned on. Check the printer power switch.
- The printer cable is securely attached to the printer and the host computer, print server, option, or other network device.
- All options are properly installed.
- The printer driver settings are correct.

Once you have checked each of these possibilities, turn the printer off, wait for about 10 seconds, and then turn the printer back on. This often fixes the problem.

Embedded Web Server does not open

These are possible solutions. Try one or more of the following:

CHECK THE NETWORK CONNECTIONS

Make sure the printer and computer are turned on and connected to the same network.

CHECK THE NETWORK SETTINGS

Depending on the network settings, you may need to type **https://** instead of **http://** before the printer IP address to access the Embedded Web Server. For more information, see your system administrator.

Solving printing problems

Multiple-language PDFs do not print

The documents contain unavailable fonts.

- 1 Open the document you want to print in Adobe Acrobat.
- 2 Click the printer icon.
The Print dialog appears.
- 3 Select **Print as image**.
- 4 Click **OK**.

Printer control panel display is blank or displays only diamonds

The printer self test failed. Turn the printer off, wait about 10 seconds, and then turn the printer back on.

If the clock graphic and **Ready** do not appear, then turn the printer off and contact Customer Support.

Error message about reading USB drive appears

Make sure the USB drive is supported. For information regarding tested and approved USB flash memory devices, see “Printing from a flash drive” on page 71.

Jobs do not print

These are possible solutions. Try one or more of the following:

MAKE SURE THE PRINTER IS READY TO PRINT

Make sure **Ready** or **Power Saver** appears on the display before sending a job to print.

CHECK TO SEE IF THE STANDARD EXIT BIN IS FULL

Remove the stack of paper from the standard exit bin.

CHECK TO SEE IF THE PAPER TRAY IS EMPTY

Load paper in the tray.

MAKE SURE THE CORRECT PRINTER SOFTWARE IS INSTALLED

- Verify that you are using the correct printer software.
- If you are using a USB port, make sure you are running a supported operating system and using compatible printer software.

MAKE SURE THE INTERNAL PRINT SERVER IS INSTALLED PROPERLY AND WORKING

- Make sure the internal print server is properly installed and that the printer is connected to the network. For more information about installing a network printer, click **View User's Guide and Documentation** on the *Software and Documentation* CD.
- Print a network setup page and check that the status shows **Connected**. If the status is **Not Connected**, check the network cables, and then try printing the network setup page again. Contact your system support person to make sure the network is functioning correctly.

Copies of the printer software are also available on the Lexmark Web site at www.lexmark.com.

MAKE SURE YOU ARE USING A RECOMMENDED PRINTER CABLE

For more information, visit the Lexmark Web site at www.lexmark.com.

MAKE SURE PRINTER CABLES ARE SECURELY CONNECTED

Check the cable connections to the printer and print server to make sure they are secure.

For more information, see the setup documentation that came with the printer.

Confidential and other held jobs do not print

These are possible solutions. Try one or more of the following:

PARTIAL JOB, NO JOB, OR BLANK PAGE PRINTS

The print job may contain a formatting error or invalid data.

- Delete the print job, and then print it again.
- For PDF documents, recreate the PDF and then print it again.

If you are printing from the Internet, then the printer may be reading multiple job titles as duplicates and deleting all jobs except the first one.

- For Windows users, open Print Properties. From the Print and Hold dialog, select the "Keep duplicate documents" check box under the User name text box before entering a PIN number.
- For Macintosh users, save each print job, naming each job differently, and then send the individual jobs to the printer.

MAKE SURE THE PRINTER HAS SUFFICIENT MEMORY

Free up additional printer memory by scrolling through the list of held jobs and deleting some of them.







Job takes longer than expected to print

These are possible solutions. Try one or more of the following:

REDUCE THE COMPLEXITY OF THE PRINT JOB

Eliminate the number and size of fonts, the number and complexity of images, and the number of pages in the job.

CHANGE THE PAGE PROTECT SETTING TO OFF

- 1 From the printer control panel, press .
- 2 Press the up or down arrow button until **√Settings** appears, and then press .
- 3 Press the up or down arrow button until **√General Settings** appears, and then press .
- 4 Press the up or down arrow button until **√Print Recovery** appears, and then press .
- 5 Press the up or down arrow button until **√Page Protect** appears, and then press .
- 6 Press the up or down arrow button until **√Off** appears, and then press .

Job prints from the wrong tray or on the wrong paper

CHECK THE PAPER TYPE SETTING

Make sure the paper type setting matches the paper loaded in the tray:

- 1 From the printer control panel Paper menu, check the Paper Type setting.
- 2 Before sending the job to print, specify the correct type setting:
 - For Windows users, specify the type from Print Properties.
 - For Macintosh users, specify the type from the Print dialog.

Incorrect characters print

MAKE SURE THE PRINTER IS NOT IN HEX TRACE MODE

If **Ready Hex** appears on the display, then you must exit Hex Trace mode before you can print your job. Turn the printer off and back on to exit Hex Trace mode.

Tray linking does not work

These are possible solutions. Try one or more of the following:

LOAD THE SAME SIZE AND TYPE OF PAPER

- Load the same size and type of paper in each tray to be linked.
- Move the paper guides to the correct positions for the paper size loaded in each tray.

USE THE SAME PAPER SIZE AND PAPER TYPE SETTINGS

- Print a menu settings page and compare the settings for each tray.
- If necessary, adjust the settings from the Paper Size/Type menu.

Note: The standard 550-sheet tray and the multipurpose feeder do not automatically sense the paper size. You must set the size from the Paper Size/Type menu.

Large jobs do not collate

These are possible solutions. Try one or more of the following:

MAKE SURE COLLATE IS SET TO ON

From the Finishing menu or Print Properties, set Collate to On.

Note: Setting Collate to Off in the software overrides the setting in the Finishing menu.

REDUCE THE COMPLEXITY OF THE PRINT JOB







Reduce the complexity of the print job by eliminating the number and size of fonts, the number and complexity of images, and the number of pages in the job.

MAKE SURE THE PRINTER HAS ENOUGH MEMORY

Add printer memory or an optional hard disk.

Unexpected page breaks occur

Increase the Print Timeout value:

- 1 From the printer control panel, press .
- 2 Press the up or down arrow button until **Settings** appears, and then press .
- 3 Press the up or down arrow button until **General Settings** appears, and then press .
- 4 Press the up or down arrow button until **Timeouts** appears, and then press .
- 5 Press the up or down arrow button until **Print Timeout** appears, and then press .
- 6 Press the up or down arrow button until the value you want appears, and then press .

Solving option problems

Settings chosen from the software program or application can change or override settings chosen from the printer control panel. If an option is not functioning, then make sure it is selected in the software as well as the printer control panel.

Option does not operate correctly or quits after it is installed

These are possible solutions. Try one or more of the following:

RESET THE PRINTER

Turn the printer off, wait for about 10 seconds, and then turn the printer on.

CHECK TO SEE IF THE OPTION IS CONNECTED TO THE PRINTER

- 1 Turn the printer off.
- 2 Unplug the printer.
- 3 Check the connection between the option and the printer.

MAKE SURE THE OPTION IS INSTALLED

Print a menu settings page and check to see if the option is listed in the Installed Options list. If the option is not listed, reinstall it.

MAKE SURE THE OPTION IS AVAILABLE IN THE PRINTER DRIVER

It may be necessary to manually add the option in the printer driver to make it available for print jobs. For more information, see "Updating available options in the printer driver" on page 35.

MAKE SURE THE OPTION IS SELECTED

From the program you are using, select the option. Mac OS 9 users should make sure the printer is set up in the Chooser.

Paper trays

These are possible solutions. Try one or more of the following:

MAKE SURE THE PAPER IS LOADED CORRECTLY

- 1 Open the paper tray.
- 2 Check for paper jams or misfeeds.
- 3 Make sure paper guides are aligned against the edges of the paper.
- 4 Make sure the paper tray closes properly.

RESET THE PRINTER

Turn the printer off, wait about 10 seconds, and then turn the printer on.

MAKE SURE THE PAPER TRAY IS INSTALLED CORRECTLY

If the paper tray is listed on the menu settings page, but paper jams when it enters or exits the tray, then it may not be properly installed. Reinstall the paper tray. For more information, see the hardware setup documentation that came with the paper tray, or go to <http://support.lexmark.com> to view the paper tray instruction sheet.

Solving 2,000-sheet drawer problems

Try one or more of the following:

THE ELEVATOR TRAY IS NOT WORKING PROPERLY

- Make sure the printer is properly connected to the 2,000-sheet drawer.
- Make sure the printer is turned on.
- Make sure that the power cord is plugged firmly into the back of the 2,000-sheet drawer.
- If the tray is empty, then load paper in the tray.
- Clear any jams.

THE PAPER FEED ROLLERS DO NOT TURN TO ADVANCE PAPER

- Make sure the printer is properly connected to the 2,000-sheet drawer.
- Make sure the printer is turned on.

THE PAPER CONSISTENTLY JAMS IN THE DRAWER

- Flex the paper.
- Make sure the drawer is properly installed.
- Make sure paper is loaded correctly.
- Make sure the paper or specialty media meets specifications and is not damaged.
- Make sure the guides are positioned correctly for the paper size loaded.

Memory card

Make sure the memory card is securely connected to the printer system board.

Flash memory card

Make sure the flash memory card is securely connected to the printer system board.

Hard disk with adapter

Make sure the hard disk is securely connected to the printer system board.

Internal Solutions Port

If the Lexmark Internal Solutions Port (ISP) does not operate correctly, then these are possible solutions. Try one or more of the following:

CHECK THE ISP CONNECTIONS

- Make sure the ISP is securely attached to the printer system board.
- Make sure the cable is securely connected to the correct connector.

CHECK THE CABLE

Make sure you are using the correct cable and that it is securely connected.

MAKE SURE THE NETWORK SOFTWARE IS CONFIGURED CORRECTLY

For information about installing software for network printing, see the *Networking Guide* on the *Software and Documentation CD*.

Internal print server

If the internal print server does not operate correctly, these are possible solutions. Try one or more of the following:

CHECK THE PRINT SERVER CONNECTIONS

- Make sure the internal print server is attached securely to the printer system board.
- Make sure you are using the correct (optional) cable and that it is securely connected.

MAKE SURE THE NETWORK SOFTWARE IS CONFIGURED CORRECTLY

For information about installing software for network printing, click **Additional** on the *Software and Documentation CD*, and then select the **Networking Guide** link under **Publications on this CD**.

USB/parallel interface card

Check the USB/parallel interface card connections:

- Make sure the USB/parallel interface card is securely connected to the printer system board.
- Make sure you are using the correct cable and that it is securely connected.

Solving paper feed problems

Paper frequently jams

These are possible solutions. Try one or more of the following:

CHECK THE PAPER

Use recommended paper and specialty media. For more information, see the chapter about paper and specialty media guidelines.

MAKE SURE THERE IS NOT TOO MUCH PAPER IN THE PAPER TRAY

Make sure the stack of paper you load does not exceed the maximum stack height indicated in the tray or on the multipurpose feeder.

CHECK THE PAPER GUIDES

Move the guides in the tray to the correct positions for the paper size loaded.

THE PAPER MAY HAVE ABSORBED MOISTURE DUE TO HIGH HUMIDITY

- Load paper from a fresh package.
- Store paper in its original wrapper until you use it.

Paper jam message remains after jam is cleared

- 1 Clear jammed paper from the entire paper path.
- 2 Press the up or down arrow button until **✓Continue** appears, and then press .

Page that jammed does not reprint after you clear the jam

Jam Recovery is set to Off. Set Jam Recovery to Auto or On:

- 1 Press .
- 2 Press the up or down arrow button until **✓Settings** appears, and then press .
- 3 Press the up or down arrow button until **✓General Settings** appears, and then press .
- 4 Press the up or down arrow button until **✓Print Recovery** appears, and then press .
- 5 Press the up or down arrow button until **✓Jam Recovery** appears, and then press .
- 6 Press the up or down arrow button until **✓On** or **✓Auto** appears, and then press .

Solving print quality problems

The information in the following topics may help you solve print quality problems. If these suggestions do not correct the problem, contact Customer Support. You may have a printer part that requires adjustment or replacement.

Isolating print quality problems

To help isolate print quality problems, print the print quality test pages:

- 1 Make sure paper is loaded in Tray 1.
- 2 Turn the printer off.
- 3 From the printer control panel, press and hold and the right arrow button while turning the printer on.
- 4 Release both buttons when the clock appears, and wait for **Config Menu** to appear.
- 5 Press the up or down arrow button until **✓Prt Quality Pgs** appears, and then press .
The print quality test pages print.
- 6 Press the up or down arrow button until **✓Exit Config Menu** appears, and then press .
Resetting the Printer appears briefly, followed by a clock, and then **Ready** appears.

Blank pages

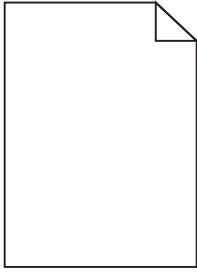

These are possible solutions. Try one or more of the following:

PACKING MATERIAL MAY BE ON THE TONER CARTRIDGE

Remove the toner cartridge and make sure the packing material is properly removed. Reinstall the toner cartridge.

THE TONER MAY BE LOW

Remove the toner cartridge from the printer. Shake the cartridge back and forth several times, and then reinstall it. If necessary, install a new toner cartridge.

THE TONER CARTRIDGE MAY BE DEFECTIVE OR EMPTY

Replace the toner cartridge.

If the problem continues, the printer may need to be serviced. For more information, contact Customer Support.

Characters have jagged or uneven edges

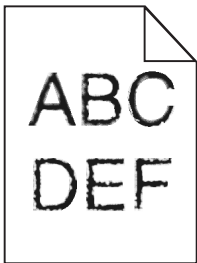

If you are using downloaded fonts, verify that the fonts are supported by the printer, the host computer, and the software program.



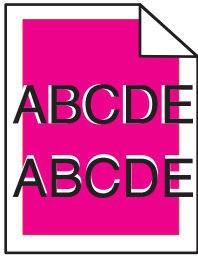







Color misregistration



Color has shifted outside of the appropriate area or has been superimposed over another color area. Try the following:

- 1 Recalibrate the printer.
Perform Color Adjust from the Quality menu.
- 2 Remove and reinstall the photoconductor.
- 3 Adjust the color alignment. For more information, see “Adjusting the color alignment” on page 179.
Note: If you have not resolved the issue, then recalibrate again. If necessary, adjust the color alignment again.

Adjusting the color alignment

- 1 Make sure that the printer is turned off.
- 2 From the printer control panel, press and hold  and the right arrow button while turning the printer on.
- 3 Release both buttons when the clock appears.
The printer performs its power-on sequence, and then **Config Menu** appears.
- 4 Press the up or down arrow button until  **Color Alignment** appears, and then press .
- 5 Press  again to print the alignment page.
- 6 Press the up or down arrow button until  **Set A** appears, and then press .
- 7 From the printed sheet, find the straightest of the 20 lines beside the letter A.
- 8 Press the left or right arrow button until that number is displayed, and then press .
- Submitting selection** appears.
- 9 Repeat steps 6 through 8 to align sets A through L.
- 10 Press .
- 11 Press .
- 12 Press the up or down arrow button until  **Exit Config Menu** appears, and then press .
- Resetting the Printer** appears briefly, followed by a clock, and then **Ready** appears.

Clipped images

Try one or more of the following:

CHECK THE GUIDES

Move the width and length guides in the tray to the correct positions for the paper size loaded.

CHECK THE PAPER SIZE SETTING

Make sure the paper size setting matches the paper loaded in the tray:

- 1 From the printer control panel Paper menu, check the Paper Size setting.
- 2 Before sending the job to print, specify the correct size setting:
 - For Windows users, specify the size from Print Properties.
 - For Macintosh users, specify the size from the Page Setup dialog.

Fine horizontal lines appear on color pages

You may notice fine, horizontal lines in photographs or pages with a high concentration of color. This can occur when the printer is in Quiet Mode. To fix this, set Quiet Mode to **Off (Image/Photo)**.

Ghost images



CHECK THE PAPER TYPE AND WEIGHT SETTINGS

Make sure the paper type and weight settings match the paper loaded in the tray:

- 1 From the printer control panel Paper menu, check the Paper Type and Paper Weight settings.
- 2 Before sending the job to print, specify the correct type setting:
 - For Windows users, specify the type from Print Properties.
 - For Macintosh users, specify the type from the Print dialog.

THE PHOTOCONDUCTOR MAY BE DEFECTIVE

Replace the photoconductor.

THE TONER MAY BE LOW

Replace the toner cartridge.

Gray background

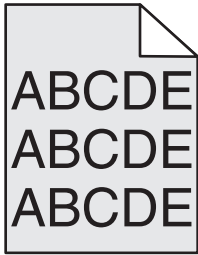

CHECK THE TONER DARKNESS SETTING

Select a lighter Toner Darkness setting:

- From the printer control panel Quality menu, change the setting.
- For Windows users, change the setting from Print Properties.
- For Macintosh users, change the setting from the Print dialog.

THE TONER CARTRIDGE MAY BE WORN OR DEFECTIVE

Replace the toner cartridge.

Incorrect margins

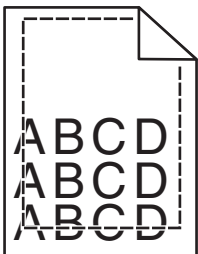

These are possible solutions. Try one or more of the following:

CHECK THE PAPER GUIDES

Move the guides in the tray to the correct positions for the paper size loaded.

CHECK THE PAPER SIZE SETTING

Make sure the paper size setting matches the paper loaded in the tray:

- 1 From the printer control panel Paper menu, check the Paper Size setting.
- 2 Before sending the job to print, specify the correct size setting:
 - For Windows users, specify the size from Print Properties.
 - For Macintosh users, specify the size from the Page Setup dialog.

Light colored line, white line, or incorrectly colored line

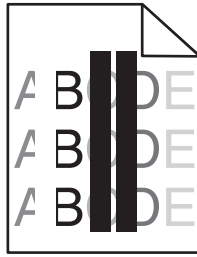

These are possible solutions. Try one or more of the following:

A TONER CARTRIDGE IS DEFECTIVE

Replace the defective toner cartridge.

A PHOTOCONDUCTOR IS DEFECTIVE

Replace the defective photoconductor.

THE TRANSFER MODULE IS DEFECTIVE

Replace the transfer module.

THE PRINTHEAD LENSES ARE DIRTY

Clean the printhead lenses.

Paper curl

These are possible solutions. Try one or more of the following:

CHECK THE PAPER TYPE AND WEIGHT SETTINGS

Make sure the paper type and weight settings match the paper loaded in the tray:

- 1 From the printer control panel Paper menu, check the Paper Type and Paper Weight settings.
- 2 Before sending the job to print, specify the correct type setting:
 - For Windows users, specify the type from Print Properties.
 - For Macintosh users, specify the type from the Print dialog.

THE PAPER MAY HAVE ABSORBED MOISTURE DUE TO HIGH HUMIDITY

- Load paper from a fresh package.
- Store paper in its original wrapper until you use it.

Print irregularities

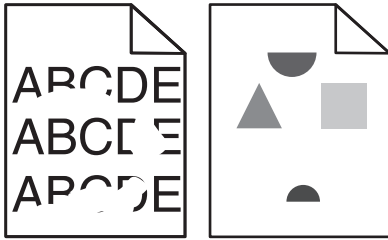

These are possible solutions. Try one or more of the following:

THE PAPER MAY HAVE ABSORBED MOISTURE DUE TO HIGH HUMIDITY

Load paper from a fresh package.

CHECK THE PAPER TYPE AND WEIGHT SETTINGS

Make sure the paper type and weight settings match the paper loaded in the tray:

- 1 From the printer control panel Paper menu, check the Paper Type and Paper Weight settings.
- 2 Before sending the job to print, specify the correct type setting:
 - For Windows users, specify the type from Print Properties.
 - For Macintosh users, specify the type from the Print dialog.

CHECK THE PAPER

Avoid textured paper with rough finishes.

THE TONER CARTRIDGE, THE TRANSFER MODULE, OR THE FUSER MAY BE WORN OR DEFECTIVE

Replace the toner cartridge, the transfer module, or the fuser.

Print is too dark

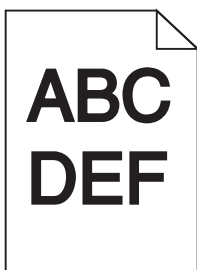

These are possible solutions. Try one or more of the following:

RECALIBRATE THE PRINTER

Perform Color Adjust from the printer control panel Quality menu.

CHECK THE DARKNESS, BRIGHTNESS, AND CONTRAST SETTINGS

The Toner Darkness setting is too dark, the RGB Brightness setting is too dark, or the RGB Contrast setting is too high.

- Change these settings from the printer control panel Quality menu.
- For Windows users, change these settings from Print Properties.
- For Macintosh users, change these settings from the Print dialog and pop-up menus.

THE TONER CARTRIDGE MAY BE WORN OR DEFECTIVE

Replace the toner cartridge.

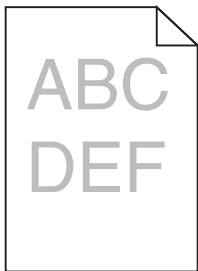
Print is too light

These are possible solutions. Try one or more of the following:

RECALIBRATE THE PRINTER

Perform Color Adjust from the printer control panel Quality menu.

CHECK THE DARKNESS, BRIGHTNESS, AND CONTRAST SETTINGS

The Toner Darkness setting is too light, the RGB Brightness setting is too light, or the RGB Contrast setting is too low.

- Change these settings from the printer control panel Quality menu.
- For Windows users, change these settings from Print Properties.
- For Macintosh users, change these settings from the Print dialog and pop-up menus.

THE PAPER MAY HAVE ABSORBED MOISTURE DUE TO HIGH HUMIDITY

Load paper from a fresh package.

CHECK THE PAPER

Avoid textured paper with rough finishes.

CHECK THE PAPER TYPE AND WEIGHT SETTINGS

Make sure the paper type and weight settings match the paper loaded in the tray:

- 1 From the printer control panel Paper menu, check the Paper Type and Paper Weight settings.
- 2 Before sending the job to print, specify the correct type setting:
 - For Windows users, specify the type from Print Properties.
 - For Macintosh users, specify the type from the Print dialog.

COLOR SAVER MAY BE SET TO ON

Turn Color Saver off in the printer control panel Quality menu.

THE TONER MAY BE LOW

Replace the toner cartridge.

THE TONER CARTRIDGE MAY BE WORN OR DEFECTIVE

Replace the toner cartridge.

Repeating defects

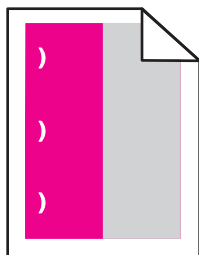

These are possible solutions. Try one or more of the following:

Replace the toner cartridge if the defects occur every:

- 33.0 mm (1.30 in.)
- 35.3 mm (1.39 in.)

Replace the photoconductor if the defects occur every:

- 28.3 mm (1.11 in.)
- 72.4 mm (2.85 in.)

Replace the fuser if the defects occur every:

- 47.4 mm (1.87 in.)
- 94.8 mm (3.73 in.)
- 113.0 mm (4.45 in.)

Skewed print

These are possible solutions. Try one or more of the following:

CHECK THE PAPER GUIDES

Move the length and width guides in the tray to the correct positions for the paper size loaded.

- Make sure the guides are not too far from the paper stack.
- Make sure the guides are not pressing too lightly against the paper stack.

CHECK THE PAPER

Make sure you are using paper that meets the printer specifications.

Solid color pages



These are possible solutions. Try one or more of the following:

THE PHOTOCONDUCTOR MAY BE DEFECTIVE OR INSTALLED INCORRECTLY

Remove and then reinstall the photoconductor. If the problem continues, the photoconductor may need to be replaced.

THE TONER CARTRIDGE MAY BE DEFECTIVE OR LOW ON TONER

Remove the toner cartridge and shake it from side to side to redistribute the toner, and then reinstall it. If the problem continues, replace the used toner cartridge with a new one. The printer may also need to be serviced. For more information, contact Customer Support.

Streaked horizontal lines

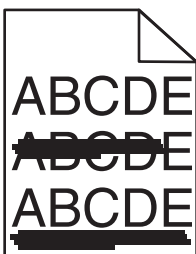

These are possible solutions. Try one or more of the following:

THE TONER CARTRIDGE MAY BE WORN, DEFECTIVE, OR EMPTY

Replace the toner cartridge.

THE FUSER MAY BE DEFECTIVE

Replace the fuser.

THE PHOTOCONDUCTOR MAY BE DEFECTIVE

Replace the photoconductor.

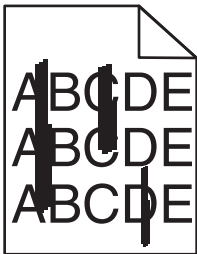
Streaked vertical lines

These are possible solutions. Try one or more of the following:

THE TONER MAY HAVE SMEARED

Select another tray or feeder to feed paper for the job:

- From the printer control panel Paper Menu, select the Default Source.
- For Windows users, select the paper source from Print Properties.
- For Macintosh users, select the paper source from the Print dialog and pop-up menus.

THE TONER CARTRIDGE MAY BE DEFECTIVE

Replace the toner cartridge.

THE TRANSFER MODULE MAY BE WORN OR DEFECTIVE

Replace the transfer module.

Toner fog or background shading appears on the page

These are possible solutions. Try one or more of the following:

THE TONER CARTRIDGE MAY BE DEFECTIVE OR INSTALLED INCORRECTLY

Reinstall or replace the toner cartridge.

THE TRANSFER MODULE MAY BE WORN OR DEFECTIVE

Replace the transfer module.

THE PHOTOCONDUCTOR MAY BE WORN OR DEFECTIVE

Replace the photoconductor.

THE FUSER MAY BE WORN OR DEFECTIVE

Replace the fuser.

THERE IS TONER IN THE PAPER PATH

The printer may need to be serviced. For more information, contact Customer Support.

RECALIBRATE THE PRINTER

Perform color adjust from the printer control panel Quality menu.

CHECK THE SOFTWARE PROGRAM OR APPLICATION

The software program or application may have specified off-white background.

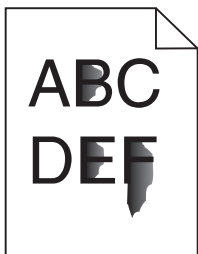
Toner rubs off

These are possible solutions. Try one or more of the following:

CHECK THE PAPER TYPE AND WEIGHT SETTINGS

Make sure the paper type and weight settings match the paper loaded in the tray:

- 1 From the printer control panel Paper menu, check the Paper Type and Paper Weight settings. Change the Paper Weight setting from Normal to Heavy.
- 2 Before sending the job to print, specify the correct type setting:
 - For Windows users, specify the type from Print Properties.
 - For Macintosh users, specify the type from the Print dialog.

CHECK THE PAPER TEXTURE SETTING

From the printer control panel Paper menu, make sure the Paper Texture setting matches the paper loaded in the tray. If necessary, change the Paper Texture setting from Normal to Rough.

THE FUSER MAY BE WORN OR DEFECTIVE

Replace the fuser.

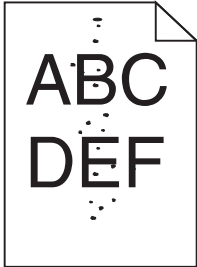
Toner specks

These are possible solutions. Try one or more of the following:

THE TONER CARTRIDGE MAY BE WORN OR DEFECTIVE

Replace the toner cartridge.

THERE IS TONER IN THE PAPER PATH

The printer may need to be serviced. For more information, contact Customer Support.

THE PHOTOCONDUCTOR MAY BE DEFECTIVE

Replace the photoconductor.

Transparency print quality is poor

Try one or more of the following:

CHECK THE TRANSPARENCIES

Use only transparencies that meet the printer specifications.

CHECK THE PAPER TYPE SETTING

Make sure the paper type setting is set to Transparency:

- 1 From the printer control panel Paper menu, check the Paper Type setting.
- 2 Before sending the job to print, specify the correct type setting:
 - For Windows users, specify the type from Print Properties.
 - For Macintosh users, specify the type from the Print dialog.

Uneven print density

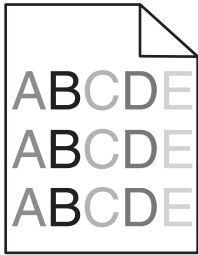

These are possible solutions. Try one or more of the following:

A TONER CARTRIDGE MAY BE WORN OR DEFECTIVE

Replace the worn or defective toner cartridge.

A PHOTOCONDUCTOR MAY BE DEFECTIVE

Replace the defective photoconductor.

Solving color quality problems

This section helps answer some basic color-related questions and describes how some of the features provided in the Quality Menu can be used to solve typical color problems.

FAQ about color printing

What is RGB color?

Red, green, and blue light can be added together in various amounts to produce a large range of colors observed in nature. For example, red and green can be combined to create yellow. Televisions and computer monitors create colors in this manner. RGB color is a method of describing colors by indicating the amount of red, green, or blue needed to produce a certain color.

What is CMYK color?

Cyan, magenta, yellow, and black inks or toners can be printed in various amounts to produce a large range of colors observed in nature. For example, cyan and yellow can be combined to create green. Printing presses, inkjet printers, and color laser printers create colors in this manner. CMYK color is a method of describing colors by indicating the amount of cyan, magenta, yellow, and black needed to reproduce a particular color.

How is color specified in a document to be printed?

Software programs typically specify document color using RGB or CMYK color combinations. Additionally, they allow users to modify the color of each object in a document. For more information, see the software program Help topics.

How does the printer know what color to print?

When a user prints a document, information describing the type and color of each object is sent to the printer. The color information is passed through color conversion tables that translate the color into the appropriate amounts of cyan, magenta, yellow, and black toner needed to produce the desired color. The object information determines the application of color conversion tables. For example, it is possible to apply one type of color conversion table to text while applying a different color conversion table to photographic images.

Should I use PostScript or PCL emulation printer software? What settings should I use for the best color?

The PostScript driver is strongly recommended for best color quality. The default settings in the PostScript driver provide the preferred color quality for the majority of printouts.

Why doesn't the printed color match the color I see on the computer screen?

The color conversion tables used in Auto Color Correction mode generally approximate the colors of a standard computer monitor. However, because of technology differences that exist between printers and monitors, there are many colors that can also be affected by monitor variations and lighting conditions. For recommendations on how the printer color sample pages may be useful in solving certain color-matching problems, see the question, "How can I match a particular color (such as a corporate logo)?"

The printed page appears tinted. Can I adjust the color?

Sometimes a printed page may appear tinted (for example, everything printed seems to be too red). This can be caused by environmental conditions, paper type, lighting conditions, or user preference. In these instances, adjust the Color Balance setting to create a more preferable color. Color Balance provides the user with the ability to make subtle adjustments to the amount of toner being used in each color plane. Selecting positive or negative values for cyan, magenta, yellow, and black (from the Color Balance menu) will slightly increase or decrease the amount of toner used for the chosen color. For example, if a printed page has a red tint, then decreasing both magenta and yellow could potentially improve the color balance.

My color transparencies seem dark when they are projected. Is there anything I can do to improve the color?

This problem most commonly occurs when projecting transparencies with reflective overhead projectors. To obtain the highest projected color quality, transmissive overhead projectors are recommended. If a reflective projector must be used, then adjusting the Toner Darkness setting to 1, 2, or 3 will lighten the transparency. Make sure to print on the recommended type of color transparencies.

What is manual color correction?

When manual color correction is enabled, the printer employs user-selected color conversion tables to process objects. However, Color Correction must be set to Manual, or no user-defined color conversion will be implemented. Manual color correction settings are specific to the type of object being printed (text, graphics, or images), and how the color of the object is specified in the software program (RGB or CMYK combinations).

Notes:

- Manual color correction is not useful if the software program does not specify colors with RGB or CMYK combinations. It is also not effective in situations in which the software program or the computer operating system controls the adjustment of colors.
- The color conversion tables—applied to each object when Color Correction is set to Auto—generate preferred colors for the majority of documents.

To manually apply a different color conversion table:

- 1** From the Quality menu, select **Color Correction**, and then select **Manual**.
- 2** From the Quality menu, select **Manual Color**, and then select the appropriate color conversion table for the affected object type.

Manual Color menu

Object type	Color conversion tables
RGB Image RGB Text RGB Graphics	<ul style="list-style-type: none"> • Vivid—Produces brighter, more saturated colors and may be applied to all incoming color formats. • sRGB Display—Produces an output that approximates the colors displayed on a computer monitor. Black toner usage is optimized for printing photographs. • Display—True Black—Produces an output that approximates the colors displayed on a computer monitor. Uses only black toner to create all levels of neutral gray. • sRGB Vivid—Provides an increased color saturation for the sRGB Display color correction. Black usage is optimized for printing business graphics. • Off—No color correction is implemented.
CMYK Image CMYK Text CMYK Graphics	<ul style="list-style-type: none"> • US CMYK—Applies color correction to approximate the SWOP (Specifications for Web Offset Publishing) color output. • Euro CMYK—Applies color correction to approximated EuroScale color output. • Vivid CMYK—Increases the color saturation of the US CMYK color correction setting. • Off—No color correction is implemented.

How can I match a particular color (such as a corporate logo)?

From the printer Quality menu, nine types of Color Samples sets are available. These are also available from the Color Samples page of the Embedded Web Server. Selecting any sample set generates a multiple-page printout consisting of hundreds of colored boxes. Either a CMYK or RGB combination is located on each box, depending on the table selected. The observed color of each box is obtained by passing the CMYK or RGB combination labeled on the box through the selected color conversion table.

By examining Color Samples sets, a user can identify the box whose color is the closest to the desired color. The color combination labeled on the box can then be used for modifying the color of the object in a software program. For more information, see the software program Help topics. Manual color correction may be necessary to utilize the selected color conversion table for the particular object.

Selecting which Color Samples set to use for a particular color-matching problem depends on the Color Correction setting being used (Auto, Off, or Manual), the type of object being printed (text, graphics, or images), and how the color of the object is specified in the software program (RGB or CMYK combinations). When the printer Color Correction setting is set to Off, the color is based on the print job information; and no color conversion is implemented.

Note: The Color Samples pages are not useful if the software program does not specify colors with RGB or CMYK combinations. Additionally, certain situations exist in which the software program or the computer operating system adjusts the RGB or CMYK combinations specified in the program through color management. The resulting printed color may not be an exact match of the Color Samples pages.

What are detailed Color Samples and how do I access them?

Detailed Color Samples sets are available only through the Embedded Web Server of a network printer. A detailed Color Samples set contains a range of shades (displayed as colored boxes) that are similar to a user-defined RGB or CMYK value. The likeness of the colors in the set are dependent on the value entered in the RGB or CMYK Increment box.

To access a detailed Color Samples set from the Embedded Web Server:

- 1 Type the printer IP address into the address field of your Web browser.

Note: If you do not know the IP address of the printer, then print a network setup page and locate the IP address in the TCP/IP section.

- 2 Click **Configuration**.
- 3 Click **Color Samples**.
- 4 Click **Detailed Options** to narrow the set to one color range.
- 5 When the Detailed Options page appears, select a color conversion table.
- 6 Enter the RGB or CMYK color number.
- 7 Enter an Increment value from 1–255.

Note: The closer the value is to 1, the narrower the color sample range will appear.

- 8 Click **Print** to print the detailed Color Samples set.

Contacting Customer Support

When you call Customer Support, describe the problem you are experiencing, the message on the display, and the troubleshooting steps you have already taken to find a solution.

You need to know your printer model type and serial number. For more information, see the label on the inside top front cover of the printer. The serial number is also listed on the menu settings page.

In the U.S. or Canada, call 1-800-539-6275. For other countries or regions, visit the Lexmark Web site at <http://support.lexmark.com>.

Notices

Product information

Product name:

Lexmark C734n, C734dn, C734dtn, C734dw, C736n, C736dn, C736dtn

Machine type:

5026

Model(s):

210, 230, 280, 410, 430, 480

Edition notice

March 2012

The following paragraph does not apply to any country where such provisions are inconsistent with local law:

LEXMARK INTERNATIONAL, INC., PROVIDES THIS PUBLICATION "AS IS" WITHOUT WARRANTY OF ANY KIND, EITHER EXPRESS OR IMPLIED, INCLUDING, BUT NOT LIMITED TO, THE IMPLIED WARRANTIES OF MERCHANTABILITY OR FITNESS FOR A PARTICULAR PURPOSE. Some states do not allow disclaimer of express or implied warranties in certain transactions; therefore, this statement may not apply to you.

This publication could include technical inaccuracies or typographical errors. Changes are periodically made to the information herein; these changes will be incorporated in later editions. Improvements or changes in the products or the programs described may be made at any time.

References in this publication to products, programs, or services do not imply that the manufacturer intends to make these available in all countries in which it operates. Any reference to a product, program, or service is not intended to state or imply that only that product, program, or service may be used. Any functionally equivalent product, program, or service that does not infringe any existing intellectual property right may be used instead. Evaluation and verification of operation in conjunction with other products, programs, or services, except those expressly designated by the manufacturer, are the user's responsibility.

For Lexmark technical support, visit <http://support.lexmark.com>.

For information on supplies and downloads, visit www.lexmark.com.

If you don't have access to the Internet, you can contact Lexmark by mail:

Lexmark International, Inc.
Bldg 004-2/CSC
740 New Circle Road NW
Lexington, KY 40550
USA

© 2010 Lexmark International, Inc.

All rights reserved.

UNITED STATES GOVERNMENT RIGHTS

This software and any accompanying documentation provided under this agreement are commercial computer software and documentation developed exclusively at private expense.

Trademarks

Lexmark, Lexmark with diamond design, MarkNet, and MarkVision are trademarks of Lexmark International, Inc., registered in the United States and/or other countries.

MarkTrack and PrintCryption are trademarks of Lexmark International, Inc.

Mac and the Mac logo are trademarks of Apple Inc., registered in the U.S. and other countries.

PCL® is a registered trademark of the Hewlett-Packard Company. PCL is Hewlett-Packard Company's designation of a set of printer commands (language) and functions included in its printer products. This printer is intended to be compatible with the PCL language. This means the printer recognizes PCL commands used in various application programs, and that the printer emulates the functions corresponding to the commands.

All other trademarks are the property of their respective owners.

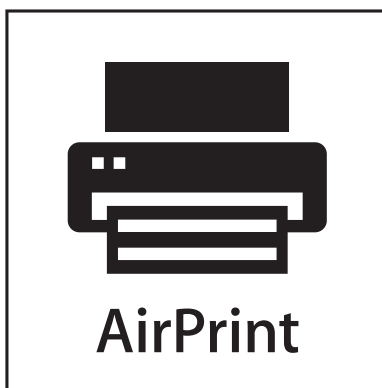

AirPrint and the AirPrint logo are trademarks of Apple, Inc.

Federal Communications Commission (FCC) compliance information statement

This product has been tested and found to comply with the limits for a Class B digital device, pursuant to Part 15 of the FCC Rules. Operation is subject to the following two conditions: (1) this device may not cause harmful interference, and (2) this device must accept any interference received, including interference that may cause undesired operation.

The FCC Class B limits are designed to provide reasonable protection against harmful interference when the equipment is operated in a residential installation. This equipment generates, uses, and can radiate radio frequency energy and, if not installed and used in accordance with the instructions, may cause harmful interference to radio communications. However, there is no guarantee that interference will not occur in a particular installation. If this equipment does cause harmful interference to radio or television reception, which can be determined by turning the equipment off and on, the user is encouraged to try to correct the interference by one or more of the following measures:

- Reorient or relocate the receiving antenna.
- Increase the separation between the equipment and receiver.
- Connect the equipment into an outlet on a circuit different from that to which the receiver is connected.
- Consult your point of purchase or service representative for additional suggestions.

The manufacturer is not responsible for radio or television interference caused by using other than recommended cables or by unauthorized changes or modifications to this equipment. Unauthorized changes or modifications could void the user's authority to operate this equipment.

Note: To assure compliance with FCC regulations on electromagnetic interference for a Class B computing device, use a properly shielded and grounded cable such as Lexmark part number 1021231 for parallel attach or 1021294 for USB attach. Use of a substitute cable not properly shielded and grounded may result in a violation of FCC regulations.

Any questions regarding this compliance information statement should be directed to:

Director of Lexmark Technology & Services
 Lexmark International, Inc.
 740 West New Circle Road
 Lexington, KY 40550
 (859) 232-3000

Modular component notice

Wireless-equipped models contain the following modular component(s):
 Lexmark regulatory type/model LEX-M04-001; FCC ID:IYLLEXM04001; IC:2376A-M04001

Noise emission levels

The following measurements were made in accordance with ISO 7779 and reported in conformance with ISO 9296.

Note: Some modes may not apply to your product.

1-meter average sound pressure, dBA	
Printing	55
Ready	33

Values are subject to change. See www.lexmark.com for current values.

Waste from Electrical and Electronic Equipment (WEEE) directive



The WEEE logo signifies specific recycling programs and procedures for electronic products in countries of the European Union. We encourage the recycling of our products. If you have further questions about recycling options, visit the Lexmark Web site at www.lexmark.com for your local sales office phone number.

Static sensitivity notice



This symbol identifies static-sensitive parts. Do not touch in the areas near these symbols without first touching the metal frame of the printer.

ENERGY STAR

Any Lexmark product bearing the ENERGY STAR emblem on the product or on a start-up screen is certified to comply with Environmental Protection Agency (EPA) ENERGY STAR requirements as configured when shipped by Lexmark.



Temperature information

Ambient temperature	15.6 to 32.2° C (60 to 90° F)
Shipping and storage temperature	-40° to 40° C (104° F)

Laser notice

The printer is certified in the U.S. to conform to the requirements of DHHS 21 CFR Subchapter J for Class I (1) laser products, and elsewhere is certified as a Class I laser product conforming to the requirements of IEC 60825-1.

Class I laser products are not considered to be hazardous. The printer contains internally a Class IIIb (3b) laser that is nominally a 7 milliwatt gallium arsenide laser operating in the wavelength of 655-675 nanometers. The laser system and printer are designed so there is never any human access to laser radiation above a Class I level during normal operation, user maintenance, or prescribed service condition.

Laser advisory label

A laser notice label may be affixed to this printer as shown:

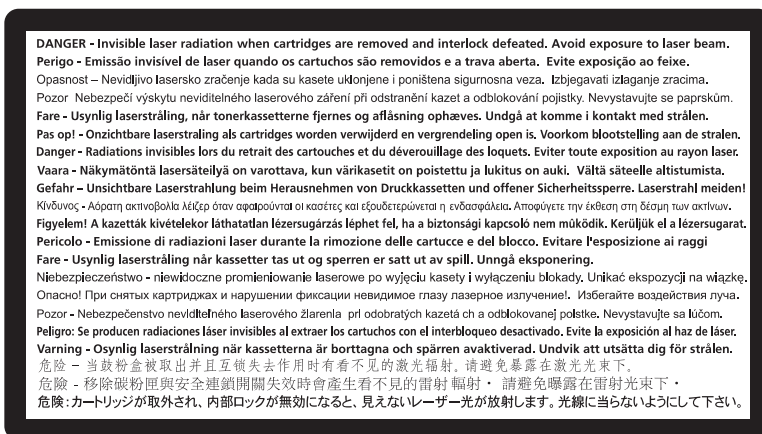

Power consumption

Product power consumption

The following table documents the power consumption characteristics of the product.

Note: Some modes may not apply to your product.

Mode	Description	Power consumption (Watts)
Printing	The product is generating hard-copy output from electronic inputs.	490, 530
Copying	The product is generating hard-copy output from hard-copy original documents.	N/A
Scanning	The product is scanning hard-copy documents.	N/A
Ready	The product is waiting for a print job.	45
Power Saver	The product is in energy-saving mode.	16
Off	The product is plugged into a wall outlet, but the power switch is turned off.	0

The power consumption levels listed in the previous table represent time-averaged measurements. Instantaneous power draws may be substantially higher than the average.

Values are subject to change. See www.lexmark.com for current values.

Power Saver

This product is designed with an energy-saving mode called Power Saver. The Power Saver Mode is equivalent to the Sleep Mode. The Power Saver Mode saves energy by lowering power consumption during extended periods of inactivity. The Power Saver Mode is automatically engaged after this product is not used for a specified period of time, called the Power Saver Timeout.

Factory default Power Saver Timeout for this product (in minutes):	30
--	----

By using the configuration menus, the Power Saver Timeout can be modified between 1 minute and 240 minutes. Setting the Power Saver Timeout to a low value reduces energy consumption, but may increase the response time of the product. Setting the Power Saver Timeout to a high value maintains a fast response, but uses more energy.

Off mode

If this product has an off mode which still consumes a small amount of power, then to completely stop product power consumption, disconnect the power supply cord from the wall outlet.

Total energy usage

It is sometimes helpful to calculate the total product energy usage. Since power consumption claims are provided in power units of Watts, the power consumption should be multiplied by the time the product spends in each mode in order to calculate energy usage. The total product energy usage is the sum of each mode's energy usage.

Industry Canada compliance statement

This Class B digital apparatus meets all requirements of the Canadian Interference-Causing Equipment Standard ICES-003.

Avis de conformité aux normes de l'industrie du Canada

Cet appareil numérique de classe B est conforme aux exigences de la norme canadienne relative aux équipements pouvant causer des interférences NMB-003.

European Community (EC) directives conformity

This product is in conformity with the protection requirements of EC Council directives 2004/108/EC and 2006/95/EC on the approximation and harmonization of the laws of the Member States relating to electromagnetic compatibility and safety of electrical equipment designed for use within certain voltage limits.

The manufacturer of this product is: Lexmark International, Inc., 740 West New Circle Road, Lexington, KY, 40550 USA. The authorized representative is: Lexmark International Technology Hungária Kft., 8 Lechner Ödön fasor, Millennium Tower III, 1095 Budapest HUNGARY, A declaration of conformity to the requirements of the Directives is available upon request from the Authorized Representative.

This product satisfies the Class B limits of EN 55022 and safety requirements of EN 60950.

Regulatory notices for wireless products

This section contains the following regulatory information pertaining to wireless products that contain transmitters, for example, but not limited to, wireless network cards or proximity card readers.

Exposure to radio frequency radiation

The radiated output power of this device is far below the radio frequency exposure limits of the FCC and other regulatory agencies. A minimum separation of 20 cm (8 inches) must be maintained between the antenna and any persons for this device to satisfy the RF exposure requirements of the FCC and other regulatory agencies.

Industry Canada (Canada)

This device complies with Industry Canada specification RSS-210. Operation is subject to the following two conditions: (1) this device may not cause interference, and (2) this device must accept any interference, including interference that may cause undesired operation of the device.

This device has been designed to operate only with the antenna provided. Use of any other antenna is strictly prohibited per regulations of Industry Canada.

To prevent radio interference to the licensed service, this device is intended to be operated indoors and away from windows to provide maximum shielding. Equipment (or its transmit antenna) that is installed outdoors is subject to licensing.

The installer of this radio equipment must ensure that the antenna is located or pointed such that it does not emit RF fields in excess of Health Canada limits for the general population; consult Safety Code 6, obtainable from Health Canada's Web site www.hc-sc.gc.ca/rpb.

The term "IC:" before the certification/registration number only signifies that the Industry Canada technical specifications were met.

Industry Canada (Canada)

Cet appareil est conforme à la norme RSS-210 d'Industry Canada. Son fonctionnement est soumis aux deux conditions suivantes :

(1) cet appareil ne doit pas provoquer d'interférences et (2) il doit accepter toute interférence reçue, y compris celles risquant d'altérer son fonctionnement.

Cet appareil a été conçu pour fonctionner uniquement avec l'antenne fournie. L'utilisation de toute autre antenne est strictement interdite par la réglementation d'Industry Canada.

En application des réglementations d'Industry Canada, l'utilisation d'une antenne de gain supérieur est strictement interdite.

Pour empêcher toute interférence radio au service faisant l'objet d'une licence, cet appareil doit être utilisé à l'intérieur et loin des fenêtres afin de garantir une protection optimale.

Si le matériel (ou son antenne d'émission) est installé à l'extérieur, il doit faire l'objet d'une licence.

L'installateur de cet équipement radio doit veiller à ce que l'antenne soit implantée et dirigée de manière à n'émettre aucun champ HF dépassant les limites fixées pour l'ensemble de la population par Santé Canada. Reportez-vous au Code de sécurité 6 que vous pouvez consulter sur le site Web de Santé Canada www.hc-sc.gc.ca/rpb.

Le terme « IC » précédant le numéro de d'accréditation/inscription signifie simplement que le produit est conforme aux spécifications techniques d'Industry Canada.

Notice to users in the European Union

Products bearing the CE mark are in conformity with the protection requirements of EC Council directives 2004/108/EC, 2006/95/EC, and 1999/5/EC on the approximation and harmonization of the laws of the Member States relating to electromagnetic compatibility, safety of electrical equipment designed for use within certain voltage limits and on radio equipment and telecommunications terminal equipment.

Compliance is indicated by the CE marking.



The manufacturer of this product is: Lexmark International, Inc., 740 West New Circle Road, Lexington, KY, 40550 USA. The authorized representative is: Lexmark International Technology Hungária Kft., 8 Lechner Ödön fasor, Millennium Tower III, 1095 Budapest HUNGARY, A declaration of conformity to the requirements of the Directives is available upon request from the Authorized Representative.

This product satisfies the Class B limits of EN 55022 and safety requirements of EN 60950.

Products equipped with 2.4GHz Wireless LAN option are in conformity with the protection requirements of EC Council directives 2004/108/EC, 2006/95/EC, and 1999/5/EC on the approximation and harmonization of the laws of the Member States relating to electromagnetic compatibility, safety of electrical equipment designed for use within certain voltage limits and on radio equipment and telecommunications terminal equipment.

Compliance is indicated by the CE marking.



Operation is allowed in all EU and EFTA countries, but is restricted to indoor use only.

The manufacturer of this product is: Lexmark International, Inc., 740 West New Circle Road, Lexington, KY, 40550 USA. The authorized representative is: Lexmark International Technology Hungária Kft., 8 Lechner Ödön fasor, Millennium Tower III, 1095 Budapest HUNGARY, A declaration of conformity to the requirements of the Directives is available upon request from the Authorized Representative.

Česky	Společnost Lexmark International, Inc. tímto prohlašuje, že výrobek tento výrobek je ve shodě se základními požadavky a dalšími příslušnými ustanoveními směrnice 1999/5/ES.
Dansk	Lexmark International, Inc. erklærer herved, at dette produkt overholder de væsentlige krav og øvrige relevante krav i direktiv 1999/5/EF.
Deutsch	Hiermit erklärt Lexmark International, Inc., dass sich das Gerät dieses Gerät in Übereinstimmung mit den grundlegenden Anforderungen und den übrigen einschlägigen Bestimmungen der Richtlinie 1999/5/EG befindet.
Ελληνική	ΜΕ ΤΗΝ ΠΑΡΟΥΣΑ Η LEXMARK INTERNATIONAL, INC. ΔΗΛΩΝΕΙ ΟΤΙ ΑΥΤΟ ΤΟ ΠΡΟΪΟΝ ΣΥΜΜΟΡΦΩΝΕΤΑΙ ΠΡΟΣ ΤΙΣ ΟΥΣΙΩΔΕΙΣ ΑΠΑΙΤΗΣΕΙΣ ΚΑΙ ΤΙΣ ΛΟΙΠΕΣ ΣΧΕΤΙΚΕΣ ΔΙΑΤΑΞΕΙΣ ΤΗΣ ΟΔΗΓΙΑΣ 1999/5/ΕΚ.
English	Hereby, Lexmark International, Inc., declares that this type of equipment is in compliance with the essential requirements and other relevant provisions of Directive 1999/5/EC.
Español	Por medio de la presente, Lexmark International, Inc. declara que este producto cumple con los requisitos esenciales y cualesquiera otras disposiciones aplicables o exigibles de la Directiva 1999/5/CE.

Eesti	Käesolevaga kinnitab Lexmark International, Inc., et seade see toode vastab direktiivi 1999/5/EÜ põhinõuetele ja nimetatud direktiivist tulenevatele muudele asjakohastele sätetele.
Suomi	Lexmark International, Inc. vakuuttaa täten, että tämä tuote on direktiivin 1999/5/EY oleellisten vaatimusten ja muiden sitä koskevien direktiivin ehtojen mukainen.
Français	Par la présente, Lexmark International, Inc. déclare que l'appareil ce produit est conforme aux exigences fondamentales et autres dispositions pertinentes de la directive 1999/5/CE.
Magyar	Alulírott, Lexmark International, Inc. nyilatkozom, hogy a termék megfelel a vonatkozó alapvető követelményeknek és az 1999/5/EC irányelv egyéb előírásainak.
Íslenska	Hér með lýsir Lexmark International, Inc. yfir því að þessi vara er í samræmi við grunnkröfur og aðrar kröfur, sem gerðar eru í tilskipun 1999/5/EC.
Italiano	Con la presente Lexmark International, Inc. dichiara che questo prodotto è conforme ai requisiti essenziali ed alle altre disposizioni pertinenti stabilite dalla direttiva 1999/5/CE.
Latviski	Ar šo Lexmark International, Inc. deklarē, ka šis izstrādājums atbilst Direktīvas 1999/5/EK būtiskajām prasībām un citiem ar to saistītajiem noteikumiem.
Lietuvių	Šiuo Lexmark International, Inc. deklaruoja, kad šis produktas atitinka esminius reikalavimus ir kitas 1999/5/EB direktyvos nuostatas.
Malti	Bil-preżenti, Lexmark International, Inc., jiddikjara li dan il-prodott huwa konformi mal-ftiġijiet essenzjali u ma dispożizzjonijiet oħrajn relevanti li jinsabu fid-Direttiva 1999/5/KE.
Nederlands	Hierbij verklaart Lexmark International, Inc. dat het toestel dit product in overeenstemming is met de essentiële eisen en de andere relevante bepalingen van richtlijn 1999/5/EG.
Norsk	Lexmark International, Inc. erklærer herved at dette produktet er i samsvar med de grunnleggende krav og øvrige relevante krav i direktiv 1999/5/EF.
Polski	Niniejszym Lexmark International, Inc. oświadcza, że niniejszy produkt jest zgodny z zasadniczymi wymogami oraz pozostałymi stosownymi postanowieniami Dyrektywy 1999/5/EC.
Português	A Lexmark International Inc. declara que este produto está conforme com os requisitos essenciais e outras disposições da Diretiva 1999/5/CE.
Slovensky	Lexmark International, Inc. týmto vyhlasuje, že tento produkt spĺňa základné požiadavky a všetky príslušné ustanovenia smernice 1999/5/ES.
Slovensko	Lexmark International, Inc. izjavlja, da je ta izdelek v skladu z bistvenimi zahtevami in ostalimi relevantnimi določili direktive 1999/5/ES.
Svenska	Härmed intygar Lexmark International, Inc. att denna produkt står i överensstämmelse med de väsentliga egenskapskrav och övriga relevanta bestämmelser som framgår av direktiv 1999/5/EG.

Statement of Limited Warranty

Lexmark C734n, C734dn, C734dtn, C734dw, C736n, C736dn, C736dtn

Lexmark International, Inc., Lexington, KY

This limited warranty applies to the United States and Canada. For customers outside the U.S., refer to the country-specific warranty information that came with your product.

This limited warranty applies to this product only if it was originally purchased for your use, and not for resale, from Lexmark or a Lexmark Remarketer, referred to in this statement as "Remarketer."

Limited warranty

Lexmark warrants that this product:

- Is manufactured from new parts, or new and serviceable used parts, which perform like new parts
- Is, during normal use, free from defects in material and workmanship

If this product does not function as warranted during the warranty period, contact a Remarketer or Lexmark for repair or replacement (at Lexmark's option).

If this product is a feature or option, this statement applies only when that feature or option is used with the product for which it was intended. To obtain warranty service, you may be required to present the feature or option with the product.

If you transfer this product to another user, warranty service under the terms of this statement is available to that user for the remainder of the warranty period. You should transfer proof of original purchase and this statement to that user.

Limited warranty service

The warranty period starts on the date of original purchase as shown on the purchase receipt and ends 12 months later provided that the warranty period for any supplies and for any maintenance items included with the printer shall end earlier if it, or its original contents, are substantially used up, depleted, or consumed.

To obtain warranty service you may be required to present proof of original purchase. You may be required to deliver your product to the Remarketer or Lexmark, or ship it prepaid and suitably packaged to a Lexmark designated location. You are responsible for loss of, or damage to, a product in transit to the Remarketer or the Lexmark designated location.

When warranty service involves the exchange of a product or part, the item replaced becomes the property of the Remarketer or Lexmark. The replacement may be a new or repaired item.

The replacement item assumes the remaining warranty period of the original product.

Replacement is not available to you if the product you present for exchange is defaced, altered, in need of a repair not included in warranty service, damaged beyond repair, or if the product is not free of all legal obligations, restrictions, liens, and encumbrances.

Before you present this product for warranty service, remove all print cartridges, programs, data, and removable storage media (unless directed otherwise by Lexmark).

For further explanation of your warranty alternatives and the nearest Lexmark authorized servicer in your area contact Lexmark on the World Wide Web at <http://support.lexmark.com>.

Remote technical support is provided for this product throughout its warranty period. For products no longer covered by a Lexmark warranty, technical support may not be available or only be available for a fee.

Extent of limited warranty

Lexmark does not warrant uninterrupted or error-free operation of any product or the durability or longevity of prints produced by any product.

Warranty service does not include repair of failures caused by:

- Modification or unauthorized attachments
- Accidents, misuse, abuse or use inconsistent with Lexmark user's guides, manuals, instructions or guidance
- Unsuitable physical or operating environment

- Maintenance by anyone other than Lexmark or a Lexmark authorized servicer
- Operation of a product beyond the limit of its duty cycle
- Use of printing media outside of Lexmark specifications
- Refurbishment, repair, refilling or remanufacture by a third party of products, supplies or parts
- Products, supplies, parts, materials (such as toners and inks), software, or interfaces not furnished by Lexmark

TO THE EXTENT PERMITTED BY APPLICABLE LAW, NEITHER LEXMARK NOR ITS THIRD PARTY SUPPLIERS OR REMARKETERS MAKE ANY OTHER WARRANTY OR CONDITION OF ANY KIND, WHETHER EXPRESS OR IMPLIED, WITH RESPECT TO THIS PRODUCT, AND SPECIFICALLY DISCLAIM THE IMPLIED WARRANTIES OR CONDITIONS OF MERCHANTABILITY, FITNESS FOR A PARTICULAR PURPOSE, AND SATISFACTORY QUALITY. ANY WARRANTIES THAT MAY NOT BE DISCLAIMED UNDER APPLICABLE LAW ARE LIMITED IN DURATION TO THE WARRANTY PERIOD. NO WARRANTIES, EXPRESS OR IMPLIED, WILL APPLY AFTER THIS PERIOD. ALL INFORMATION, SPECIFICATIONS, PRICES, AND SERVICES ARE SUBJECT TO CHANGE AT ANY TIME WITHOUT NOTICE.

Limitation of liability

Your sole remedy under this limited warranty is set forth in this document. For any claim concerning performance or nonperformance of Lexmark or a Remarketer for this product under this limited warranty, you may recover actual damages up to the limit set forth in the following paragraph.

Lexmark's liability for actual damages from any cause whatsoever will be limited to the amount you paid for the product that caused the damages. This limitation of liability will not apply to claims by you for bodily injury or damage to real property or tangible personal property for which Lexmark is legally liable. **IN NO EVENT WILL LEXMARK BE LIABLE FOR ANY LOST PROFITS, LOST SAVINGS, INCIDENTAL DAMAGE, OR OTHER ECONOMIC OR CONSEQUENTIAL DAMAGES.** This is true even if you advise Lexmark or a Remarketer of the possibility of such damages. Lexmark is not liable for any claim by you based on a third party claim.

This limitation of remedies also applies to claims against any Suppliers and Remarketers of Lexmark. Lexmark's and its Suppliers' and Remarketers' limitations of remedies are not cumulative. Such Suppliers and Remarketers are intended beneficiaries of this limitation.

Additional rights

Some states do not allow limitations on how long an implied warranty lasts, or do not allow the exclusion or limitation of incidental or consequential damages, so the limitations or exclusions contained above may not apply to you.

This limited warranty gives you specific legal rights. You may also have other rights that vary from state to state.

LEXMARK SOFTWARE LIMITED WARRANTY AND LICENSE AGREEMENT

PLEASE READ CAREFULLY BEFORE USING THIS PRODUCT: BY USING THIS PRODUCT, YOU AGREE TO BE BOUND BY ALL THE TERMS AND CONDITIONS OF THIS SOFTWARE LIMITED WARRANTY AND LICENSE AGREEMENT. IF YOU DO NOT AGREE WITH THE TERMS OF THIS SOFTWARE LIMITED WARRANTY AND LICENSE AGREEMENT, PROMPTLY RETURN THE PRODUCT UNUSED AND REQUEST A REFUND OF THE AMOUNT YOU PAID. IF YOU ARE INSTALLING THIS PRODUCT FOR USE BY OTHER PARTIES, YOU AGREE TO INFORM THE USERS THAT USE OF THE PRODUCT INDICATES ACCEPTANCE OF THESE TERMS.

LEXMARK SOFTWARE LICENSE AGREEMENT

This License Agreement ("Software License Agreement") is a legal agreement between you (either an individual or a single entity) and Lexmark International, Inc. ("Lexmark") that, to the extent your Lexmark product or Software Program

is not otherwise subject to a written software license agreement between you and Lexmark or its suppliers, governs your use of any Software Program installed on or provided by Lexmark for use in connection with your Lexmark product. The term "Software Program" includes machine-readable instructions, audio/visual content (such as images and recordings), and associated media, printed materials and electronic documentation, whether incorporated into, distributed with or for use with your Lexmark product.

- 1 STATEMENT OF SOFTWARE LIMITED WARRANTY.** Lexmark warrants that the media (e.g., diskette or compact disk) on which the Software Program (if any) is furnished is free from defects in materials and workmanship under normal use during the warranty period. The warranty period is ninety (90) days and commences on the date the Software Program is delivered to the original end-user. This limited warranty applies only to Software Program media purchased new from Lexmark or an Authorized Lexmark Reseller or Distributor. Lexmark will replace the Software Program should it be determined that the media does not conform to this limited warranty.
- 2 DISCLAIMER AND LIMITATION OF WARRANTIES.** EXCEPT AS PROVIDED IN THIS SOFTWARE LICENSE AGREEMENT AND TO THE MAXIMUM EXTENT PERMITTED BY APPLICABLE LAW, LEXMARK AND ITS SUPPLIERS PROVIDE THE SOFTWARE PROGRAM "AS IS" AND HEREBY DISCLAIM ALL OTHER WARRANTIES AND CONDITIONS, EITHER EXPRESS OR IMPLIED, INCLUDING, BUT NOT LIMITED TO, TITLE, NON-INFRINGEMENT, MERCHANTABILITY AND FITNESS FOR A PARTICULAR PURPOSE, AND ABSENCE OF VIRUSES, ALL WITH REGARD TO THE SOFTWARE PROGRAM. TO THE EXTENT LEXMARK CANNOT BY LAW DISCLAIM ANY COMPONENT OF THE IMPLIED WARRANTIES OF MERCHANTABILITY OR FITNESS FOR A PARTICULAR PURPOSE, LEXMARK LIMITS THE DURATION OF SUCH WARRANTIES TO THE 90-DAY TERM OF THE EXPRESS SOFTWARE LIMITED WARRANTY.

This Agreement is to be read in conjunction with certain statutory provisions, as that may be in force from time to time, that imply warranties or conditions or impose obligations on Lexmark that cannot be excluded or modified. If any such provisions apply, then to the extent Lexmark is able, Lexmark hereby limits its liability for breach of those provisions to one of the following: providing you a replacement copy of the Software Program or reimbursement of the price paid for the Software Program.

The Software Program may include internet links to other software applications and/or internet web pages hosted and operated by third parties unaffiliated with Lexmark. You acknowledge and agree that Lexmark is not responsible in any way for the hosting, performance, operation, maintenance, or content of, such software applications and/or internet web pages.

- 3 LIMITATION OF REMEDY.** TO THE MAXIMUM EXTENT PERMITTED BY APPLICABLE LAW, ANY AND ALL LIABILITY OF LEXMARK UNDER THIS SOFTWARE LICENSE AGREEMENT IS EXPRESSLY LIMITED TO THE GREATER OF THE PRICE PAID FOR THE SOFTWARE PROGRAM AND FIVE U.S. DOLLARS (OR THE EQUIVALENT IN LOCAL CURRENCY). YOUR SOLE REMEDY AGAINST LEXMARK IN ANY DISPUTE UNDER THIS SOFTWARE LICENSE AGREEMENT SHALL BE TO SEEK TO RECOVER ONE OF THESE AMOUNTS, UPON PAYMENT OF WHICH LEXMARK SHALL BE RELEASED AND DISCHARGED OF ALL FURTHER OBLIGATIONS AND LIABILITY TO YOU.

IN NO EVENT WILL LEXMARK, ITS SUPPLIERS, SUBSIDIARIES, OR RESELLERS BE LIABLE FOR ANY SPECIAL, INCIDENTAL, INDIRECT, EXEMPLARY, PUNITIVE, OR CONSEQUENTIAL DAMAGES (INCLUDING BUT NOT LIMITED TO LOST PROFITS OR REVENUES, LOST SAVINGS, INTERRUPTION OF USE OR ANY LOSS OF, INACCURACY IN, OR DAMAGE TO, DATA OR RECORDS, FOR CLAIMS OF THIRD PARTIES, OR DAMAGE TO REAL OR TANGIBLE PROPERTY, FOR LOSS OF PRIVACY ARISING OUT OR IN ANY WAY RELATED TO THE USE OF OR INABILITY TO USE THE SOFTWARE PROGRAM, OR OTHERWISE IN CONNECTION WITH ANY PROVISION OF THIS SOFTWARE LICENSE AGREEMENT), REGARDLESS OF THE NATURE OF THE CLAIM, INCLUDING BUT NOT LIMITED TO BREACH OF WARRANTY OR CONTRACT, TORT (INCLUDING NEGLIGENCE OR STRICT LIABILITY), AND EVEN IF LEXMARK, OR ITS SUPPLIERS, AFFILIATES, OR REMARKETERS HAVE BEEN ADVISED OF THE POSSIBILITY OF SUCH DAMAGES, OR FOR ANY CLAIM BY YOU BASED ON A THIRD-PARTY CLAIM, EXCEPT TO THE EXTENT THIS EXCLUSION OF DAMAGES IS DETERMINED LEGALLY INVALID. THE FOREGOING LIMITATIONS APPLY EVEN IF THE ABOVE-STATED REMEDIES FAIL OF THEIR ESSENTIAL PURPOSE.

- 4 U.S.A. STATE LAWS.** This Software Limited Warranty gives you specific legal rights. You may also have other rights that vary from state to state. Some states do not allow limitations on how long an implied warranty lasts or the exclusion of limitation of incidental or consequential damages, so the above limitations may not apply to you.

- 5 LICENSE GRANT.** Lexmark grants you the following rights provided you comply with all terms and conditions of this License Agreement:
- a Use.** You may Use one (1) copy of the Software Program. The term “Use” means storing, loading, installing, executing, or displaying the Software Program. If Lexmark has licensed the Software Program to you for concurrent use, you must limit the number of authorized users to the number specified in your agreement with Lexmark. You may not separate the components of the Software Program for use on more than one computer. You agree that you will not Use the Software Program, in whole or in part, in any manner that has the effect of overriding, modifying, eliminating, obscuring, altering or de-emphasizing the visual appearance of any trademark, trade name, trade dress or intellectual property notice that appears on any computer display screens normally generated by, or as a result of, the Software Program.
 - b Copying.** You may make one (1) copy of the Software Program solely for purposes of backup, archiving, or installation, provided the copy contains all of the original Software Program’s proprietary notices. You may not copy the Software Program to any public or distributed network.
 - c Reservation of Rights.** The Software Program, including all fonts, is copyrighted and owned by Lexmark International, Inc. and/or its suppliers. Lexmark reserves all rights not expressly granted to you in this License Agreement.
 - d Freeware.** Notwithstanding the terms and conditions of this License Agreement, all or any portion of the Software Program that constitutes software provided under public license by third parties (“Freeware”) is licensed to you subject to the terms and conditions of the software license agreement accompanying such Freeware, whether in the form of a discrete agreement, shrink-wrap license, or electronic license terms at the time of download. Use of the Freeware by you shall be governed entirely by the terms and conditions of such license.
- 6 TRANSFER.** You may transfer the Software Program to another end-user. Any transfer must include all software components, media, printed materials, and this License Agreement and you may not retain copies of the Software Program or components thereof. The transfer may not be an indirect transfer, such as a consignment. Prior to the transfer, the end-user receiving the transferred Software Program must agree to all these License Agreement terms. Upon transfer of the Software Program, your license is automatically terminated. You may not rent, sublicense, or assign the Software Program except to the extent provided in this License Agreement, and any attempt to do so shall be void.
- 7 UPGRADES.** To Use a Software Program identified as an upgrade, you must first be licensed to the original Software Program identified by Lexmark as eligible for the upgrade. After upgrading, you may no longer use the original Software Program that formed the basis for your upgrade eligibility.
- 8 LIMITATION ON REVERSE ENGINEERING.** You may not alter, decrypt, reverse engineer, reverse assemble, reverse compile or otherwise translate the Software Program, except as and to the extent expressly permitted to do so by applicable law for the purposes of inter-operability, error correction, and security testing. If you have such statutory rights, you will notify Lexmark in writing of any intended reverse engineering, reverse assembly, or reverse compilation. You may not decrypt the Software Program unless necessary for the legitimate Use of the Software Program.
- 9 ADDITIONAL SOFTWARE.** This License Agreement applies to updates or supplements to the original Software Program provided by Lexmark unless Lexmark provides other terms along with the update or supplement.
- 10 TERM.** This License Agreement is effective unless terminated or rejected. You may reject or terminate this license at any time by destroying all copies of the Software Program, together with all modifications, documentation, and merged portions in any form, or as otherwise described herein. Lexmark may terminate your license upon notice if you fail to comply with any of the terms of this License Agreement. Upon such termination, you agree to destroy all copies of the Software Program together with all modifications, documentation, and merged portions in any form.
- 11 TAXES.** You agree that you are responsible for payment of any taxes including, without limitation, any goods and services and personal property taxes, resulting from this Agreement or your Use of the Software Program.

- 12 LIMITATION ON ACTIONS.** No action, regardless of form, arising out of this Agreement may be brought by either party more than two years after the cause of action has arisen, except as provided under applicable law.
- 13 APPLICABLE LAW.** This Agreement is governed by the laws of the Commonwealth of Kentucky, United States of America. No choice of law rules in any jurisdiction shall apply. The UN Convention on Contracts for the International Sale of Goods shall not apply.
- 14 UNITED STATES GOVERNMENT RESTRICTED RIGHTS.** The Software Program has been developed entirely at private expense. Rights of the United States Government to use the Software Program is as set forth in this Agreement and as restricted in DFARS 252.227-7014 and in similar FAR provisions (or any equivalent agency regulation or contract clause).
- 15 CONSENT TO USE OF DATA.** You agree that Lexmark, its affiliates, and agents may collect and use information you provide in relation to support services performed with respect to the Software Program and requested by you. Lexmark agrees not to use this information in a form that personally identifies you except to the extent necessary to provide such services.
- 16 EXPORT RESTRICTIONS.** You may not (a) acquire, ship, transfer, or reexport, directly or indirectly, the Software Program or any direct product therefrom, in violation of any applicable export laws or (b) permit the Software Program to be used for any purpose prohibited by such export laws, including, without limitation, nuclear, chemical, or biological weapons proliferation.
- 17 AGREEMENT TO CONTRACT ELECTRONICALLY.** You and Lexmark agree to form this License Agreement electronically. This means that when you click the “Agree” or “Yes” button on this page or use this product, you acknowledge your agreement to these License Agreement terms and conditions and that you are doing so with the intent to “sign” a contract with Lexmark.
- 18 CAPACITY AND AUTHORITY TO CONTRACT.** You represent that you are of the legal age of majority in the place you sign this License Agreement and, if applicable, you are duly authorized by your employer or principal to enter into this contract.
- 19 ENTIRE AGREEMENT.** This License Agreement (including any addendum or amendment to this License Agreement that is included with the Software Program) is the entire agreement between you and Lexmark relating to the Software Program. Except as otherwise provided for herein, these terms and conditions supersede all prior or contemporaneous oral or written communications, proposals, and representations with respect to the Software Program or any other subject matter covered by this License Agreement (except to the extent such extraneous terms do not conflict with the terms of this License Agreement, any other written agreement signed by you and Lexmark relating to your Use of the Software Program). To the extent any Lexmark policies or programs for support services conflict with the terms of this License Agreement, the terms of this License Agreement shall control.

ADOBE SYSTEMS INCORPORATED NOTICE

Contains Flash®, Flash® Lite™ and/or Reader® technology by Adobe Systems Incorporated

This Product contains Adobe® Flash® player software under license from Adobe Systems Incorporated, Copyright © 1995-2007 Adobe Macromedia Software LLC. All rights reserved. Adobe, Reader and Flash are trademarks of Adobe Systems Incorporated.

Index

Numerics

2,000-sheet tray
installing 30

31.yy Missing or defective <color> cartridge 162

32.yy <Color> cartridge part number unsupported by device 162

34 Short paper 162

35 Insufficient memory to support Resource Save feature 162

37 Insufficient memory to collate job 163

37 Insufficient memory, some held jobs deleted 163

37 Insufficient memory, some held jobs will not be restored 163

38 Memory full 163

39 Complex page, some data may not have printed 163

51 Defective flash detected 163

52 Not enough free space in flash memory for resources 164

54 Network <x> software error 164

54 Standard network software error 164

55 Unsupported option in slot 164

550-sheet specialty media drawer installing 30

550-sheet tray installing 30

56 Parallel port <x> disabled 164

56 Serial port <x> disabled 165

56 Standard USB port disabled 165

57 Configuration change, held jobs were not restored 165

58 Too many disks installed 165

58 Too many flash options installed 165

58 Too many trays attached 166

59 Incompatible tray <x> 166

61 Remove defective hard disk 166

62 Disk full 166

63 Unformatted disk 166

80.xx Fuser life warning 167

80.xx Fuser missing 167

80.xx Fuser near life warning 166

80.xx Replace fuser 167

82.yy Replace waste toner box 167

82.yy Waste toner box missing 167

82.yy Waste toner box nearly full 167

83.xx Replace transfer module 168

83.xx Transfer module life warning 167

83.xx Transfer module missing 168

83.xx Transfer module near life warning 167

84.xx <color> photoconductor low 168

84.xx <color> photoconductor missing 168

84.xx <color> photoconductor nearly low 168

84.xx Replace <color> photoconductor 168

88.1x <color> cartridge nearly low 168

88.2x Replace <color> cartridge 169

88.yy <color> cartridge low 168

A

Active NIC menu 89

AppleTalk menu 95

attaching cables 32

B

black-and-white printing 75

brightness, adjusting 50

C

cables
Ethernet 32
USB 32

calling Customer Support 193

canceling a job
from Macintosh 74
from the printer control panel 73
from Windows 74

card stock
tips 69

Change <src> to <custom string> 157

Change <src> to <custom type name> 157

Change <src> to <size> 157

Change <src> to <type> <size> 158

checking an unresponsive printer 169

checking device status
on Embedded Web Server 145

checking virtual display
on Embedded Web Server 145

cleaning
exterior of the printer 130
printhead lenses 130

Close front door 158

Close top access cover 158

Confidential print jobs 69
printing from Macintosh computer 70
printing from Windows 70

Confidential Print menu 104

configuration information
wireless network 36

configurations
printer 10

Configure MP menu 81

configuring
multiple printers 147
port settings 43

conservation settings
brightness, adjusting 50
Eco-Mode 48
Quiet Mode 49

conserving supplies 47

contacting Customer Support 193

custom paper type name
creating 58

Custom Type <x>
changing name 58

Custom Types menu 87

D

Default Source menu 78

directory list
printing 73

Disk Corrupted 158

Disk Wiping menu 105

display 12

display troubleshooting
 display is blank 170
 display shows only diamonds 170
 display, printer control panel
 adjusting brightness 50
 documents, printing
 from Macintosh computer 66
 from Windows 66

E

Eco-Mode setting 48
 Embedded Web Server 145
 administrator settings 145
 checking device status 145
 copying settings to other
 printers 147
 does not open 169
 networking settings 145
 setting up e-mail alerts 146
 Embedded Web Server
 Administrator's Guide 145
 emission
 notices 195, 196, 199, 200, 201
 envelopes
 loading 55
 tips 67
 environmental settings 47
 brightness, adjusting 50
 Eco-Mode 48
 Quiet Mode 49
 Ethernet networking
 Macintosh 41
 Windows 41
 Ethernet port 32
 exterior of the printer
 cleaning 130
 e-mail
 notice of low supply level 146
 notice of paper jam 146
 notice of paper needed 146
 notice that different paper is
 needed 146

F

factory defaults, restoring 146
 FAQ about color printing 190
 FCC notices 195, 200
 fiber optic
 network setup 41
 finding
 information 7

publications 7
 Web site 7
 Finishing menu 114
 firmware card
 installing 18
 flash drive 71
 Flash Drive menu 126
 flash memory card
 installing 18
 troubleshooting 175
 font sample list
 printing 72
 fuser or transfer module
 ordering 133

G

General Settings menu 108
 green settings
 Eco-Mode 48
 Quiet Mode 49

H

hard disk with adapter
 troubleshooting 175
 held jobs 69
 printing from Macintosh
 computer 70
 printing from Windows 70
 Help menu 128
 HTML menu 124

I

Image menu 125
 information, finding 7
 Insert tray <x> 158
 installation
 wireless network 36, 38
 installing
 options in driver 35
 printer software 34
 installing printer software
 adding options 35
 internal print server
 troubleshooting 176
 Internal Solutions Port
 installing 20
 troubleshooting 175
 Internal Solutions Port, network
 changing port settings 43
 IPv6 menu 94

J

jams
 accessing jam areas 148
 avoiding 148
 locations 148
 number 148
 jams, clearing
 200–201 149
 202 150
 203 153
 24x 155
 250 156

L

labels, paper
 tips 68
 letterhead
 guidelines 67
 tips on using 67
 LexLink menu 96
 linking trays 58
 Load <src> with <custom
 string> 159
 Load <src> with <custom type
 name> 158
 Load <src> with <size> 159
 Load <src> with <type> <size> 159
 Load Manual Feeder with <custom
 string> 160
 Load Manual Feeder with <custom
 type name> 159
 Load Manual Feeder with
 <size> 160
 Load Manual Feeder with <type>
 <size> 160
 loading
 envelopes 55
 multipurpose feeder 55
 paper tray 52
 transparencies 55
 lock, security 12

M

Macintosh
 wireless network installation 38
 max speed and max yield
 printing 75
 memory card
 installing 16
 troubleshooting 175

- menu settings
 - loading on multiple printers 147
- menu settings page
 - printing 33
- menus
 - Active NIC 89
 - AppleTalk 95
 - Confidential Print 104
 - Configure MP 81
 - Custom Types 87
 - Default Source 78
 - Disk Wiping 105
 - Finishing 114
 - Flash Drive 126
 - General Settings 108
 - Help 128
 - HTML 124
 - Image 125
 - IPv6 94
 - LexLink 96
 - Miscellaneous 104
 - NetWare 95
 - Network <x> 90
 - Network Card 92
 - Network Reports 91
 - Paper Loading 86
 - Paper Size/Type 78
 - Paper Texture 82
 - Paper Weight 84
 - Parallel <x> menu 98
 - PCL Emul 121
 - PDF 120
 - PictBridge 126
 - PostScript 120
 - Quality 115
 - Reports 88
 - Security Audit Log 106
 - Serial <x> 100
 - Set Date/Time 107
 - Settings 112
 - SMTP Setup menu 102
 - Standard Network 90
 - Standard USB 96
 - Substitute Size 82
 - Supplies 77
 - TCP/IP 92
 - Utilities 119
 - Wireless 94
 - XPS 120
- menus, diagram 76
- Miscellaneous menu 104
- moving the printer 143
- multipurpose feeder
 - loading 55
- N**
- NetWare menu 95
- Network <x> menu 90
- Network Card menu 92
- Network Reports menu 91
- network setup page
 - printing 34
- Networking Guide 145
- noise
 - reducing 49
- noise emission levels 196
- notices 195, 196, 197, 198, 199, 200, 201
- O**
- options
 - 2,000-sheet tray 30
 - 550-sheet specialty media drawer 30
 - 550-sheet tray 30
 - firmware card 18
 - firmware cards 14
 - flash memory card 18
 - internal 14
 - Internal Solutions Port 20
 - memory card 16
 - memory cards 14
 - networking 14
 - ports 14
 - printer hard disk 26
- ordering
 - fuser or transfer module 133
 - photoconductors 133
 - toner cartridges 133
 - waste toner box 134
- P**
- paper
 - characteristics 60
 - letterhead 61
 - preprinted forms 61
 - recycled 47
 - selecting 61
 - setting size 52
 - setting type 52
 - storing 62
 - unacceptable 61
 - Universal Paper Size 87
- paper feed troubleshooting
 - message remains after jam is cleared 177
 - page that jammed does not reprint 177
- paper jams
 - avoiding 148
- paper jams, clearing
 - 200–201 149
 - 202 150
 - 230 153
 - 24x 155
 - 250 156
- Paper Loading menu 86
- Paper Size/Type menu 78
- paper sizes, supported 62
- Paper Texture menu 82
- paper tray
 - loading 52
- paper types
 - duplex support 64
 - supported by printer 64
 - where to load 64
- Paper Weight menu 84
- Parallel <x> menu 98
- PCL Emul menu 121
- PDF menu 120
- photoconductors
 - ordering 133
- PictBridge menu 126
- PictBridge-enabled printing
 - photos 72
- port settings
 - configuring 43
- PostScript menu 120
- Power Saver
 - adjusting 49
- print job
 - canceling from Macintosh 74
 - canceling from the printer control panel 73
 - canceling from Windows 74
- print quality
 - cleaning the printhead lenses 130
 - replacing photoconductors 138
 - replacing the waste toner box 141
- print quality test pages
 - printing 73
- print quality troubleshooting
 - blank pages 178
 - characters have jagged edges 178
 - clipped images 180

- color misregistration 179
- fine horizontal lines 180
- ghost images 180
- gray background 181
- light colored line, white line, or incorrectly colored line 182
- poor transparency quality 189
- print irregularities 183
- print is too dark 183
- print is too light 184
- print quality test pages 177
- repeating defects 185
- skewed print 186
- solid color pages 186
- streaked horizontal lines 186
- streaked vertical lines 187
- toner fog or background shading 187
- toner rubs off 188
- toner specks 189
- uneven print density 190
- print troubleshooting
 - error reading USB drive 170
 - held jobs do not print 171
 - incorrect characters print 172
 - incorrect margins 181
 - job prints from wrong tray 172
 - job prints on wrong paper 172
 - job takes longer than expected 171
 - jobs do not print 170
 - Large jobs do not collate 173
 - multiple-language PDFs do not print 170
 - paper curl 182
 - paper frequently jams 176
 - tray linking does not work 172
 - unexpected page breaks occur 173
- printer
 - configurations 10
 - minimum clearances 8
 - models 10
 - moving 143
 - selecting a location 8
 - setting up in new location 143
 - shipping 144
- printer control panel 12
 - factory defaults, restoring 146
- printer hard disk
 - installing 26
- printer messages
 - 31.yy Missing or defective <color> cartridge 162
 - 32.yy <Color> cartridge part number unsupported by device 162
 - 34 Short paper 162
 - 35 Insufficient memory to support Resource Save feature 162
 - 37 Insufficient memory to collate job 163
 - 37 Insufficient memory, some held jobs deleted 163
 - 37 Insufficient memory, some held jobs will not be restored 163
 - 38 Memory full 163
 - 39 Complex page, some data may not have printed 163
 - 51 Defective flash detected 163
 - 52 Not enough free space in flash memory for resources 164
 - 54 Network <x> software error 164
 - 54 Standard network software error 164
 - 55 Unsupported option in slot 164
 - 56 Parallel port <x> disabled 164
 - 56 Serial port <x> disabled 165
 - 56 Standard USB port disabled 165
 - 57 Configuration change, held jobs were not restored 165
 - 58 Too many disks installed 165
 - 58 Too many flash options installed 165
 - 58 Too many trays attached 166
 - 59 Incompatible tray <x> 166
 - 61 Remove defective hard disk 166
 - 62 Disk full 166
 - 63 Unformatted disk 166
 - 80.xx Fuser life warning 167
 - 80.xx Fuser missing 167
 - 80.xx Fuser near life warning 166
 - 80.xx Replace fuser 167
 - 82 Replace waste toner box 141
 - 82 Waste toner box nearly full 141
 - 82.yy Replace waste toner box 167
- 82.yy Waste toner box missing 167
- 82.yy Waste toner box nearly full 167
- 83.xx Replace transfer module 168
- 83.xx Transfer module life warning 167
- 83.xx Transfer module missing 168
- 83.xx Transfer module near life warning 167
- 84 <color> photoconductor low 138
- 84 <color> photoconductor nearly low 138
- 84 Replace <color> photoconductor 138
- 84.xx <color> photoconductor low 168
- 84.xx <color> photoconductor missing 168
- 84.xx <color> photoconductor nearly low 168
- 84.xx Replace <color> photoconductor 168
- 88 <color> cartridge low 134
- 88 <color> cartridge nearly low 134
- 88 Replace <color> cartridge 134
- 88.1x <color> cartridge nearly low 168
- 88.2x Replace <color> cartridge 169
- 88.yy <color> cartridge low 168
- Change <src> to <custom string> 157
- Change <src> to <custom type name> 157
- Change <src> to <size> 157
- Change <src> to <type> <size> 158
- Close front door 158
- Close top access cover 158
- Disk Corrupted 158
- Insert tray <x> 158
- Load <src> with <custom string> 159
- Load <src> with <custom type name> 158
- Load <src> with <size> 159
- Load <src> with <type> <size> 159

- Load Manual Feeder with <custom string> 160
- Load Manual Feeder with <custom type name> 159
- Load Manual Feeder with <size> 160
- Load Manual Feeder with <type> <size> 160
- Remove all color supplies 161
- Remove Packaging Materials 161
- Remove paper from standard output bin 161
- Restore Held Jobs? 161
- Securely clearing disk space 161
- Some held jobs were not restored 161
- Unsupported disk 161
- Unsupported mode, unplug and change mode 162
- Unsupported USB device, please remove 162
- Unsupported USB hub, please remove 162
- printer options troubleshooting
 - 2,000-sheet drawer 175
 - flash memory card 175
 - hard disk with adapter 175
 - internal print server 176
 - Internal Solutions Port 175
 - memory card 175
 - option not working 173
 - paper trays 174
 - USB/parallel interface card 176
- printer problems, solving basic 169
- printhead lenses
 - cleaning 130
- printing
 - black-and-white 75
 - directory list 73
 - font sample list 72
 - from flash drive 71
 - from Macintosh computer 66
 - from Windows 66
 - installing printer software 34
 - max speed and max yield 75
 - menu settings page 33
 - network setup page 34
 - photos 72
 - print quality test pages 73
 - transparencies 67
 - printing confidential and other held jobs
 - from Macintosh computer 70
 - from Windows 70
 - publications, finding 7
- Q**
 - Quality menu 115
 - Quiet Mode 49
 - print quality troubleshooting 180
- R**
 - recycled paper
 - using 47
 - recycling
 - Lexmark packaging 51
 - Lexmark products 51
 - toner cartridges 51
 - WEEE statement 196
 - Remove all color supplies 161
 - Remove Packaging Materials 161
 - Remove paper from standard output bin 161
 - Repeat print jobs 69
 - printing from Macintosh computer 70
 - printing from Windows 70
 - reports
 - viewing 146
 - Reports menu 88
 - Reserve print jobs 69
 - printing from Macintosh computer 70
 - printing from Windows 70
 - Restore Held Jobs? 161
- S**
 - safety information 5, 6
 - Securely clearing disk space 161
 - Security Audit Log menu 106
 - security lock 12
 - Serial <x> menu 100
 - serial port 45
 - serial printing
 - setting up 45
 - Set Date/Time menu 107
 - setting
 - paper size 52
 - paper type 52
 - TCP/IP address 92
 - setting up
 - serial printing 45
 - setting up the printer
 - on a wired network (Macintosh) 41
 - on a wired network (Windows) 41
 - Settings menu 112
 - shipping the printer 144
 - SMTP Setup menu 102
 - Some held jobs were not restored 161
 - Standard Network menu 90
 - Standard USB menu 96
 - status of supplies, checking 132, 133
 - storing
 - paper 62
 - supplies 132
 - Substitute Size menu 82
 - supplies
 - conserving 47
 - status of 132, 133
 - storing 132
 - Supplies menu 77
 - supplies, ordering
 - fuser or transfer module 133
 - photoconductors 133
 - toner cartridges 133
 - waste toner box 134
 - system board
 - accessing 15
 - system board cover
 - reinstalling 29
- T**
 - TCP/IP menu 92
 - tips
 - card stock 69
 - envelopes 67
 - labels, paper 68
 - toner cartridge(s)
 - replacing 134
 - toner cartridges
 - ordering 133
 - recycling 51
 - transparencies
 - loading 55
 - printing 67
 - tray linking 58, 59
 - tray unlinking 58, 59
 - trays
 - linking 58, 59

- unlinking 58, 59
- troubleshooting
 - checking an unresponsive printer 169
 - contacting Customer Support 193
 - FAQ about color printing 190
 - solving basic printer problems 169
- troubleshooting, display
 - display is blank 170
 - display shows only diamonds 170
- troubleshooting, paper feed
 - message remains after jam is cleared 177
 - page that jammed does not reprint 177
- troubleshooting, print
 - error reading USB drive 170
 - held jobs do not print 171
 - incorrect characters print 172
 - incorrect margins 181
 - job prints from wrong tray 172
 - job prints on wrong paper 172
 - job takes longer than expected 171
 - jobs do not print 170
 - Large jobs do not collate 173
 - multiple-language PDFs do not print 170
 - paper curl 182
 - paper frequently jams 176
 - tray linking does not work 172
 - unexpected page breaks occur 173
- troubleshooting, print quality
 - blank pages 178
 - characters have jagged edges 178
 - clipped images 180
 - color misregistration 179
 - fine horizontal lines 180
 - ghost images 180
 - gray background 181
 - light colored line, white line, or incorrectly colored line 182
 - poor transparency quality 189
 - print irregularities 183
 - print is too dark 183
 - print is too light 184
 - print quality test pages 177
 - repeating defects 185
 - skewed print 186
 - solid color pages 186

- streaked horizontal lines 186
- streaked vertical lines 187
- toner fog or background shading 187
- toner rubs off 188
- toner specks 189
- uneven print density 190
- troubleshooting, printer options
 - 2,000-sheet drawer 175
 - flash memory card 175
 - hard disk with adapter 175
 - internal print server 176
 - Internal Solutions Port 175
 - memory card 175
 - option not working 173
 - paper trays 174
 - USB/parallel interface card 176

U

- Universal Paper Size 87
- Universal Setup menu 87
- unlinking trays 58
- Unsupported disk 161
- Unsupported mode, unplug and change mode 162
- Unsupported USB device, please remove 162
- Unsupported USB hub, please remove 162
- USB port 32
- Utilities menu 119

V

- Verify print jobs 69
 - printing from Macintosh computer 70
 - printing from Windows 70
- viewing
 - reports 146
- virtual display
 - how to access 145

W

- waste toner box
 - ordering 134
 - replacing 141
- Web site
 - finding 7
- Windows
 - wireless network installation 36

- wired network setup
 - using Windows 41
- wired networking
 - using Macintosh 41
- Wireless menu 94
- wireless network
 - configuration information 36
 - installation, using Macintosh 38
 - installation, using Windows 36

X

- XPS menu 120