

Lexmark™ C935 Clearing Jams Guide

Troubleshooting

Checking an unresponsive printer

If your printer is not responding, make sure:

- The power cord is plugged into the printer and a properly grounded electrical outlet.
- The electrical outlet is not turned off by any switch or breaker.
- The *Ground Fault Circuit Interrupter* (GFCI) has not tripped.

From the back of the printer, press the GFCI **Reset** button located above the printer power cord.

- The printer is not plugged into any surge protectors, uninterrupted power supplies, or extension cords.
- Other electrical equipment plugged into the outlet is working.
- The printer is turned on.
- The printer cable is securely attached to the printer and the host computer, print server, option, or other network device.

Once you have checked each of these possibilities, turn the printer off and then back on. This often fixes the problem.

Door A will not shut properly

Make sure the green paper jam clearance lever behind Door A is in place:

- 1 Press down on the white release lever beneath Door A at the top of the printer, and then open the door.

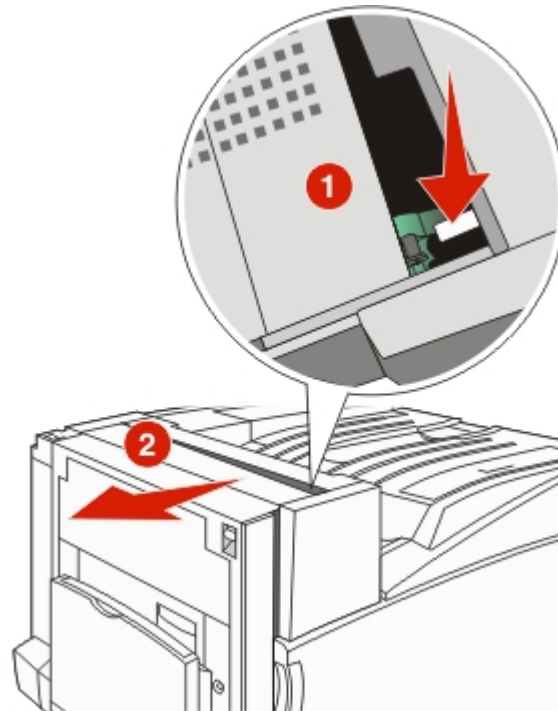

- 2 Press the A1 green lever down to its normal position.

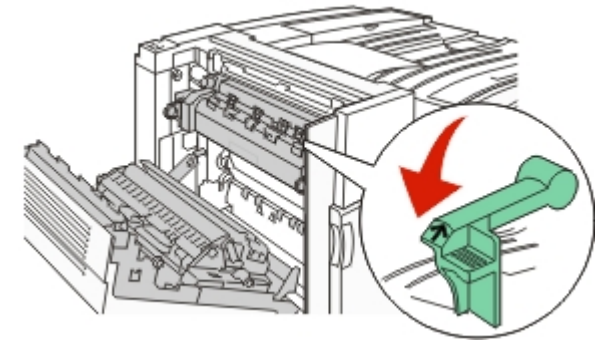

- 3 Close Door A.

Solving printing problems

Multiple-language PDFs do not print

The documents contain unavailable fonts.

- 1 Open the document you want to print in Adobe Acrobat.
- 2 Click the printer icon.
The Print dialog appears.
- 3 Select **Print as image**.
- 4 Click **OK**.

Control panel display is blank or displays only diamonds

The printer self test failed. Turn the printer off, wait about 10 seconds, and then turn the printer back on.

If **Performing Self Test** and **Ready** do not appear, turn the printer off and contact Customer Support.

Error message about reading USB drive appears

Make sure the USB drive is supported. For information regarding tested and approved USB flash memory devices, visit the Lexmark Web site at www.lexmark.com.

Jobs do not print

These are possible solutions. Try one or more of the following:

MAKE SURE THE PRINTER IS READY TO PRINT

Make sure **Ready** or **Power Saver** appears on the display before sending a job to print. Press  to return the printer to the **Ready** state.

CHECK TO SEE IF THE STANDARD EXIT BIN IS FULL

Remove the stack of paper from the standard exit bin, and then press .

CHECK TO SEE IF THE PAPER TRAY IS EMPTY

Load paper in the tray.

MAKE SURE THE CORRECT PRINTER SOFTWARE IS INSTALLED

- Verify that you are using the correct printer software.
- If you are using a USB port, make sure you are running Windows Vista, Windows XP, Windows Server 2003, Windows 2000/98/Me and using compatible printer software.

MAKE SURE THE INTERNAL PRINT SERVER IS INSTALLED PROPERLY AND WORKING

- Make sure the internal print server is properly installed and that the printer is connected to the network. For more information about installing a network printer, click **View User's Guide and Documentation** on the *Software and Documentation* CD.
- Print a network setup page and check that the status shows **Connected**. If the status is **Not Connected**, check the network cables, and then try printing the network setup page again. Contact your system support person to make sure the network is functioning correctly.

Copies of the printer software are also available on the Lexmark Web site at www.lexmark.com.

MAKE SURE YOU ARE USING A RECOMMENDED USB, SERIAL, OR ETHERNET CABLE

For more information, visit the Lexmark Web site at www.lexmark.com.

MAKE SURE PRINTER CABLES ARE SECURELY CONNECTED

Check the cable connections to the printer and print server to make sure they are secure.

For more information, see the setup documentation that came with the printer.

Confidential and other held jobs do not print

These are possible solutions. Try one or more of the following:

HAS A FORMATTING ERROR OCCURRED?

If so, delete the job and try printing it again. Only part of the job may print.

MAKE SURE THE PRINTER HAS SUFFICIENT MEMORY

Free up additional printer memory by scrolling through the list of held jobs and deleting some of them.

CHECK TO SEE IF THE PRINTER HAS RECEIVED INVALID DATA

Delete invalid jobs.

















Job takes longer than expected to print

These are possible solutions. Try one or more of the following:

REDUCE THE COMPLEXITY OF THE PRINT JOB

Eliminate the number and size of fonts, the number and complexity of images, and the number of pages in the job.

CHANGE THE PAGE PROTECT SETTING TO OFF

- 1 From the control panel, press .
- 2 Press  until  **Settings** appears, and then press .
- 3 Press  until  **Setup Menu** appears, and then press .
- 4 Press  until  **Print Recovery** appears, and then press .
- 5 Press  until  **Page Protect** appears, and then press .
- 6 Press  until  **OFF** appears, and then press .

Job prints from the wrong tray or on the wrong paper

CHECK THE PAPER TYPE SETTING

Make sure the Paper Type setting matches the paper loaded in the tray.

Incorrect characters print

Make sure the printer is not in Hex Trace mode. If **Ready Hex** appears on the display, you must exit Hex Trace mode before you can print your job. Turn the printer off and back on to exit Hex Trace mode.

Tray linking does not work

ARE THE SAME SIZE AND TYPE OF PAPER LOADED IN EACH TRAY?

- Load the same size and type of paper in each tray.
- Move the paper guides to the correct positions for the paper size loaded in each tray.

ARE THE PAPER SIZE AND PAPER TYPE SETTINGS THE SAME FOR EACH TRAY?

- Print a menu settings page and compare the settings for each tray.
- If necessary, adjust the settings from the Paper Size/Type menu.

Note: The multipurpose feeder does not automatically sense the paper size. You must set the size from the Paper Size/Type menu.

Large jobs do not collate

These are possible solutions. Try one or more of the following:

MAKE SURE COLLATE IS SET TO ON

From the Finishing menu or Print Properties, set Collate to On.

Note: Setting Collate to Off in the software overrides the setting in the Finishing menu.

REDUCE THE COMPLEXITY OF THE PRINT JOB















Reduce the complexity of the print job by eliminating the number and size of fonts, the number and complexity of images, and the number of pages in the job.

MAKE SURE THE PRINTER HAS ENOUGH MEMORY

Add printer memory or an optional hard disk.

Unexpected page breaks occur

Increase the Print Timeout value:

- 1 From the control panel, press .
- 2 Press  until  **Settings** appears, and then press .
- 3 Press  until  **Setup Menu** appears, and then press .
- 4 Press  until  **Timeouts** appears, and then press .
- 5 Press  until  **Print Timeout** appears, and then press .
- 6 Press  until the desired value appears, and then press .

Solving option problems

Option does not operate correctly or quits after it is installed

These are possible solutions. Try one or more of the following:

RESET THE PRINTER

Turn the printer off, wait for about 10 seconds, and then turn the printer on.

CHECK TO SEE IF THE OPTION IS CONNECTED TO THE PRINTER

- 1 Turn the printer off.
- 2 Unplug the printer.
- 3 Check the connection between the option and the printer.

MAKE SURE THE OPTION IS INSTALLED

Print a menu settings page and check to see if the option is listed in the Installed Options list. If the option is not listed, reinstall it.

MAKE SURE THE OPTION IS SELECTED

From the program you are using, select the option. Mac OS 9 users should make sure the printer is set up in the Chooser.

Drawers

MAKE SURE THE PAPER IS LOADED CORRECTLY

- 1 Open the paper tray.
- 2 Check for paper jams or misfeeds.
- 3 Make sure paper guides are aligned against the edges of the paper.
- 4 Make sure the paper tray closes properly.
- 5 Close the door.

RESET THE PRINTER

Turn the printer off. Wait 10 seconds. Turn the printer back on.

Finisher

If the finisher does not operate correctly, these are possible solutions. Try one or more of the following:

MAKE SURE THE CONNECTION BETWEEN THE FINISHER AND THE PRINTER IS SECURE

If the finisher is listed on the menu settings page, but paper jams when it exits the printer and enters the finisher, it may not be properly installed. Reinstall the finisher. For more information, see the hardware setup documentation that shipped with the finisher.

MAKE SURE YOU ARE USING A PAPER SIZE THAT IS COMPATIBLE WITH THE FINISHER EXIT BINS

For more information about supported paper sizes, click **View User's Guide and Documentation** on the *Software and Documentation* CD.

Flash memory card

Make sure the flash memory card is securely connected to the printer system board.

Hard disk with adapter

Make sure the hard disk is securely connected to the printer system board.

Internal print server

If the internal print server does not operate correctly, these are possible solutions. Try one or more of the following:

CHECK THE PRINT SERVER CONNECTIONS

- Make sure the internal print server is securely attached to the printer system board.
- Make sure you are using the correct (optional) cable and that it is securely connected.

MAKE SURE THE NETWORK SOFTWARE IS CONFIGURED CORRECTLY

For information about installing software for network printing, click **View User's Guide and Documentation** on the *Software and Documentation* CD.

Memory card

Make sure the memory card is securely connected to the printer system board.

USB/parallel interface card

Check the USB/parallel interface card connections:

- Make sure the USB/parallel interface card is securely connected to the printer system board.
- Make sure you are using the correct cable and that it is securely connected.

Solving paper feed problems

Paper frequently jams

These are possible solutions. Try one or more of the following:

CHECK THE PAPER

Use recommended paper and other specialty media. For more information, see the chapter about paper and specialty media guidelines.

MAKE SURE THERE IS NOT TOO MUCH PAPER IN THE PAPER TRAY

Make sure the stack of paper you load does not exceed the maximum stack height indicated in the tray or on the multipurpose feeder.

CHECK THE PAPER GUIDES

Move the guides in the tray to the correct positions for the paper size loaded.

HAS THE PAPER ABSORBED MOISTURE DUE TO HIGH HUMIDITY?

- Load paper from a fresh package.
- Store paper in its original wrapper until you use it.

Print jobs are not routed to the booklet-maker bin

These are possible solutions. Try one or more of the following:

CHECK THE PAPER

Make sure the paper is loaded in a 520-sheet tray or the multipurpose feeder. If the paper is loaded in the multipurpose feeder, make sure it is loaded short-edge first.

Note: Do not load A4- or letter-size paper in the multipurpose feeder.

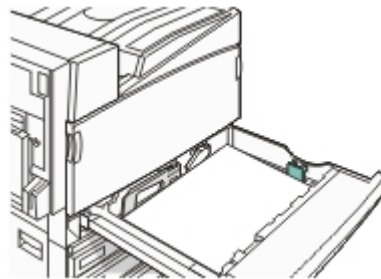

IS THE LETTER- OR A4-SIZE PAPER LOADED IN A 520-SHEET TRAY?

The finisher will not accept letter- or A4-size paper from the multipurpose feeder. Load letter- or A4-size paper in the short-edge orientation in a 520-sheet tray.

MAKE SURE THE PAPER SIZE IS SUPPORTED BY THE BOOKLET-MAKER BIN (BIN 2)

















Use one of the following paper sizes supported by Bin 2: A3, A4, B4, folio, legal, letter, or tabloid (11 x 17 in.).

Paper jam message remains after jam is cleared

The paper path is not clear. Clear jammed paper from the entire paper path, and then press .

Page that jammed does not reprint after you clear the jam

In the Setup menu, Jam Recovery is set to Off. Set Jam Recovery to Auto or On:

- 1 Press .
- 2 Press  until  **Settings** appears, and then press .
- 3 Press  until  **Setup Menu** appears, and then press .
- 4 Press  until  **Print Recovery** appears, and then press .
- 5 Press  until  **Jam Recovery** appears, and then press .
- 6 Press  until  **On** or  **Auto** appears, and then press .

Solving print quality problems

The information in the following topics may help you solve print quality problems. If these suggestions do not correct the problem, contact Customer Support. You may have a printer part that requires adjustment or replacement.

Isolating print quality problems

To help isolate print quality problems, print the print quality test pages:

- 1 Turn the printer off.
- 2 Load letter- or A4-size paper in the tray in the long-edge orientation.

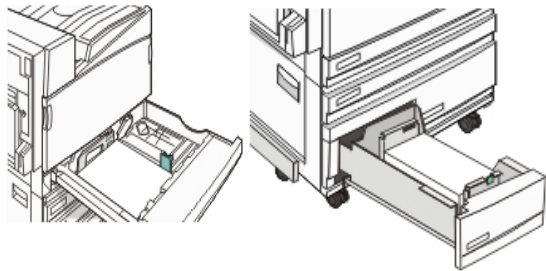

- 3 From the control panel, press and hold and while turning the printer on.
- 4 Release both buttons when **Performing Self Test** appears.
The printer performs its power-on sequence, and then **Config Menu** appears.
- 5 Press until **Prt Quality Pgs** appears, and then press .
- The pages are formatted. **Printing Quality Test Pages** appears, and then the pages print. The message remains on the display until all the pages print.
- 6 After the print quality test pages print, press until **Exit Config Menu** appears, and then press .

Blank pages

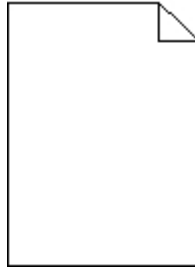

The printer may need to be serviced. For more information, contact Customer Support.

Characters have jagged or uneven edges

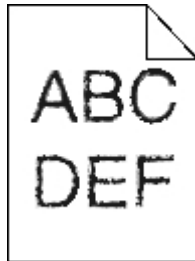

If you are using downloaded fonts, verify that the fonts are supported by the printer, the host computer, and the software program.

Clipped images

These are possible solutions. Try one or more of the following:

CHECK THE PAPER GUIDES

Move the guides in the tray to the correct positions for the paper size loaded.

CHECK THE PAPER SIZE SETTING

Make sure the Paper Size setting matches the paper loaded in the tray.

Dark lines

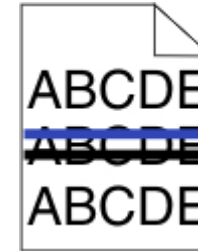

One or more of the photoconductors may be defective.

If an **84 Color pc unit life warning**, **84 Black pc unit life warning**, **84 Replace color pc units**, or **84 Replace black pc unit** message appears, replace the photoconductor(s).

Gray background

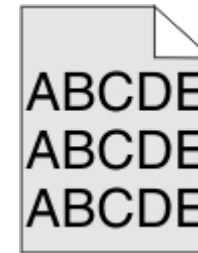

REDUCE THE TONER DARKNESS SETTING

From Print Properties, select a different Toner Darkness setting before sending the job to print.

Incorrect margins



CHECK THE PAPER GUIDES

Move the guides in the tray to the correct positions for the paper size loaded.

CHECK THE PAPER SIZE SETTING

Make sure the Paper Size setting matches the paper loaded in the tray.

CHECK THE PAGE SIZE SETTING

Before sending the job to print, specify the correct page size in Print Properties or the software program.

Light colored line, white line, or incorrectly colored line



These are possible solutions. Try one or more of the following:

CLEAN THE PRINTHEAD LENSES

The printhead lenses may be dirty.

A TONER CARTRIDGE MAY BE DEFECTIVE

Replace the defective toner cartridge.

ARE THE PHOTOCONDUCTORS DEFECTIVE?

Replace the photoconductor(s).

Note: The printer has four photoconductors: cyan, magenta, yellow, and black. The cyan, magenta, and yellow photoconductors must all be replaced at the same time. The black photoconductor can be replaced separately.

Paper curl

These are possible solutions. Try one or more of the following:

CHECK THE PAPER TYPE SETTING

Make sure the Paper Type setting matches the paper loaded in the tray.

HAS THE PAPER ABSORBED MOISTURE DUE TO HIGH HUMIDITY?

- Load paper from a fresh package.
- Store paper in its original wrapper until you use it.

Print irregularities

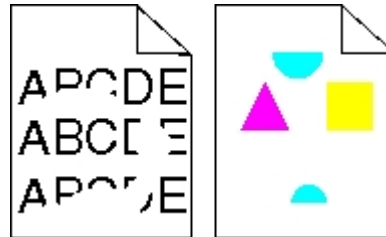

These are possible solutions. Try one or more of the following:

HAS PAPER ABSORBED MOISTURE DUE TO HIGH HUMIDITY?

- Load paper from a fresh package.
- Store paper in its original wrapper until you use it.

CHECK THE PAPER TYPE SETTING

Make sure the Paper Type setting matches the paper loaded in the tray.

CHECK THE PAPER

Avoid textured paper with rough finishes.

IS THE TONER LOW?

When 88 <color> toner low appears, order a new cartridge.

Print is too dark

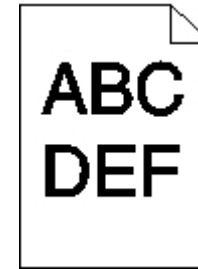

These are possible solutions. Try one or more of the following:

CHECK THE DARKNESS, BRIGHTNESS, AND CONTRAST SETTINGS

The Toner Darkness setting is too dark, the RGB Brightness setting is too dark, or the RGB Contrast setting is too high.

- From Print Properties, change these settings.

Note: This solution applies to Windows users only.

- From the Quality menu, change these settings.

A TONER CARTRIDGE MAY BE DEFECTIVE

Replace the toner cartridge.

Print is too light



These are possible solutions. Try one or more of the following:

CHECK THE DARKNESS, BRIGHTNESS, AND CONTRAST SETTINGS

The Toner Darkness setting is too dark, the RGB Brightness setting is too dark, or the RGB Contrast setting is too high.

- From Print Properties, change these settings.

Note: This solution applies to Windows users only.

- From the Quality menu, change these settings.

HAS THE PAPER ABSORBED MOISTURE DUE TO HIGH HUMIDITY?

- Load paper from a fresh package.
- Store paper in its original wrapper until you use it.

CHECK THE PAPER

Avoid textured paper with rough finishes.

CHECK THE PAPER TYPE SETTING

Make sure the Paper Type setting matches the paper loaded in the tray.

MAKE SURE COLOR SAVER IS SET TO OFF

Color Saver may be set to On.

IS THE TONER LOW?

When 88 <color> toner low appears, order a new cartridge.

A TONER CARTRIDGE MAY BE DEFECTIVE

Replace the toner cartridge.

Repeating defects

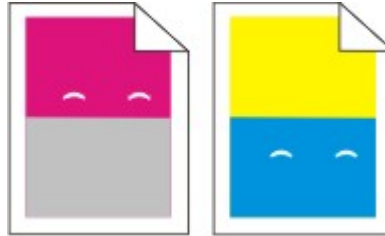

DO MARKS OCCUR REPEATEDLY ONLY IN ONE COLOR AND MULTIPLE TIMES ON A PAGE?

Replace the photoconductor(s) if the defects occur every:

- 44 mm (1.7 in.)
- 94 mm (3.7 in.)

Note: The printer has four photoconductors: cyan, magenta, yellow, and black. The cyan, magenta, and yellow photoconductors must all be replaced at the same time. The black photoconductor can be replaced separately.

Skewed print

CHECK THE PAPER GUIDES

Move the guides in the tray to the correct positions for the paper size loaded.

CHECK THE PAPER

Make sure you are using paper that meets the printer specifications.

Solid color pages



The printer may need to be serviced. For more information, contact Customer Support.

Toner fog or background shading appears on the page

A TONER CARTRIDGE MAY BE DEFECTIVE

Replace the toner cartridge.

ARE THE PHOTOCONDUCTORS WORN OR DEFECTIVE?

Replace the photoconductor(s).

Note: The printer has four photoconductors: cyan, magenta, yellow, and black. The cyan, magenta, and yellow photoconductors must all be replaced at the same time. The black photoconductor can be replaced separately.

IS THERE TONER IN THE PAPER PATH?

Contact Customer Support.

Toner rubs off



These are possible solutions. Try one or more of the following:

CHECK THE PAPER TYPE SETTING

Make sure the Paper Type setting matches the paper loaded in the tray.

CHECK THE PAPER TEXTURE SETTING

Make sure the Paper Texture setting matches the paper loaded in the tray.

Toner specks

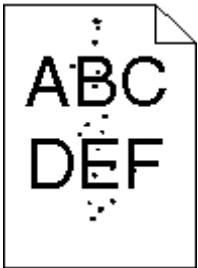

These are possible solutions. Try one or more of the following:

A TONER CARTRIDGE MAY BE DEFECTIVE

Replace the toner cartridge.

IS THERE TONER IN THE PAPER PATH?

Contact Customer Support.

Transparency print quality is poor

CHECK THE TRANSPARENCIES

Use only transparencies recommended by the printer manufacturer.

CHECK THE PAPER TYPE SETTING

Load transparencies, and make sure the Paper Type setting is set to Transparency.

Uneven print density



Replace the photoconductor(s).

Note: The printer has four photoconductors: cyan, magenta, yellow, and black. The cyan, magenta, and yellow photoconductors must all be replaced at the same time. The black photoconductor can be replaced separately.

Solving color quality problems

This section helps answer some basic color-related questions and describes how some of the features provided in the Quality Menu can be used to solve typical color problems.

FAQ about color printing

What is RGB color?

Red, green, and blue light can be added together in various amounts to produce a large range of colors observed in nature. For example, red and green can be combined to create yellow. Televisions and computer monitors create colors in this manner. RGB color is a method of describing colors by indicating the amount of red, green, or blue needed to produce a certain color.

What is CMYK color?

Cyan, magenta, yellow, and black inks or toners can be printed in various amounts to produce a large range of colors observed in nature. For example, cyan and yellow can be combined to create green. Printing presses, inkjet printers, and color laser printers create colors in this manner. CMYK color is a method of describing colors by indicating the amount of cyan, magenta, yellow, and black needed to reproduce a particular color.

How is color specified in a document to be printed?

Software programs typically specify document color using RGB or CMYK color combinations. Additionally, they allow users to

modify the color of each object in a document. For more information, see the software program Help topics.

How does the printer know what color to print?

When a user prints a document, information describing the type and color of each object is sent to the printer. The color information is passed through color conversion tables that translate the color into the appropriate amounts of cyan, magenta, yellow, and black toner needed to produce the desired color. The object information determines the application of color conversion tables. For example, it is possible to apply one type of color conversion table to text while applying a different color conversion table to photographic images.

Should I use PostScript or PCL emulation printer software? What settings should I use for the best color?

The PostScript driver is strongly recommended for best color quality. The default settings in the PostScript driver provide the preferred color quality for the majority of printouts.

Why doesn't the printed color match the color I see on the computer screen?

The color conversion tables used in Auto Color Correction mode generally approximate the colors of a standard computer monitor. However, because of technology differences that exist between printers and monitors, there are many colors that can also be affected by monitor variations and lighting conditions. For recommendations on how the printer color sample pages may be useful in solving certain color-matching problems, see the question, "How can I match a particular color (such as a corporate logo)?"

The printed page appears tinted. Can I adjust the color?

Sometimes a printed page may appear tinted (for example, everything printed seems to be too red). This can be caused by environmental conditions, paper type, lighting conditions, or user preference. In these instances, adjust the Color Balance setting to create a more preferable color. Color Balance provides the user with the ability to make subtle adjustments to the amount of toner being used in each color plane. Selecting positive or negative values for cyan, magenta, yellow, and black (from the Color Balance menu) will slightly increase or decrease the amount of toner used for the chosen color. For example, if a printed page has a red tint, then decreasing both magenta and yellow could potentially improve the color balance.

My color transparencies seem dark when they are projected. Is there anything I can do to improve the color?

This problem most commonly occurs when projecting transparencies with reflective overhead projectors. To obtain the highest projected color quality, transmissive overhead projectors are recommended. If a reflective projector must be used, then adjusting the Toner Darkness setting to 1, 2, or 3 will lighten the transparency. Make sure to print on the recommended type of color transparencies.

What is manual color correction?

When manual color correction is enabled, the printer employs user-selected color conversion tables to process objects. However, Color Correction must be set to Manual, or no user-defined color conversion will be implemented. Manual color correction settings are specific to the type of object being printed (text, graphics, or images), and how the color of the object is specified in the software program (RGB or CMYK combinations).

Notes:

- Manual color correction is not useful if the software program does not specify colors with RGB or CMYK combinations. It is also not effective in situations in which the software program or the computer operating system controls the adjustment of colors.
- The color conversion tables—applied to each object when Color Correction is set to Auto—generate preferred colors for the majority of documents.

To manually apply a different color conversion table:

- 1 From the Quality menu, select **Color Correction**, and then select **Manual**.
- 2 From the Quality menu, select **Manual Color**, and then select the appropriate color conversion table for the affected object type.

Manual Color menu

Object type	Color conversion tables
RGB Image RGB Text RGB Graphics	<ul style="list-style-type: none"> • Vivid—Produces brighter, more saturated colors and may be applied to all incoming color formats. • sRGB Display—Produces an output that approximates the colors displayed on a computer monitor. Black toner usage is optimized for printing photographs. • Display—True Black—Produces an output that approximates the colors displayed on a computer monitor. Uses only black toner to create all levels of neutral gray. • sRGB Vivid—Provides an increased color saturation for the sRGB Display color correction. Black usage is optimized for printing business graphics. • Off—No color correction is implemented.
CMYK Image CMYK Text CMYK Graphics	<ul style="list-style-type: none"> • US CMYK—Applies color correction to approximate the SWOP (Specifications for Web Offset Publishing) color output. • Euro CMYK—Applies color correction to approximated EuroScale color output. • Vivid CMYK—Increases the color saturation of the US CMYK color correction setting. • Off—No color correction is implemented.

How can I match a particular color (such as a corporate logo)?

From the printer Quality menu, nine types of Color Samples sets are available. These are also available from the Color Samples page of the Embedded Web Server. Selecting any sample set generates a multiple-page printout consisting of hundreds of colored boxes. Either a CMYK or RGB combination is located on each box, depending on the table selected. The observed color of each box is obtained by passing the CMYK or RGB combination labeled on the box through the selected color conversion table.

By examining Color Samples sets, a user can identify the box whose color is the closest to the desired color. The color combination labeled on the box can then be used for modifying the color of the object in a software program. For more information, see the software program Help topics. Manual color correction may be necessary to utilize the selected color conversion table for the particular object.

Selecting which Color Samples set to use for a particular color-matching problem depends on the Color Correction setting being used (Auto, Off, or Manual), the type of object being printed (text, graphics, or images), and how the color of the object is specified in the software program (RGB or CMYK combinations). When the printer Color Correction setting is set to Off, the color is based on the print job information; and no color conversion is implemented.

Note: The Color Samples pages are not useful if the software program does not specify colors with RGB or CMYK combinations. Additionally, certain situations exist in which the software program or the computer operating system adjusts the RGB or CMYK combinations specified in the program through color management. The resulting printed color may not be an exact match of the Color Samples pages.

What are detailed Color Samples and how do I access them?

Detailed Color Samples sets are available only through the Embedded Web Server of a network printer. A detailed Color Samples set contains a range of shades (displayed as colored boxes) that are similar to a user-defined RGB or CMYK value. The likeness of the colors in the set are dependent on the value entered in the RGB or CMYK Increment box.

To access a detailed Color Samples set from the Embedded Web Server:

- 1 Open a Web browser.
- 2 In the address bar, type the network printer IP address.
- 3 Click **Configuration**.
- 4 Click **Color Samples**.
- 5 Click **Detailed Options** to narrow the set to one color range.
- 6 When the Detailed Options page appears, select a color conversion table.
- 7 Enter the RGB or CMYK color number.

8 Enter an Increment value from 1–255.

Note: The closer the value is to 1, the narrower the color sample range will appear.

9 Click **Print** to print the detailed Color Samples set.

Contacting Customer Support

When you call Customer Support, describe the problem you are experiencing, the message on the display, and the troubleshooting steps you have already taken to find a solution.

You need to know your printer model type and serial number. For more information, see the label on the inside top front cover of the printer. The serial number is also listed on the menu settings page.

In the U.S. or Canada, call (1-800-539-6275). For other countries/regions, visit the Lexmark Web site at www.lexmark.com.