

Wireless Setup Guide

Edition notice

August 2008

The following paragraph does not apply to any country where such provisions are inconsistent with local law: LEXMARK INTERNATIONAL, INC., PROVIDES THIS PUBLICATION "AS IS" WITHOUT WARRANTY OF ANY KIND, EITHER EXPRESS OR IMPLIED, INCLUDING, BUT NOT LIMITED TO, THE IMPLIED WARRANTIES OF MERCHANTABILITY OR FITNESS FOR A PARTICULAR PURPOSE. Some states do not allow disclaimer of express or implied warranties in certain transactions; therefore, this statement may not apply to you.

This publication could include technical inaccuracies or typographical errors. Changes are periodically made to the information herein; these changes will be incorporated in later editions. Improvements or changes in the products or the programs described may be made at any time.

© 2008 Lexmark International, Inc.

All rights reserved.

UNITED STATES GOVERNMENT RIGHTS

This software and any accompanying documentation provided under this agreement are commercial computer software and documentation developed exclusively at private expense.

Contents

Edition notice	2
Setting up the printer	5
Follow these steps to set up your printer.....	5
Setting up the printer hardware.....	5
Choosing a connection method	9
Preparing to connect wirelessly	10
Information you will need to set up the printer on a wireless network.....	10
Adding the printer to a network using MAC address filtering.....	10
Connecting to a wireless network using Windows	12
Installing the printer on a wireless network (Windows).....	12
Connecting to a wireless network using Macintosh	14
Installing the printer on a wireless network (Macintosh).....	14
Troubleshooting wireless setup	17
Connecting using a USB cable	28
USB setup and connection.....	28
Connecting using an Ethernet network	29
Wired setup and connection.....	29
Networking glossary	30
Index	32

Setting up the printer

Follow these steps to set up your printer

Note: Do not connect cables until instructed.

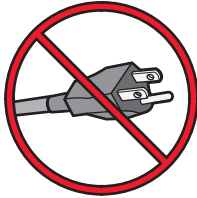

- 1 Set up the printer hardware.
- 2 Decide how you want to connect the printer.

This guide includes three methods:

- Wireless
- Wired (Ethernet)
- Local (USB)

Setting up the printer hardware

1

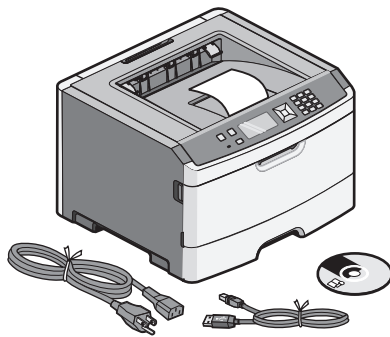

Unpack the printer, cables, and CD.

2

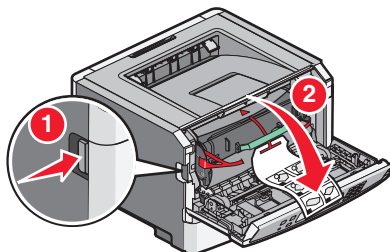

Press the door release button and lower the front door.

3

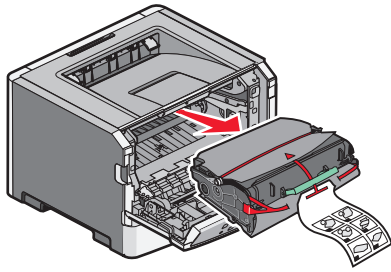

Remove the unit consisting of the photoconductor kit and the toner cartridge from the printer.

4

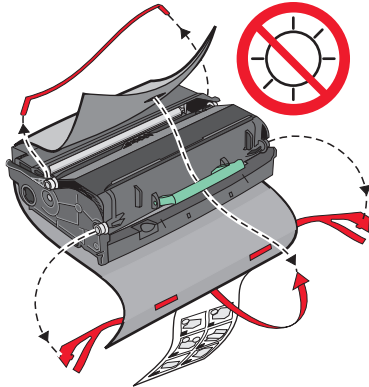

Remove the tape and packaging material from the unit.

5

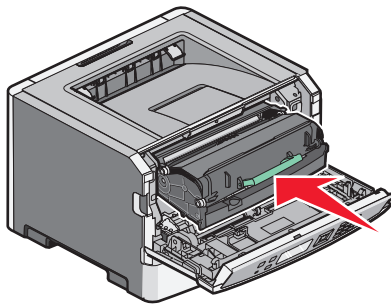

Reinsert the unit into the printer.

6

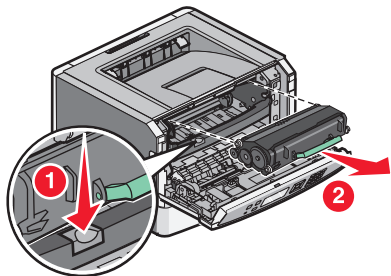

Press the button on the base of the photoconductor kit. Pull the toner cartridge up and out using the handle.

7

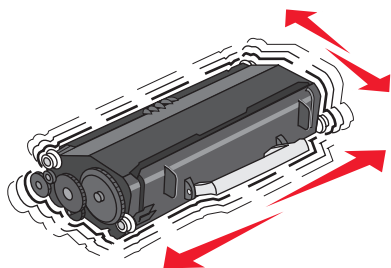

Firmly shake the cartridge side-to-side and front-to-back several times to distribute toner.

8

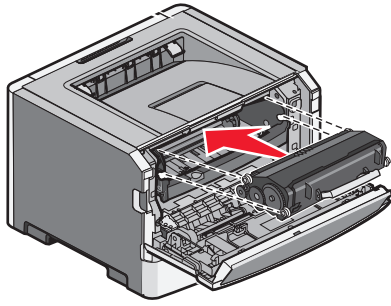

Insert the toner cartridge into the photoconductor kit by aligning the rollers on the toner cartridge with the tracks. Push the toner cartridge until it *clicks* into place.

9

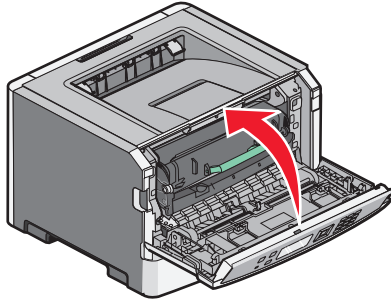

Close the front door.

10

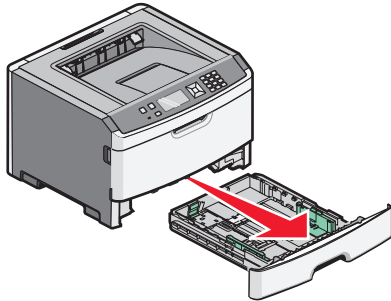

Pull the tray completely out.

11

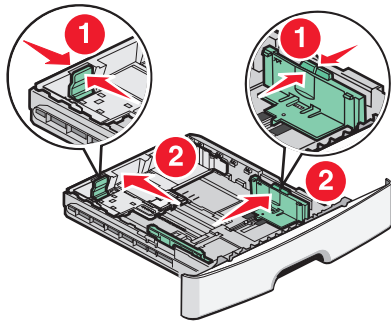

Squeeze the width guide tabs on the right guide as shown, and then slide the width guides to the sides of the tray. Notice that the two width guides move in unison when you move just the right width guide. Squeeze the length guide tabs together as shown, and then slide the length guide to the correct position for the paper size being loaded.

12



Flex the sheets back and forth to loosen them, and then fan them. Do not fold or crease the paper. Straighten the edges on a level surface.

13

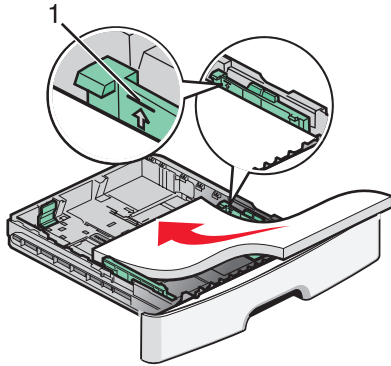

Load the paper stack toward the back on the tray as shown with the recommended print side facedown.

Note: Notice the maximum fill line on the side of the width guide which indicates the maximum height for loading paper. Do not try to overload the tray.

14

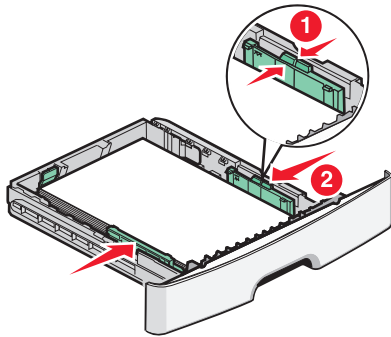

Squeeze the width guide tabs on the right guide, and then slide the width guides to lightly touch the side of the stack.

15

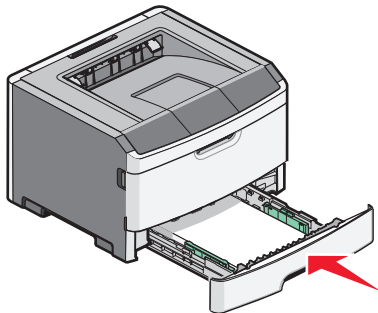

Insert the tray back into the printer.

Choosing a connection method

Note: Do not connect cables until instructed.

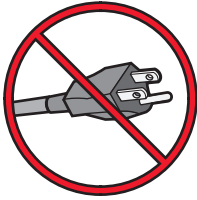

Connect to a wireless network using Windows

For detailed steps, see “Information you will need to set up the printer on a wireless network” on page 10 and “Installing the printer on a wireless network (Windows)” on page 12.

Connect to a wireless network using Macintosh

For detailed steps, see “Information you will need to set up the printer on a wireless network” on page 10 and “Installing the printer on a wireless network (Macintosh)” on page 14.

Connect directly to a computer using a USB cable

For detailed steps, see “Connecting using a USB cable” on page 28.

Connect to a wired network using an Ethernet cable

For detailed steps, see “Connecting using an Ethernet network” on page 29.

Preparing to connect wirelessly

Information you will need to set up the printer on a wireless network

Note: Do not connect the installation or network cables until prompted to do so by the setup software.

- **SSID**—The SSID is also referred to as the network name.
- **Wireless Mode (or Network Mode)**—The mode will be either infrastructure or ad hoc.
- **Channel (for ad hoc networks)**—The channel defaults to auto for infrastructure networks.

Some ad hoc networks will also require the auto setting. Check with your system support person if you are not sure which channel to select.

- **Security Method**—There are three basic options for Security Method:

- WEP key

If your network uses more than one WEP key, enter up to four in the provided spaces. Select the key currently in use on the network by selecting the Default WEP Transmit Key.

or

- WPA or WPA2 passphrase

WPA includes encryption as an additional layer of security. The choices are AES or TKIP. Encryption must be set for the same type on the router and on the printer or the printer will not be able to communicate on the network.

- No security

If your wireless network does not use any type of security, you will not have any security information.

Note: Using an unsecured wireless network is not recommended.

If you are installing the printer on an 802.1X network using the Advanced method, then you may need the following:

- Authentication type
- Inner authentication type
- 802.1X username and password
- Certificates

Note: For more information on configuring 802.1X security, see the *Networking Guide on the Software and Documentation CD*.

Adding the printer to a network using MAC address filtering

Every network device has a unique hardware identification number to distinguish it from other network devices. This identification number is called the *Media Access Control (MAC)* address.

A list of MAC addresses can be set on a wireless router so that only those devices with matching MAC addresses can join the network. This is called MAC address filtering. When installing the printer on a network that uses MAC address filtering, be sure to add the printer MAC address to the list of addresses allowed by the wireless router. If this address is not specifically allowed on the wireless network, the printer will not work wirelessly.

If the printer has a factory-installed internal print server, the MAC address is a series of letters and numbers located on the MAC address sheet that shipped with the printer.

The MAC address appears in the following format:

00 : 04 : 12 : 34 : 56 : 78

Note: Print a network setup page if you cannot locate the printer MAC address. It will appear in the UAA field on the network setup page. Refer to the *User's Guide* on the *Software and Documentation* CD for more information on printing a network setup page.

Connecting to a wireless network using Windows

Installing the printer on a wireless network (Windows)

Before you install the printer on a wireless network, make sure that:

- Your wireless network is set up and working properly.
- The computer you are using is connected to the same wireless network where you want to set up the printer.

1 Connect the power cable, and then turn the printer on.

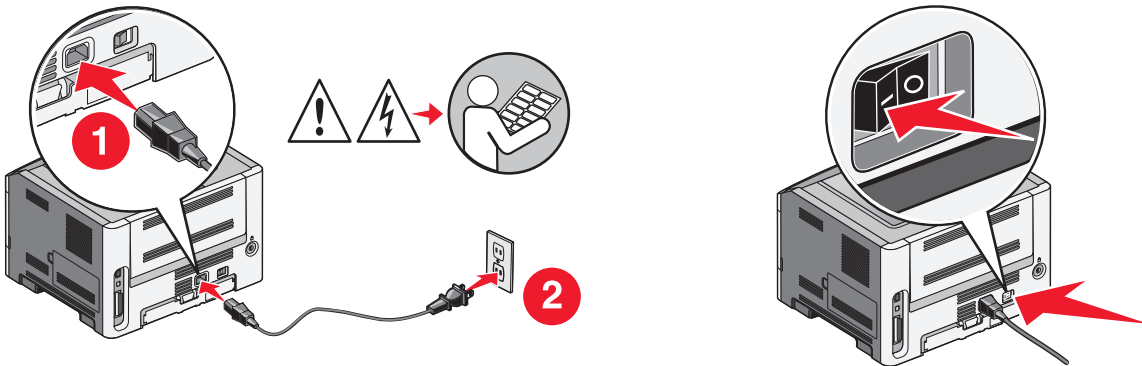

Make sure the printer and computer are fully on and ready.



Do not connect the USB cable until instructed to do so on the screen

2 Insert the *Software and Documentation* CD.

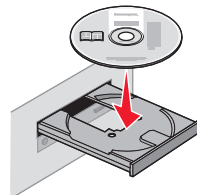

3 Click **Install**.

- 4 Click **Agree**.
- 5 Click **Suggested**.
- 6 Click **Wireless Network Attach**.
- 7 Connect the cables in the following order:
 - a Temporarily connect a USB cable between the computer on the wireless network and the printer.

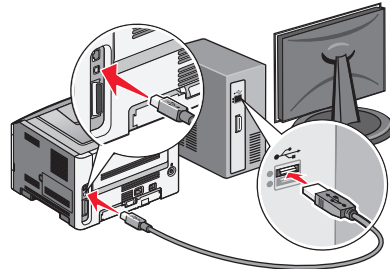

Note: After the printer is configured, the software will instruct you to disconnect the temporary USB cable so you can print wirelessly.

- b If your printer has faxing capabilities, then connect the telephone cable.
- 8 Follow the on-screen instructions to complete the software installation.
- 9 To allow other computers on the wireless network to use the wireless printer, follow steps 2 through 6 and step 8 for each computer.

Connecting to a wireless network using Macintosh

Installing the printer on a wireless network (Macintosh)

Prepare to configure the printer

- 1 Locate the printer MAC address on the sheet that shipped with the printer. Write the last six digits of the MAC address in the space provided below:
MAC address: _____
- 2 If your printer has faxing capabilities, connect the telephone cable.
- 3 Connect the power cable, and turn the power on.

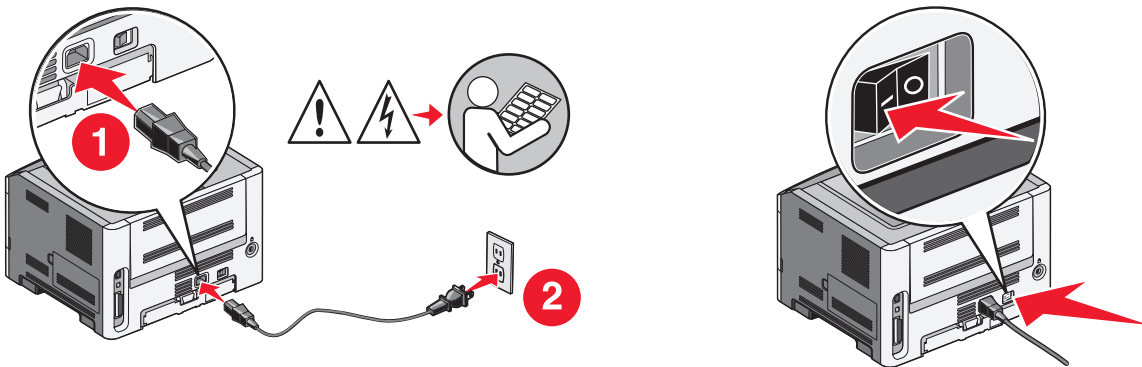

Enter the printer information

- 1 Access the AirPort options.

In Mac OS X version 10.5

- a From the Finder desktop, click **Apple menu** → **System Preferences**.
- b Click **Network**.
- c Click **AirPort**.

In Mac OS X version 10.4 and earlier

- a From the Finder desktop, click **Go** → **Applications**.
- b From the Applications folder, double-click **Internet Connect**.
- c From the toolbar, click **AirPort**.

- 2 From the Network popup menu, select **print server xxxxxx**, where the x's are the last six digits of the MAC address located on the MAC address sheet.

- 3 Open the Safari browser.
- 4 From the Bookmarks drop-down menu, select **Show**.
- 5 Under Collections, select **Bonjour** or **Rendezvous**, and then double-click the printer name.
- 6 From the main page of the Embedded Web Server, navigate to the page where the wireless settings information is stored.

Configure the printer for wireless access

- 1 Type the name of your network (SSID) in the appropriate field.
- 2 Select **Infrastructure** as your Network Mode if you are using a wireless router.
- 3 Select the type of security you use to protect your wireless network.
- 4 Enter the security information necessary for the printer to join your wireless network.
- 5 Click **Submit**.
- 6 Open the AirPort application on your computer:

In Mac OS X version 10.5

- a From the Finder desktop, click **Apple menu → System Preferences**.
- b Click **Network**.
- c Click **AirPort**.

In Mac OS X version 10.4 and earlier

- a From the Finder desktop, click **Go → Applications**.
 - b From the Applications folder, double-click **Internet Connect**.
 - c From the toolbar, click **AirPort**.
- 7 From the Network popup menu, select your wireless network.

Configure your computer to use the printer wirelessly

To print to a network printer, each Macintosh user must install a custom *PostScript Printer Description* (PPD) file and create a printer in the Print Center or Printer Setup Utility.

- 1 Install a PPD file on the computer:
 - a Insert the *Software and Documentation* CD in the CD or DVD drive.
 - b Double-click the installer package for the printer.
 - c From the Welcome screen, click **Continue**.
 - d Click **Continue** again after viewing the Readme file.
 - e Click **Continue** after viewing the license agreement, and then click **Agree** to accept the terms of the agreement.
 - f Select a Destination, and then click **Continue**.
 - g From the Easy Install screen, click **Install**.

- h** Type the user password, and then click **OK**.
All necessary software is installed on the computer.
- i** Click **Close** when installation is complete.

2 Add the printer:

- a** For IP printing:

In Mac OS X version 10.5

- 1** From the Finder desktop, click **Apple menu → System Preferences**.
- 2** Click **Print & Fax**.
- 3** Click **+**.
- 4** Select the printer from the list.
- 5** Click **Add**.

In Mac OS X version 10.4

- 1** From the Finder desktop, click **Go → Applications**.
- 2** Double-click the **Utilities** folder.
- 3** Locate and double-click **Printer Setup Utility** or **Print Center**.
- 4** From the Printer List, choose **Add**.
- 5** Select the printer from the list.
- 6** Click **Add**.

- b** For AppleTalk printing:

In Mac OS X version 10.5

- 1** From the Finder desktop, click **Apple menu → System Preferences**.
- 2** Click **Print & Fax**.
- 3** Click **+**.
- 4** Click **AppleTalk**.
- 5** Select the printer from the list.
- 6** Click **Add**.

In Mac OS X version 10.4

- 1** From the Finder desktop, click **Go → Applications**.
- 2** Double-click the **Utilities** folder.
- 3** Locate and double-click **Print Center** or **Printer Setup Utility**.
- 4** From the Printer List, choose **Add**.
- 5** Choose the **Default Browser** tab.
- 6** Click **More Printers**.
- 7** From the first pop-up menu, choose **AppleTalk**.
- 8** From the second pop-up menu, select **Local AppleTalk zone**.
- 9** Select the printer from the list.
- 10** Click **Add**.

Troubleshooting wireless setup

For more information on networking terms and concepts, refer to the *User's Guide* on the *Software and Documentation CD*.

Wireless troubleshooting checklist

Before beginning to troubleshoot the wireless printer, verify that:

- The printer is turned on and plugged in to a working outlet.
- The SSID is correct.
Print a network setup page to verify the SSID the printer is using.
If you are not sure if the SSID is correct, run the wireless setup again.
- The security information is correct (if your network is secure).
If you are not sure if your security information is correct, run the wireless setup again.
- The wireless network is working properly.
Try accessing other computers on the wireless network.
If the network has Internet access, try connecting to the Internet over a wireless connection.
- The encryption method (AES or TKIP) is the same for the printer as it is for the wireless access point (on networks using WPA security).
- The printer is within the range of the wireless network.
For most networks, the printer should be within 100 feet (30 meters) of the wireless access point (wireless router).
- The printer is located away from obstacles that could block the wireless signal.
Remove any large metal objects between the access point and the printer.
Make sure the printer and wireless access point are not separated by poles, walls, or support columns containing metal or concrete.
- The printer is located away from other electronic devices that may interfere with the wireless signal.
Many devices can interfere with the wireless signal, including baby monitors, motors, cordless phones, security system cameras, other wireless networks, and some Bluetooth devices.
- The printer driver is installed on the computer from which you are performing a task.
- The correct printer port is selected.
- The computer and printer are both connected to the same wireless network.

Printing a network setup page

A network setup page lists the configuration settings of the printer, including the IP address and MAC address. This information is very helpful when troubleshooting the network configuration of the printer.

For more information on printing a network setup page, refer to the *User's Guide* on the installation software CD.

Cannot print over wireless network

If you encountered problems while installing, or if your printer does not appear in the printers folder or as a printer option when sending a print job, you can try uninstalling and reinstalling the software.

These are possible solutions. Try one or more of the following:

MAKE SURE YOUR COMPUTER IS CONNECTED TO YOUR WIRELESS ACCESS POINT (WIRELESS ROUTER)

- See if you have access to the Internet by opening your Web browser and accessing any site.
- If there are other computers or resources on your wireless network, check to see if you can access them from your computer.

MOVE THE COMPUTER AND/OR PRINTER CLOSER TO THE WIRELESS ROUTER

Although the possible distance between devices in 802.11b or 802.11g networks is 300 feet, the maximum range for optimal performance is generally 100–150 feet.

MOVE YOUR ACCESS POINT TO MINIMIZE INTERFERENCE

There may be temporary interference from other devices such as microwave ovens or other appliances, cordless phones, baby monitors, and security system cameras. Make sure your access point is not positioned too closely to these devices.

CHECK WHETHER THE PRINTER IS ON THE SAME WIRELESS NETWORK AS THE COMPUTER

Print a network setup page. Refer to the documentation that came with your printer for details on printing a network setup page.

Make sure the SSID the printer is using matches the wireless network SSID. If you are not sure how to find the network SSID, use one of the following:

Using Windows

- 1** Type the IP address of the wireless access point in the address field of your Web browser.

If you do not know the IP address of the wireless access point:

- a** Do one of the following:

In Windows Vista

- 1** Click .
- 2** Click **All Programs → Accessories**.
- 3** Click **Command Prompt**.

In Windows XP and earlier

- 1** Click **Start**.
- 2** Click **All Programs** or **Programs → Accessories → Command Prompt**.

b Type `ipconfig`.

c Press **Enter**.

- The “Default Gateway” entry is typically the wireless access point.
- The IP address appears as four sets of numbers separated by periods, such as 192.168.0.100. Your IP address might also start with the numbers 10 or 169. This is determined by your operating system or wireless network software.

2 Type your user name and password for the wireless access point when prompted.

3 Click **OK**.

4 On the main page, click **Wireless** or another selection where settings are stored. The SSID appears.

5 Write down the SSID, security type, and the WEP key/WPA passphrase (if shown).

Note: Make sure you copy the network information down exactly, including any capital letters.

6 Store the SSID and the WEP key or WPA passphrase in a safe place for future reference.

Using Macintosh with an AirPort base station

In Mac OS X version 10.5

1 From the menu bar, click **Apple menu → System Preferences**.

2 Click **Network**.

3 Click **AirPort**.

The SSID of the network the computer is connected to is displayed in the Network Name pop-up menu.

4 Write down the SSID.

In Mac OS X version 10.4 and earlier

1 From the menu bar, click **Go → Applications**.

2 From the Applications folder, double-click **Internet Connect**.

3 From the toolbar, click **AirPort**.

The SSID of the network the computer is connected to is displayed in the Network pop-up menu.

4 Write down the SSID.

Using Macintosh with a wireless access point

1 Type the IP address of the wireless access point in the address field of your Web browser and continue to Step 2.

If you do not know the IP address of the wireless access point, then do the following:

In Mac OS X version 10.5

a From the menu bar, click **Apple menu → System Preferences**.

b Click **Network**.

c Click **AirPort**.

d Click **Advanced**.

e Click **TCP/IP**.

The "Router" entry is typically the wireless access point.

In Mac OS X version 10.4 and earlier

a From the menu bar, click **Apple menu → System Preferences**.

b Click **Network**.

c From the Show pop-up menu, select **Airport**.

d Click **TCP/IP**.

The "Router" entry is typically the wireless access point.

2 Type your user name and password when prompted.

3 Click **OK**.

4 On the main page, click **Wireless** or another selection where settings are stored. The SSID will be displayed.

5 Write down the SSID, security type and the WEP key/WPA passphrase (if shown).

Notes:

- Make sure you copy the network information down exactly, including any capital letters.
- Store the SSID and the WEP key or WPA passphrase in a safe place for future reference.

CHECK YOUR WEP KEY OR WPA PASSPHRASE

If your wireless access point is using Wireless Equivalent Privacy (WEP) security, the WEP key should be:

- Exactly 10 or 26 hexadecimal characters. Hexadecimal characters are A-F, a-f, and 0-9.

or

- Exactly 5 or 13 ASCII characters. ASCII characters are letters, numbers, and symbols found on a keyboard. ASCII characters in a WEP key are case-sensitive.

If your wireless access point is using Wi-Fi Protected Access (WPA) security the WPA passphrase should be:

- From 8 to 63 ASCII characters. ASCII characters in a WPA passphrase are case-sensitive.

or

- Exactly 64 hexadecimal characters. Hexadecimal characters are A-F, a-f, and 0-9.

Note: If you do not know this information, see the documentation that came with the wireless network, or contact the person who set up your wireless network.

DISCONNECT FROM VPN SESSION

When you are connected to another network through a VPN connection, you will not be able to access the printer over your wireless network. End your VPN session and try printing again.

CHECK YOUR ADVANCED SECURITY SETTINGS

- If you are using MAC address filtering to limit access to your wireless network, you must add the printer MAC address to the list of addresses allowed to connect to the wireless access point.
- If you set the wireless access point to issue a limited number of IP addresses, you must change this so that the printer can be added.

Note: If you do not know how to make these changes, see the documentation that came with the wireless network, or contact the person who set up your wireless network.

Communication with printer lost when connected to Virtual Private Network (VPN)

You will lose your connection to a wireless printer on your local network when connected to most *Virtual Private Networks* (VPNs). Most VPNs allow users to communicate with only the VPN and no other network at the same time. If you would like to have the ability to connect to your local network and to a VPN at the same time, the system support person for the VPN must enable split tunneling. Be aware that some organizations will not allow split tunneling due to security or technical concerns.

Wireless configuration does not continue after the USB cable is attached

Check the USB cable

If the configuration software does not allow you to continue configuring your printer wirelessly after you attach the USB cable, there may be a problem with the cable. Try one or more of the following:

- Make sure that the USB cable is not damaged. If there is any visible damage to the USB cable, try using a new one.
- Attach the cable directly to the computer and the printer. Hubs, switch boxes, and docking stations can sometimes interfere with the USB connection.
- Make sure the USB cable is correctly attached.

- 1 Attach the large, rectangular connector to any USB port on your computer. USB ports may be on the front or the back of the computer, and may be horizontal or vertical.

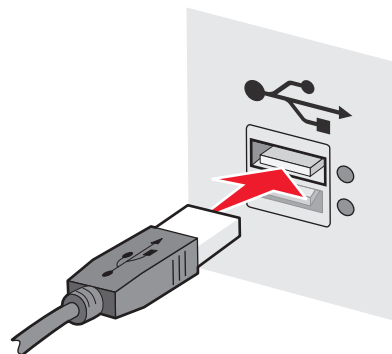

- 2 Attach the small, square connector to the printer.

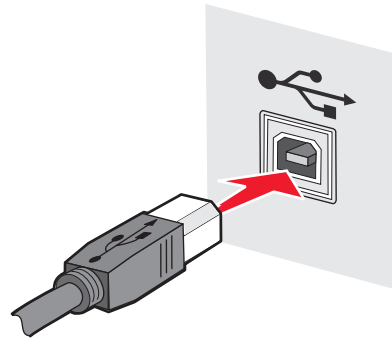

WEP key or WPA pre-shared key not valid

ERROR MADE WHEN ENTERING KEY

- Carefully retype the key.
- Verify that the key has the correct number of characters and the right kind of characters.

WEP key

A valid WEP key must be:

- Exactly 10 or 26 hexadecimal characters. Hexadecimal characters are A-F, a-f, and 0-9.
- or*
- Exactly 5 or 13 ASCII characters. ASCII characters are letters, numbers, and symbols found on a keyboard.

WPA pre-shared key

A valid WPA pre-shared key must be:

- From 8 to 63 ASCII characters. ASCII characters in a WPA pre-shared key are case-sensitive.
- or*
- Exactly 64 hexadecimal characters. Hexadecimal characters are A-F, a-f, and 0-9.

Note: ASCII keys are case-sensitive. Be sure to include any capital letters.

Network does not appear in the Wireless Networks list

There are several reasons why the target network might not appear in the list of networks during printer setup.

NETWORK DOES NOT BROADCAST ITS SSID

Some networks will not appear in the network list because they do not broadcast their SSIDs.

- 1 Select **I want to enter a different network**.
- 2 Click **Next**.

- 3 Enter the SSID, wireless mode, and channel (if ad hoc is selected) information.
- 4 Click **Next** and continue the installation.

THE PRINTER WILL BE MOVED TO A REMOTE NETWORK

- It is not necessary to access the wireless network from the Wireless Networks list if the setup and security information for that network is correct.
- Continue setting up the printer. It will join the remote network when it is moved within proximity of that network:
 - 1 Select **I want to enter a different network**.
 - 2 Click **Next**, and then complete the required network information.

Note: The Wireless Setup Utility will report that the setup was unsuccessful on the last screen, but the printer will be configured correctly for the remote network. To avoid viewing this screen, use the Advanced installation method and select **Do not verify the printer can join the network (for remote installations)**.

THE PRINTER OR INSTALLING COMPUTER IS TOO FAR AWAY FROM THE ACCESS POINT

- Move the printer and/or the computer closer to the access point.
- Add another access point if wireless coverage is necessary in a new area.

THE WIRELESS NETWORK IS NOT FUNCTIONING

Confirm that the network equipment is functioning properly:

- Attempt to connect to other resources on the network.
- Try pinging or logging on to the access point.

Note: If you are unable to communicate with devices on the wireless network, there is a problem with either the configuration of the computer or the wireless network. Contact your system support person, or refer to your access point documentation for assistance.

THERE IS RF (RADIO FREQUENCY) INTERFERENCE BETWEEN THE WIRELESS ACCESS POINT AND THE INSTALLING COMPUTER

Limit the sources of RF interference between the wireless access point and the installing computer by rearranging the network and items in the signal path. Sources of RF interference include:

- Microwave ovens
- Cordless phones
- Ham radios
- Bluetooth devices
- Garage door openers
- Security cameras

Note: Changing the wireless channel that the access point broadcasts on can help resolve interference issues.

THERE IS AN OBJECT BLOCKING THE SIGNAL BETWEEN THE PRINTER AND THE ACCESS POINT

The wireless signal can also be distorted or blocked by objects in the path between the access point and the printer.

- Interior support columns, or walls made of metal or concrete
- Floors
- Room dividers or cubicle walls made of metal
- Large metal filing cabinets, desks, bookcases, or other large metal objects
- Objects containing a large percentage of water, including fish tanks, large plants, stacks of paper, and crowds of people

Note: Place the access point above or in front of any obstacles.

THERE ARE TOO MANY DEVICES ON THE WIRELESS NETWORK

A wireless device will communicate on the network only when no other device is communicating. Too many computers, printers, and other wireless devices can cause a wireless network to be so busy that a new device is unable to send or receive information.

- Adding another access point can help resolve this issue.
- Configure the printer for the network, manually entering all network information. The printer may work properly after it is configured for the network.
- Try turning off a few wireless devices to reduce network traffic.

Wireless Setup Utility unable to communicate with printer

These are possible solutions. Try one or more of the following:

The printer is not powered on

- Turn the printer on.
- Verify that the printer is plugged in to a functioning power strip or electrical outlet.

Note: If the power indicator light is not on, then the printer does not have power.

There is a problem with the USB connection

- Verify that the installation cable is attached to both the computer and the printer.
- Verify that the square end of the installation cable is plugged in to the printer and not the flattened, rectangular end.
- Unplug the USB cable and plug it in again.
- Try a different USB port on the computer. USB ports can be on the back or on the front of the computer.
- Try a different USB cable.

Wireless Setup Utility stops responding during wireless printer configuration

If the Wireless Setup Utility stops responding during the wireless configuration process, restart the computer. Insert the *Software and Documentation* CD and run the Wireless Setup Utility again.

Printer does not print after wireless configuration completes

These are possible solutions. Try one or more of the following:

MAKE SURE THE PRINTER IS TURNED ON

- Verify that printer is turned on and the power light is lit.
- Verify that the printer is plugged in to a functioning power strip or outlet.

VERIFY THAT THE PRINTER IS READY

- Check the status of the printer and verify that it is ready to print.
- If it is not ready, turn the printer off and then back on again.

DISABLE THIRD-PARTY FIREWALLS

- If a non-Microsoft software firewall is installed on the computer, try temporarily disabling it. Check to see if you can print with the firewall disabled. Re-enable the firewall and continue to troubleshoot.
- Update any non-Microsoft firewall software on the computer.
- Add any programs associated with the printer to the firewall whitelist.

VERIFY THAT THE WIRELESS NETWORK IS WORKING PROPERLY

- Try to access other devices on the wireless network to confirm that the network is functioning.
- Contact the system support person to confirm that the network is functioning correctly.

VERIFY THAT THE CORRECT PORT OR PRINTER IS SELECTED

- If you are attempting to print wirelessly, verify that the USB port is not selected.
- If you have more than one instance of the printer installed, verify that the correct printer is selected.

VERIFY THAT WINDOWS IS WORKING PROPERLY

- Try restarting the computer.
- Try installing the printer driver again.
- Try uninstalling, and then reinstalling the printer driver.

VERIFY THAT THE PRINTER IS WORKING

- Insert the *Software and Documentation* CD and set up the printer using a USB connection.
- If the printer works over a USB connection, the printer is working properly.

MAKE SURE THE PRINTER DRIVER IS INSTALLED ON THE PRINTER

All computers that print to the wireless printer must first have the printer driver installed.

- Insert the *Software and Documentation* CD and install the printer driver.

Cannot print and there is a firewall on the computer

Third-party (non-Microsoft) firewalls can interfere with wireless printing. If the printer and computer are configured correctly, and the wireless network is working, but the printer will not print wirelessly, a firewall could be the problem. If there is a firewall (other than the Windows firewall) on the computer, try one or more of the following:

- Update the firewall using the most recent update available from the manufacturer. Refer to the documentation that came with your firewall for instructions on how to do this.
- If programs request firewall access when you install the printer or try to print, make sure you allow those programs to run.
- Temporarily disable the firewall and install the wireless printer on the computer. Re-enable the firewall when you have completed the wireless installation.

Network printer does not show up in the printer selection list during installation

MAKE SURE THE PRINTER IS ON THE SAME WIRELESS NETWORK AS THE COMPUTER

The SSID of the printer must match the SSID of the wireless network.

Find the network SSID

- 1 Type the IP address of your wireless access point into the address field of your browser.
 - a If you do not know the IP address of the wireless access point, do one of the following:

In Windows Vista

- 1 Click .
- 2 Click **All Programs → Accessories**.
- 3 Click **Command Prompt**.

In Windows XP and earlier

- 1 Click **Start**.
- 2 Click **All Programs** or **Programs → Accessories → Command Prompt**.

- b Type `ipconfig`.

c Press **Enter**.

- The “Default Gateway” entry is typically the access point.
- The IP address appears as four sets of numbers separated by periods, such as 192.168.1.1.

2 Type the user name and password for the access point when prompted.

3 Click **OK**.

4 Locate the page where the SSID is displayed.

5 Write down the SSID, security type, and the WEP key or WPA passphrase, if they are shown.

Note: Make sure you copy them down exactly, including any capital letters.

Run the Wireless Setup Utility again

1 Do one of the following:

- In Windows Vista, click .
- In Windows XP and earlier, click **Start**.

2 Click **All Programs** or **Programs**, and then select the printer program folder from the list.

3 Click **Wireless Setup Utility**.

Note: If the Wireless Setup Utility is not installed on the computer, insert the *Software and Documentation CD* and follow the wireless installation path.

4 Follow the instructions on the computer screen, including typing in the SSID of the wireless access point and the WEP key or WPA passphrase when prompted.

Note: You may be prompted to connect the printer to the computer again using the installation cable as part of the setup process.

5 Store the SSID and the WEP key or WPA passphrase in a safe place for future reference.

Connecting using a USB cable

USB setup and connection

1 Insert the *Software and Documentation CD*.

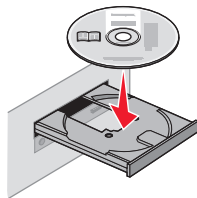

2 Click **Install**.

3 Click **Agree**.

4 Click **Suggested**.

5 Click **Local Attach**.

6 Connect the installation cable to a USB port on the computer and the USB port on the back of the printer.

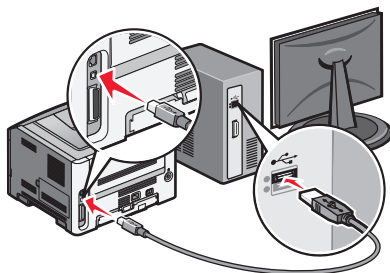

7 Connect the power cable to the printer and plug it into the wall. Turn on the printer.

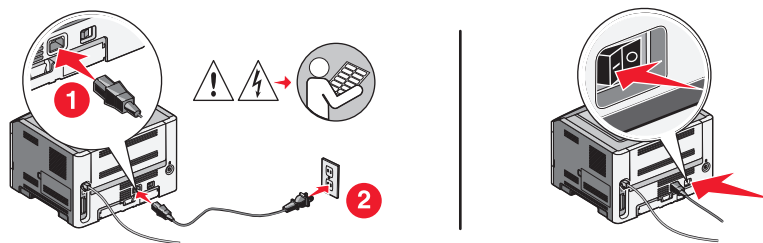

Note: For information on telephone and fax setup, refer to the *User's Guide* on the *Software and Documentation CD*.

Connecting using an Ethernet network

Wired setup and connection

- 1 Insert the *Software and Documentation CD*.

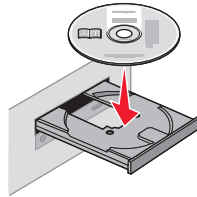

- 2 Click **Install**.

- 3 Click **Agree**.

- 4 Click **Suggested**.

- 5 Click **Wired Network Attach**.

- 6 Connect the Ethernet cable to the printer and to an active Ethernet port on the network.

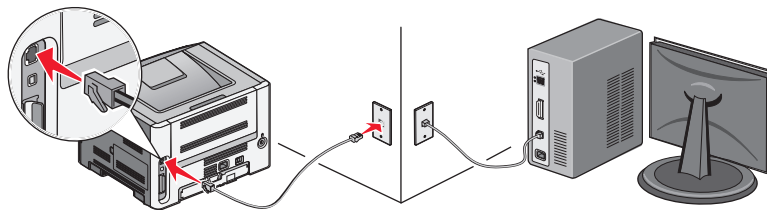

Make sure the computer you are using to configure the printer is attached to a working network port on the same network as the printer.

- 7 Connect the power cord to the printer and plug it into the wall. Turn on the printer.

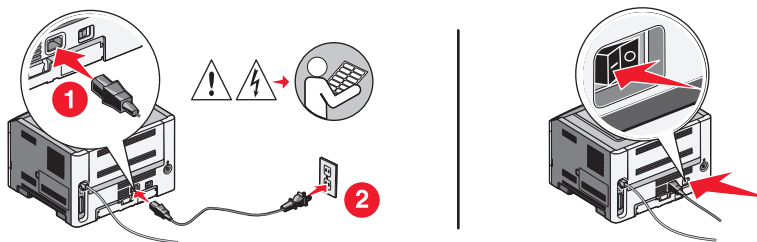

- 8 Follow the on screen instructions to complete the wired configuration.

Note: For information on telephone and fax setup, refer to the *User's Guide* on the *Software and Documentation CD*.

Networking glossary

ad hoc mode	A setting for a wireless device that lets it communicate directly with other wireless devices without an access point or router.
ad hoc network	A wireless network that does not use an access point or router.
AutoIP address	An IP address automatically assigned by a network device. If the device is set to use DHCP, but no DHCP server is available, an AutoIP address may be assigned by the device.
BSS (Basic Service Set)	Basic Service Set describes the type of wireless network that you are using. The BSS type can be one of the following: Infrastructure network or Ad hoc network.
channel	A specific radio frequency used by two or more wireless devices to communicate with each other. All devices on a network must use the same channel.
DHCP (Dynamic Host Configuration Protocol)	A language used by DHCP servers.
DHCP IP address	An IP address automatically assigned by a DHCP server.
DHCP server	A computer or router that assigns a unique IP address to each device on the network.
infrastructure mode	A setting for a wireless device that lets it communicate directly with other wireless devices using an access point or router.
installation cable	Connects the printer to the computer temporarily during some methods of installation.
internal wireless print server	A device that lets computers and printers communicate with each other over a network without cables.
IP (Internet Protocol) address	The network address of a computer or printer. Each device on the network has its own network address. The address may be assigned manually by you (static IP address), automatically by the DHCP server (DHCP IP address), or automatically by the device itself (AutoIP address).
ipconfig	A command that displays the IP address and other network information of a Windows computer.
MAC (Media Access Control) address	A hardware address that uniquely identifies each device on a network. The MAC address for the printer is included on a separate sheet in the box with the printer.
MAC filtering	A method of limiting access to your wireless network by specifying which MAC addresses may communicate on the network. This setting may be specified on wireless routers or access points.
network adapter/card	A device that lets computers or printers attach to a network.
network hub	A device that physically connects multiple devices on a wired network.
network name	See "SSID (Service Set Identifier)" on page 31
ping	A program that tests if your computer can communicate with another networked device.
printer nickname	The name you assign to your printer so that you and others can more easily identify it on the network.

router	A device that shares a single Internet connection with multiple computers or other devices. The router controls network traffic.
security key	A password, such as a WEP key or a WPA passphrase, used to make a network secure.
signal strength	Measure of how strongly a transmitted signal is being received.
SSID (Service Set Identifier)	The name of a wireless network. When you connect a printer to a wireless network, the printer needs to use the same SSID as the network. Also referred to as network name or BSS (Basic Service Set).
static IP address	An IP address assigned manually by you.
switch	A device similar to a network hub that can connect different networks together.
UAA (Universally Administered Address)	An address assigned to a network printer or print server by the manufacturer. This address is associated with the network adapter and is usually the MAC address. To find the UAA, print a network setup page and look for the UAA listing.
USB cable	A lightweight, flexible cable that lets the printer communicate with the computer at much higher speeds than parallel or serial cables.
USB port	A small, rectangular port on the back of the computer that connects the peripheral devices using a USB cable.
WEP (Wired Equivalent Privacy)	A security setting that helps prevent unauthorized access to a wireless network.
wireless access point	A device that connects wireless devices together to form a wireless network.
wireless router	A router that also serves as a wireless access point.
Wi-Fi	An industry term that describes the technology used to create a <i>wireless local area network</i> (WLAN).
WPA (Wi-Fi Protected Access)	A security setting that helps prevent unauthorized access to a wireless network. WPA is not supported on ad hoc wireless networks.
WPA2	A newer version of WPA. Older routers are less likely to support this form of security.

Index

C

- configuration information
 - wireless network 10
- configuring the printer
 - using USB 28
- connection type
 - selecting 9

E

- Ethernet
 - setup 29

F

- finding
 - MAC address 10
- firewall on computer 26

H

- hardware setup 5
- how to
 - print a network setup page 17
- how to set up the printer 5

I

- installation
 - wireless network 12, 14
- installation cable 24

K

- key
 - WEP 22
 - WPA 22

M

- MAC address, finding 10
- Macintosh
 - wireless network installation 14

N

- network printer does not show up in printer selection list during installation (Windows) 26
- network setup page
 - printing 17

P

- power 24
- printer cannot connect to wireless network 18
- printer does not print 25
 - wireless 26

S

- selecting
 - connection type 9
- setting up the printer
 - local connection 28
- steps
 - setting up printer 5

T

- troubleshooting
 - wireless network 17
- troubleshooting, wireless
 - network printer does not show up in printer selection list during installation (Windows) 26
 - printer cannot connect to wireless network 18

U

- unable to communicate 24
- USB 24
 - printer configuration 28

V

- Virtual Private Network 21
- VPN
 - lose connection to printer 21

W

- WEP
 - key 22
- Windows
 - wireless network installation 12
- wired
 - setup 29
- wireless
 - printer does not print 26
 - troubleshooting 21

- wireless installation
 - will not continue after attaching USB cable 21
- wireless interference 22
- wireless network
 - configuration information 10
 - does not appear in network list 22
 - installation, using Macintosh 14
 - installation, using Windows 12
 - troubleshooting 17
- wireless troubleshooting
 - network printer does not show up in printer selection list during installation (Windows) 26
 - printer cannot connect to wireless network 18
 - utility stops responding 25
- WPA
 - key 22