

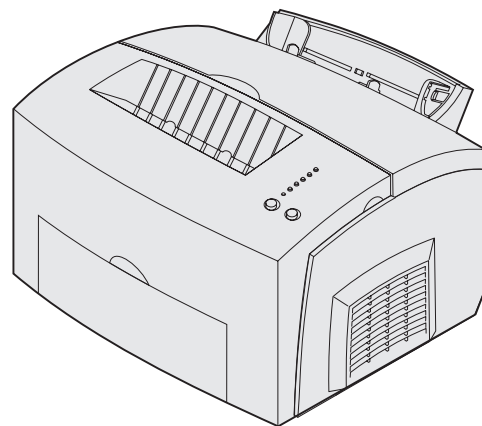

# E220 Printer

---

## Setup Guide



September 2003

## Edition: September 2003

**The following paragraph does not apply to any country where such provisions are inconsistent with local law:** LEXMARK INTERNATIONAL, INC., PROVIDES THIS PUBLICATION "AS IS" WITHOUT WARRANTY OF ANY KIND, EITHER EXPRESS OR IMPLIED, INCLUDING, BUT NOT LIMITED TO, THE IMPLIED WARRANTIES OF MERCHANTABILITY OR FITNESS FOR A PARTICULAR PURPOSE. Some states do not allow disclaimer of express or implied warranties in certain transactions; therefore, this statement may not apply to you.

This publication could include technical inaccuracies or typographical errors. Changes are periodically made to the information herein; these changes will be incorporated in later editions. Improvements or changes in the products or the programs described may be made at any time.

Comments about this publication may be addressed to Lexmark International, Inc., Department F95/032-2, 740 West New Circle Road, Lexington, Kentucky 40550, U.S.A. In the United Kingdom and Eire, send to Lexmark International Ltd., Marketing and Services Department, Westhorpe House, Westhorpe, Marlow Bucks SL7 3RQ. Lexmark may use or distribute any of the information you supply in any way it believes appropriate without incurring any obligation to you. You can purchase additional copies of publications related to this product by calling 1-800-553-9727. In the United Kingdom and Eire, call +44 (0)8704 440 044. In other countries, contact your point of purchase.

References in this publication to products, programs, or services do not imply that the manufacturer intends to make these available in all countries in which it operates. Any reference to a product, program, or service is not intended to state or imply that only that product, program, or service may be used. Any functionally equivalent product, program, or service that does not infringe any existing intellectual property right may be used instead. Evaluation and verification of operation in conjunction with other products, programs, or services, except those expressly designated by the manufacturer, are the user's responsibility.

Lexmark and Lexmark with diamond design are trademarks of Lexmark International, Inc., registered in the United States and/or other countries.

PCL<sup>®</sup> is a registered trademark of the Hewlett-Packard Company.

PostScript<sup>®</sup> is a registered trademark of Adobe Systems Incorporated.

Other trademarks are the property of their respective owners.

© 2003 Lexmark International, Inc.  
All rights reserved.

### UNITED STATES GOVERNMENT RIGHTS

This software and any accompanying documentation provided under this agreement are commercial computer software and documentation developed exclusively at private expense.

### FCC emissions information

This device complies with Part 15 of the FCC Rules. Operation is subject to the following two conditions:

(1) This device may not cause harmful interference, and (2) this device must accept any interference received, including interference that may cause undesired operation.

Any questions on this statement should be directed to:

Director of Lexmark Technology and Services  
Lexmark International, Inc.  
740 West New Circle Road  
Lexington, KY 40550  
(859) 232-3000

Refer to the *Lexmark E220 Publications CD* for more details.

## Safety information

- If your product is *not* marked with this symbol , it *must* be connected to an electrical outlet that is properly grounded. **CAUTION:** Do not set up this product, make electrical connections, or use a fax modem feature during a lightning storm.
- The power cord must be connected to an electrical outlet that is near the product and easily accessible.
- Refer service or repairs, other than those described in the operating instructions, to a professional service person.
- This product is designed, tested, and approved to meet strict global safety standards with the use of specific Lexmark components. The safety features of some parts may not always be obvious. Lexmark is not responsible for the use of other replacement parts.
- Your product uses a laser. **CAUTION:** Use of controls or adjustments or performance of procedures other than those specified herein may result in hazardous radiation exposure.
- Your product uses a printing process that heats the print media, and the heat may cause the media to release emissions. You must understand the section in your operating instructions that discusses the guidelines for selecting print media to avoid the possibility of harmful emissions.

## Conventions

It may help you to recognize the caution, warning, and note conventions used in this book. These appear in the left column for easy reference.

**CAUTION:** A caution identifies something that could cause you harm.

**Warning:** A warning identifies something that could damage your printer hardware or software.

**Note:** A note provides information you may find useful.

# Contents

<b>Introduction</b> .....	<b>v</b>
About the printer .....	v
Other sources of information .....	vii
<b>Step 1: Unpack the printer</b> .....	<b>1</b>
Attaching an operator panel overlay .....	2
<b>Step 2: Install the optional 250-sheet drawer</b> .....	<b>3</b>
<b>Step 3: Install printer supplies</b> .....	<b>5</b>
Installing the print cartridge .....	5
<b>Step 4: Install memory cards</b> .....	<b>8</b>
Removing the printer side cover .....	8
Removing the system board shield .....	10
Installing a memory card .....	10
Reinstalling the system board shield .....	12
Reattaching the printer side cover .....	13
<b>Step 5: Load paper</b> .....	<b>14</b>
Loading tray 1 .....	15
Loading the optional 250-sheet tray .....	18
Loading the manual feed .....	21
<b>Step 6: Attach cables</b> .....	<b>24</b>
USB cable .....	24

Parallel cable .....	25
<b>Step 7: Install drivers for local printing .....</b>	<b>26</b>
Windows .....	27
Macintosh .....	31
UNIX/Linux .....	32
<b>Step 8: Verify printer setup .....</b>	<b>34</b>
Turning on the printer .....	34
Printing a setup page .....	34
<b>Step 9: Distribute information to users .....</b>	<b>35</b>
Identifying printer users .....	35
Locating helpful information .....	35
Distributing the information .....	36
Congratulations! .....	36
<b>Understanding the operator panel lights .....</b>	<b>37</b>
<b>Troubleshooting tips .....</b>	<b>44</b>
<b>Statement of Limited Warranty .....</b>	<b>46</b>

# Introduction

## About the printer

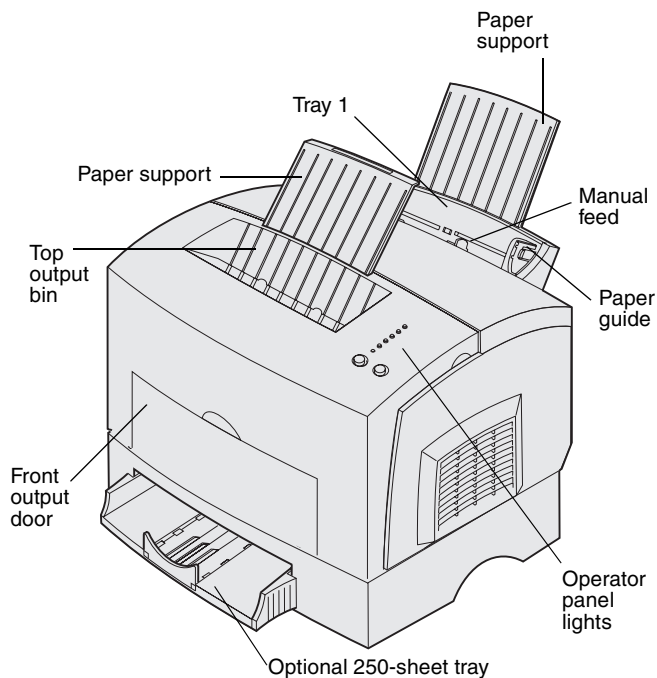

<b>Use this feature:</b>	<b>When you want to:</b>
Tray 1	Load up to 150 sheets of paper or 10 sheets of other media.
Paper support	Support media in tray 1 or the top output bin.
Manual feed	Load a single sheet of paper or other media. Use for transparencies, labels, envelopes, and card stock.

Use this feature:	When you want to:
Paper guides	Adjust the width of the media in tray 1 and the manual feed.
Operator panel lights	Check the status of your printer.
Top output bin	Stack printed documents facedown.
Front output door	Print on special media, for example, labels or card stock.
Optional 250-sheet tray	Increase your paper capacity.

Lexmark E220

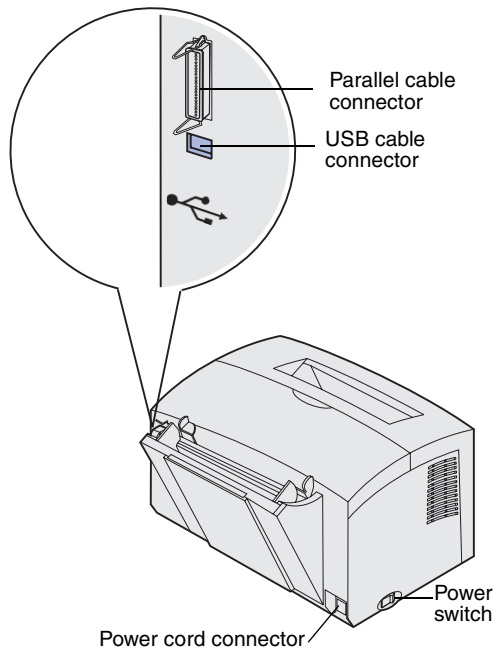

Use this feature:	When you want to:
Parallel cable connector	Connect your computer to the Lexmark E220 parallel port with a parallel cable.
USB cable connector	Connect your computer to your printer USB port with a USB cable.
Power cord connector	Plug your printer into a properly grounded electrical outlet with the power cord (after all other peripherals have been connected).
Power switch	Turn your printer on or off.

## Other sources of information

If you need more information after you have completed setup, refer to the other printer documentation.

### *Publications CD*

The publications CD, which is packaged with the *Setup Guide*, provides information about choosing media, understanding the operator panel lights, clearing paper jams, and solving printing problems.

The information on the publications CD is also available on Lexmark's Web site at **[www.lexmark.com/publications](http://www.lexmark.com/publications)**.

### *Quick Reference card*

The printer *Quick Reference* card provides easy access to information about loading paper, clearing jams, and understanding common operator panel light messages.

### *Drivers CD*

The drivers CD contains the necessary printer drivers to get your printer up and running.

It may also contain printer utilities, screen fonts, and additional documentation.

### *Lexmark's Web site*

Visit our Web site at **[www.lexmark.com](http://www.lexmark.com)** for updated printer drivers, utilities, and other printer documentation.

# Step 1: Unpack the printer

## 1 Select a location for your printer.

- Leave enough room to open the printer cover, output door, and optional 250-sheet tray. It is also important to allow space around the printer for proper ventilation.
- Provide the proper environment:
  - A firm, level surface
  - Away from the direct airflow of air conditioners, heaters, or ventilators
  - Free of sunlight, humidity extremes, or temperature fluctuations
  - Clean, dry, and free of dust

## 2 Remove all items from the box except the printer. Make sure you have the following items:

- Printer with print cartridge installed
- Power cord
- *Setup Guide* with a publications CD
- *Quick Reference* card
- Drivers CD
- Operator panel overlay (non-English only)

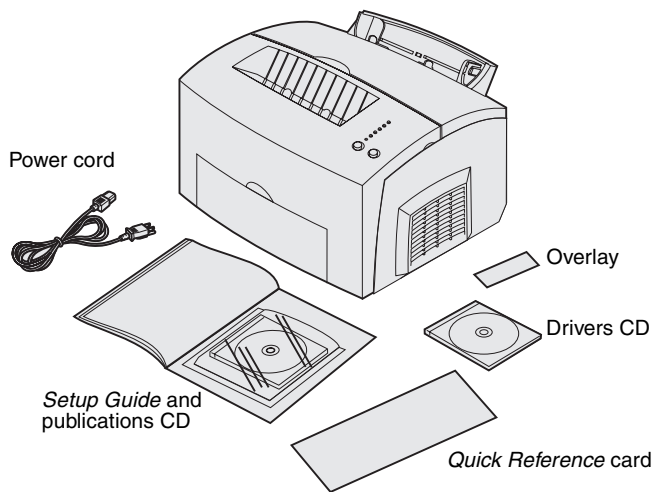

**Note:** The Lexmark E220 comes with a 1,500-page starter print cartridge.



If any items are missing or damaged, refer to our Lexmark Web site at **[www.lexmark.com](http://www.lexmark.com)** for the designated Lexmark support phone number for your country or region.

Save the carton and packing material in case you need to repack the printer.

## **Attaching an operator panel overlay**

If you have a non-English operator panel overlay in your printer box and want to use it, peel it off, align it on the operator panel, and press it into place.

# Step 2: Install the optional 250-sheet drawer

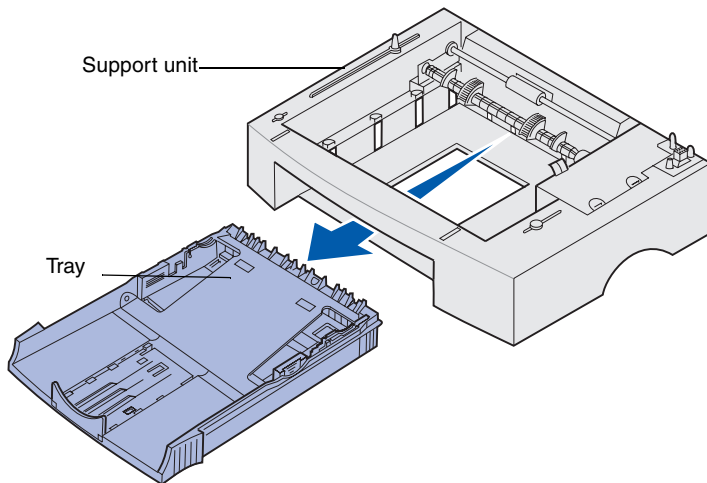

You can increase paper capacity with the optional 250-sheet drawer, which attaches underneath the printer.

A drawer consists of a tray and a support unit.

- 1** Remove the tray from the support unit.
- 2** Remove all packing material and tape from the tray and the support unit.
- 3** Place the support unit in the location you have chosen for your printer.

**Note:** If you install the optional 250-sheet drawer at a later time, be sure to turn off the printer before installing it.

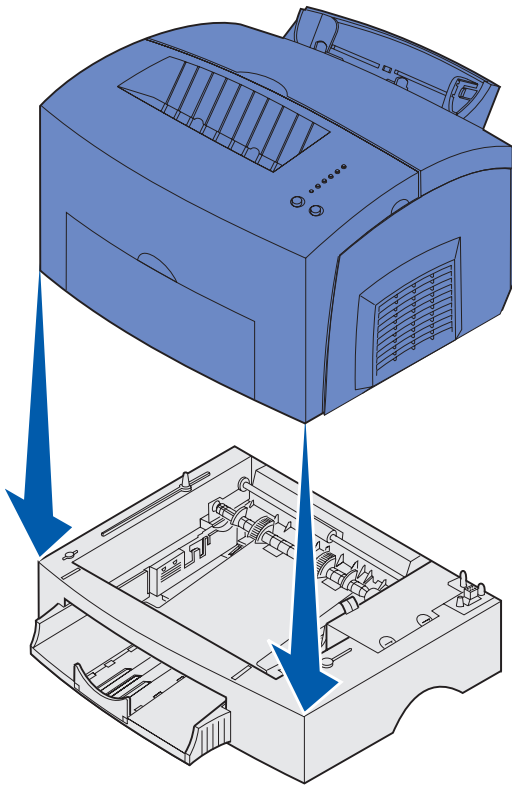

- 4 Align the printer with the front of the support unit and place it on top of the support unit.

Make sure the support unit is firmly in place.

When you complete setting up the printer, print a menu settings page to verify the 250-sheet drawer is listed under Installed Features (see page 34).

- 5 Insert the tray.

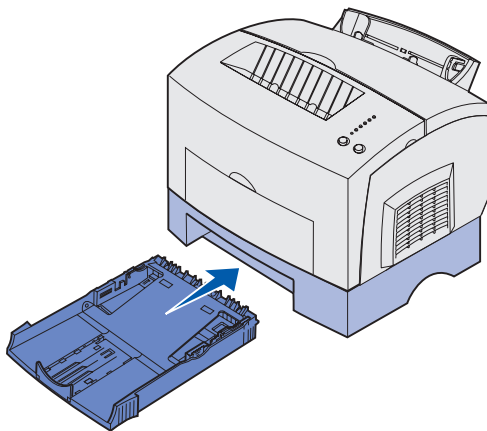

*Install the optional 250-sheet drawer*

# Step 3: Install printer supplies

## Installing the print cartridge

### *Removing print cartridge packaging*

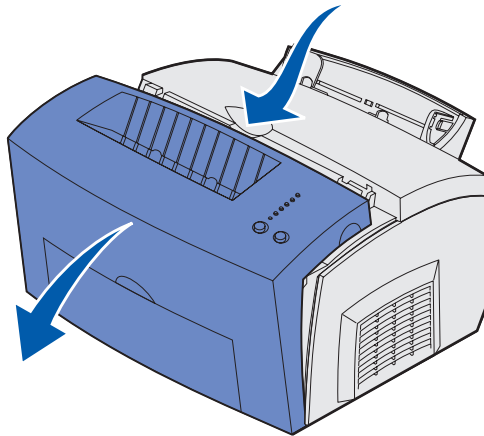

- 1** Use the finger tab to pull down the printer cover.

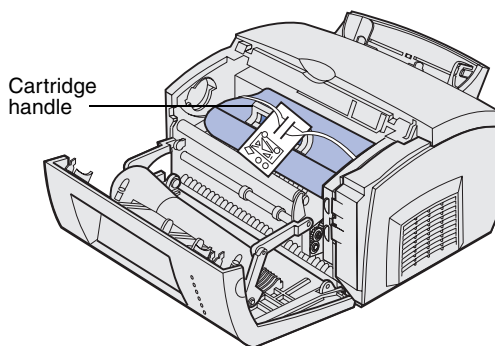

- 2** Grasp the cartridge handle and pull the print cartridge straight up.
- 3** Remove the protective foam packaging from the print cartridge.

- 4 Pull off the plastic piece attached to the ends of the print cartridge.

Discard the plastic piece, foam, and paper.

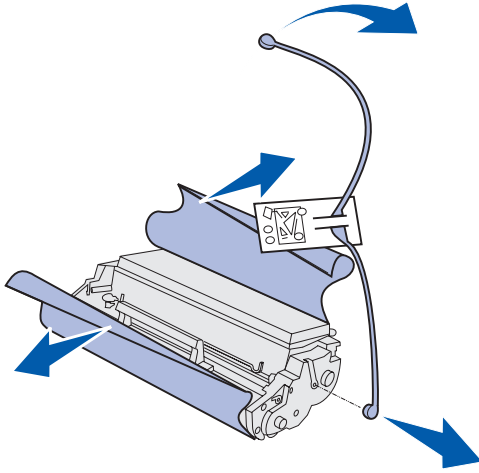

**Note:** Do not touch the photoconductor drum on the bottom of the print cartridge.

- 5 Shake the cartridge to distribute the toner evenly.

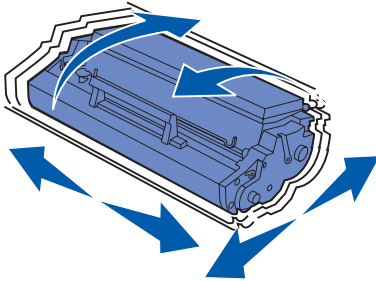

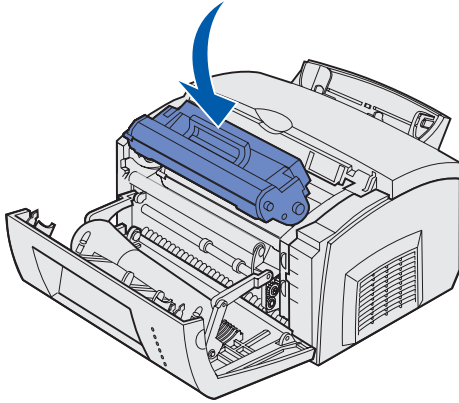

**6** Insert the print cartridge:

- a** Align the colored arrows on either side of the cartridge with the corresponding arrows in the printer.
- b** Holding the cartridge by the handle, tilt the cartridge down and guide it between the print cartridge grooves.
- c** Push down on the cartridge until it is firmly in place.

**7** Close the printer cover.

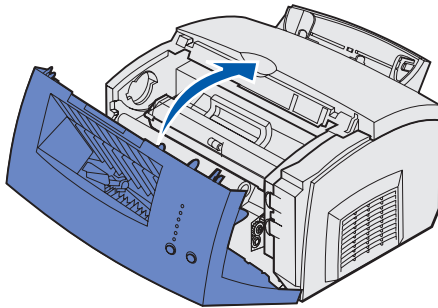

**What do I do next?**

Task	Go to page...
Install memory cards	8
Load paper	14

# Step 4: Install memory cards

You can customize your printer memory capacity and connectivity by adding optional cards.

**CAUTION:** If you are installing memory cards sometime after setting up the printer, turn the printer off and unplug the power cord before continuing.

## Removing the printer side cover

Before installing any memory options, you must remove the printer side cover.

- 1 Open the printer front cover.

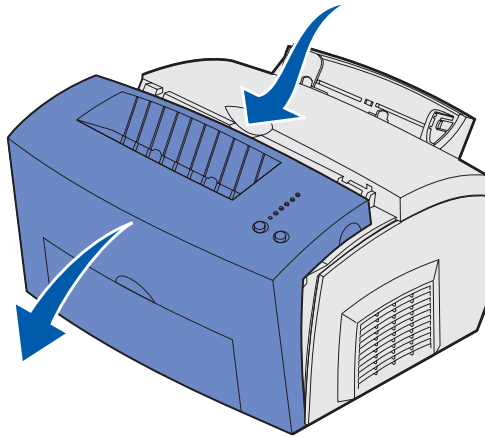

- 2** Firmly push in the two oval tabs as you pull open the side cover.

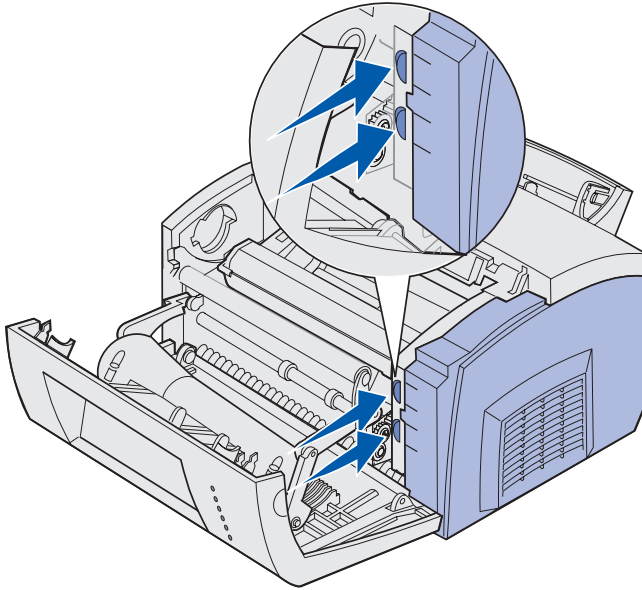

- 3** Gently pull off the cover and set it aside.

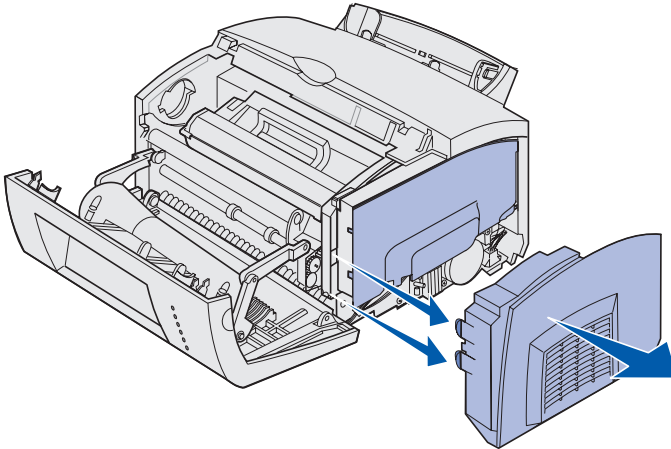

*Install memory cards*



## Removing the system board shield

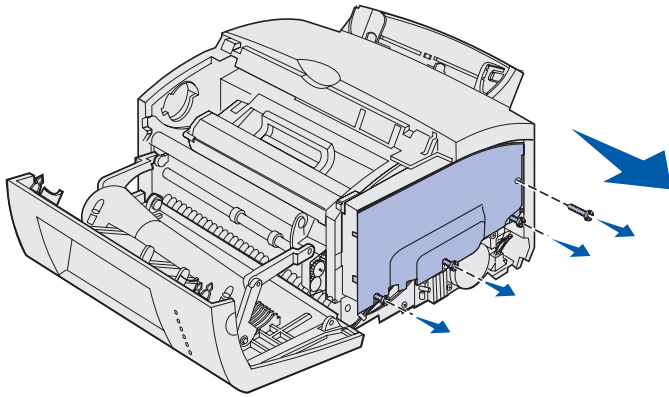

Use a No. 2 Phillips screwdriver to remove the system board shield.

- 1** Remove the top screw and set it aside.
- 2** Loosen the bottom three screws, but do not remove them.

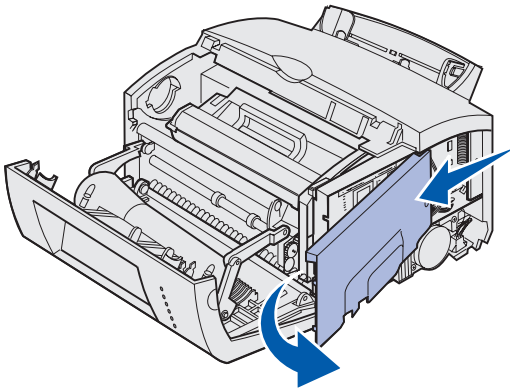

- 3** Slide the system board shield along the top and bottom grooves and set it aside.

## Installing a memory card

Follow the instructions in this section to install a printer memory card.

The system board has two connectors for optional memory cards. You can install a card in either connector.

*Install memory cards*

**Warning:** Memory cards are easily damaged by static electricity. Touch something metal on the printer before you touch a memory card.

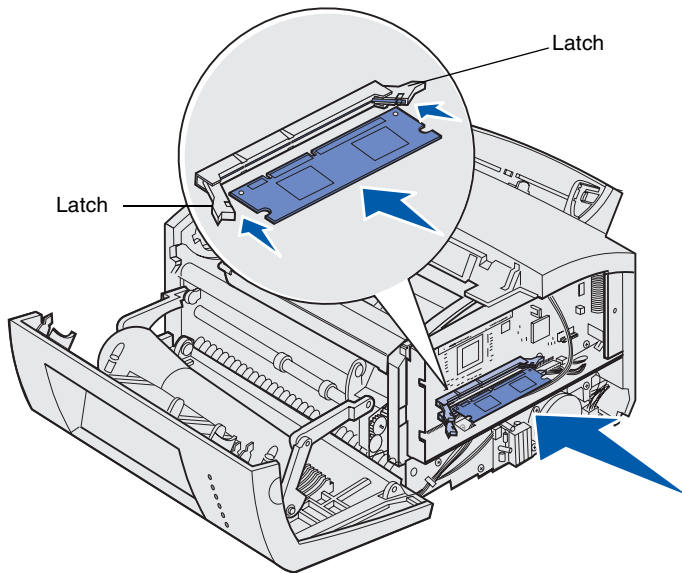
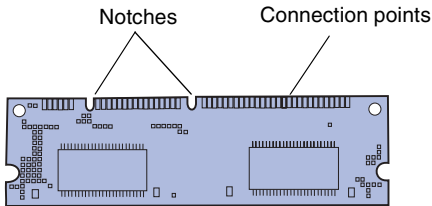

**1** Complete the steps in “Removing the system board shield” on page 10.

**2** Unpack the printer memory card.

Avoid touching the connection points along the edge of the card. Save the packaging.

**3** Align the notches on the bottom of the card with the notches on the connector.

**4** Guide the card between the latches on each end of the connector and push the card firmly into the connector.

**5** Make sure each latch fits over the notch on each end of the memory card.

**6** Reattach the metal shield and side cover. See page 12 for instructions.

## Reinstalling the system board shield

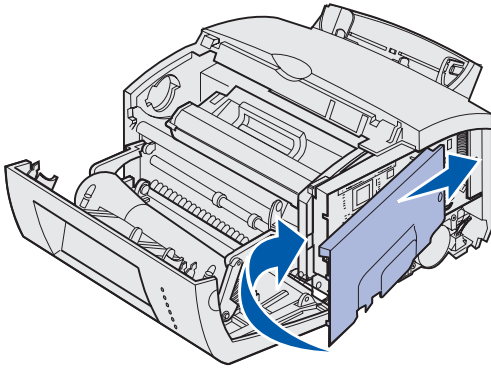

- 1 Align the metal shield between the top and bottom grooves and slide it all the way back.

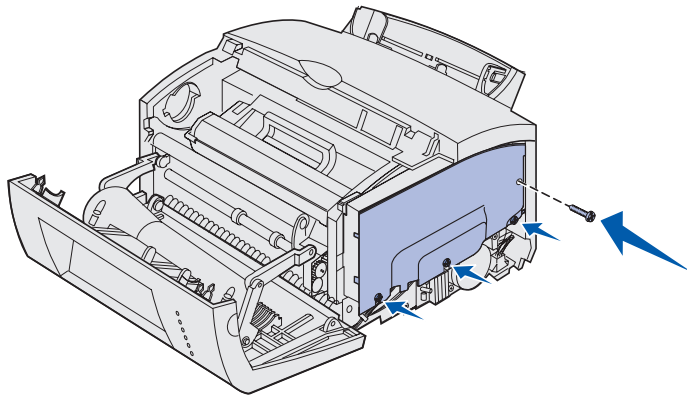

- 2 Tighten the bottom three screws and reattach the top screw to keep the shield in place.

*Install memory cards*

## Reattaching the printer side cover

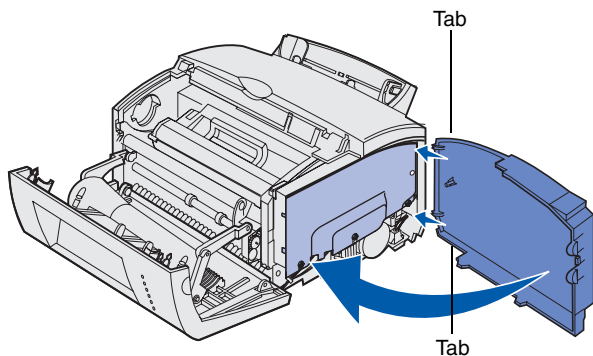

- 1** Align the top and bottom tabs with the corresponding slots.
- 2** As you close the printer side cover, push the oval tabs firmly into the slots.
- 3** Close the printer front cover.

# Step 5: Load paper

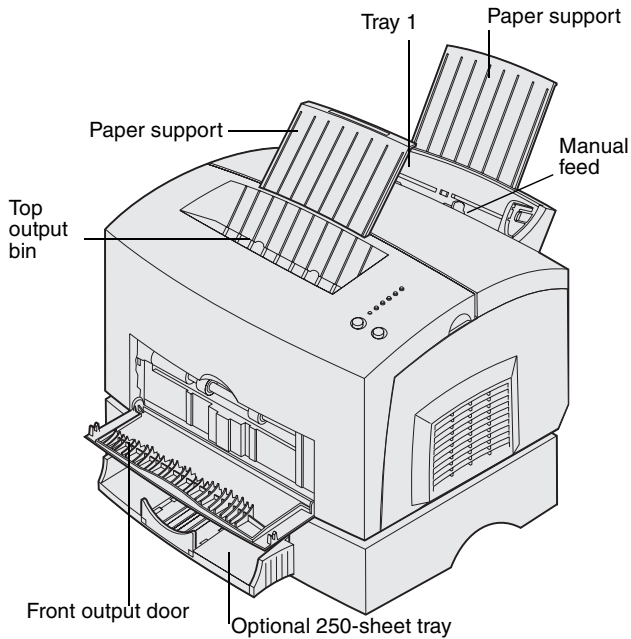

Your printer has two standard paper sources: tray 1, which holds up to 150 sheets of plain paper, and a single-sheet manual feed. Use tray 1 for most print jobs. Use the manual feed to feed a single page, transparency, envelope, label, or card stock.

You can increase your printer paper capacity with the optional 250-sheet tray.

An output bin on top of the printer holds up to 100 sheets. The single-sheet front output door provides a straight-through paper path for special media, reducing curling and potential paper jams.

The following table lists page numbers where you can find loading instructions for each tray.

Source	Capacity (sheets)	Paper sizes supported	Paper types supported	Go to page...
Tray 1	150	A4, A5, B5, letter, legal, executive, folio	Plain paper, transparencies, labels, card stock	<b>15</b>
Optional 250-sheet tray	250		Plain paper	<b>18</b>
Manual feed	1		Plain paper, transparencies, envelopes, labels, card stock	<b>21</b>

## Loading tray 1

Use tray 1, which is behind the manual feed, to feed paper and special media.

Tray 1 holds up to 150 sheets of paper, 10 sheets of transparencies or labels, 10 envelopes, or 10 sheets of card stock.

- 1 Extend the rear paper support until you hear a *click*.

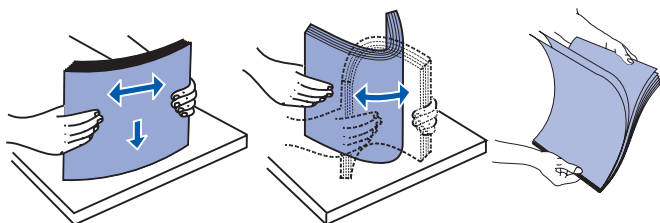
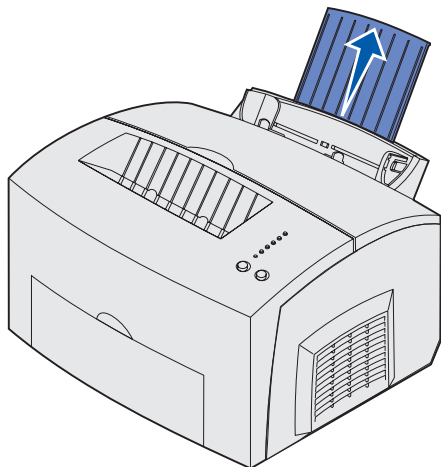

- 2 Flex the sheets back and forth to loosen them, fan the sheets on all four sides, and flex them again.

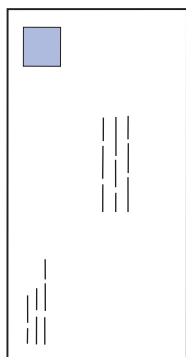
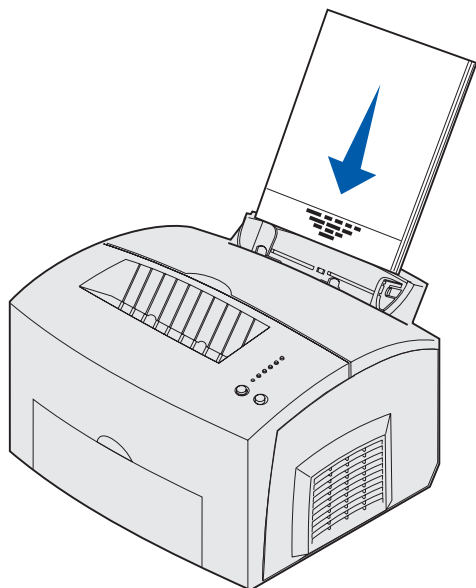

### 3 If loading:

- letterhead paper, insert letterhead with the top of the page pointing down, facing you

- envelopes, insert them vertically, flap side down with the stamp area in the top left corner

To reduce paper jams, do not use envelopes that:

- Have excessive curl
- Are stuck together
- Are damaged in any way
- Contain windows, holes, perforations, cutouts, or embossing
- Use metal clasps, string ties, or metal folding bars
- Have postage stamps attached
- Have any exposed adhesive when the flap is in the sealed position

*Load paper*

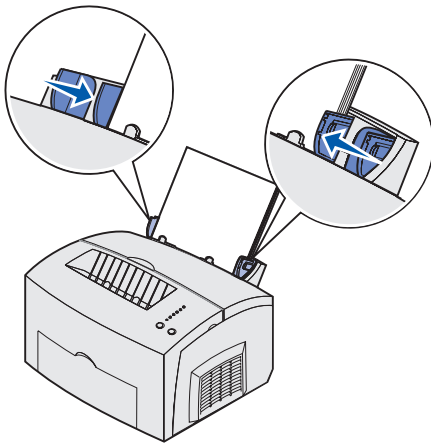
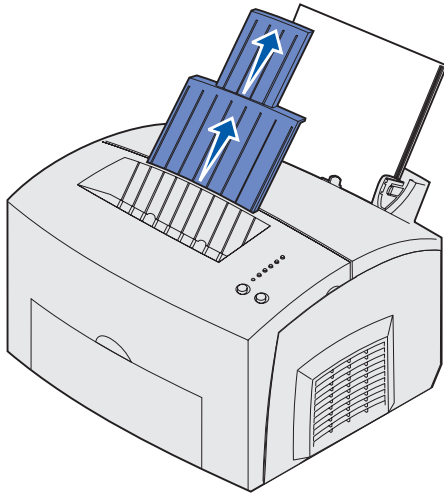

**Note:** If you load any print media other than plain letter or A4 paper in trays 1 or 2, make sure you change the Paper Type and Paper Size settings for that tray. Refer to the publications CD for detailed information.

- 4 Extend the front paper support on the top output bin until you hear a *click*.
- 5 If you are printing on legal size paper, completely extend the front paper support.
- 6 Open the front output door for a straight-through paper path if you are printing on special media.
- 7 Slide the paper guides against the edges of the paper or envelopes.
- 8 Select the paper size and type from your software application.
- 9 Select the number of copies from your software application or printer driver if you are printing multiple copies.
- 10 Start your print job.



## Loading the optional 250-sheet tray

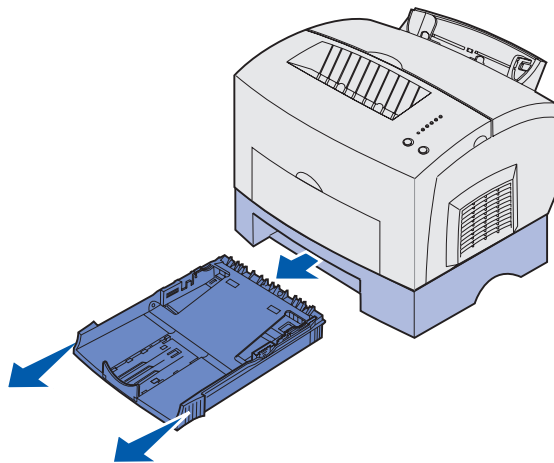

- 1** Grasp the tabs on either side of the tray and pull it completely out of the printer.

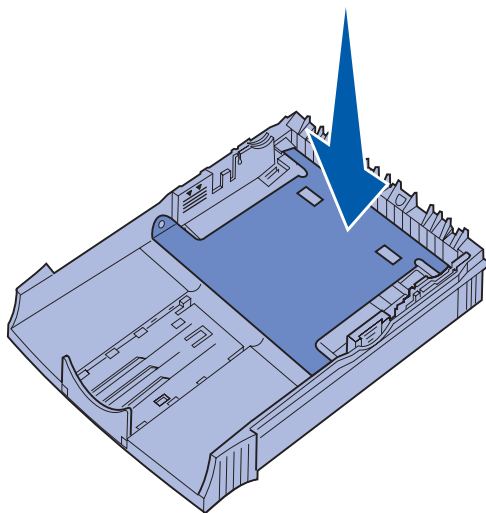

- 2** Make sure the metal plate is pressed down before inserting the tray into the printer.

After the tray is inserted, the metal plate springs back up so the paper can feed into the printer.

- 3 If loading A4 or legal size paper, extend the paper support on the front of the tray.

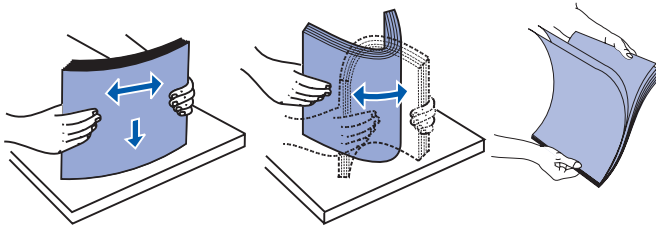
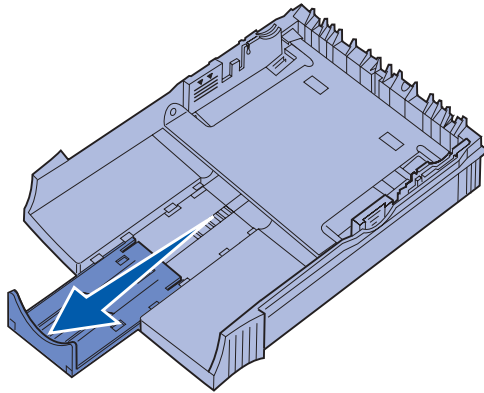

- 4 Flex the sheets back and forth to loosen them, fan the sheets on all four sides, and flex them again.
- 5 If loading letterhead paper, insert letterhead facedown with the top of the page entering the printer first.

*Load paper*

6 Make sure the paper is under both corner bucklers and lying flat in the tray.

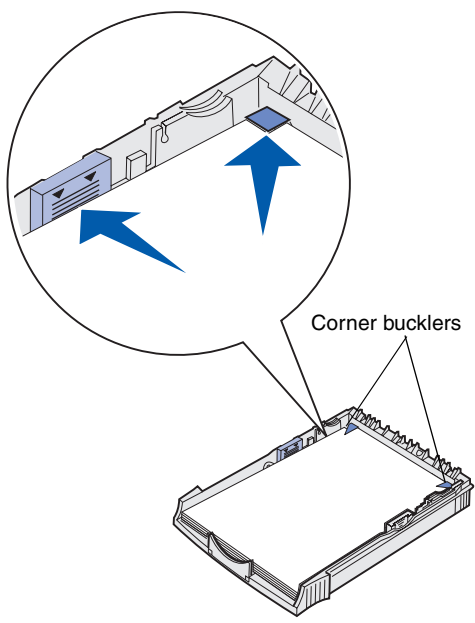

**Note:** When you load the tray, do not exceed the maximum stack height indicated by the label in the tray. Overfilling the tray may cause paper jams.

7 Slide the paper guides flush against the edges of the paper.

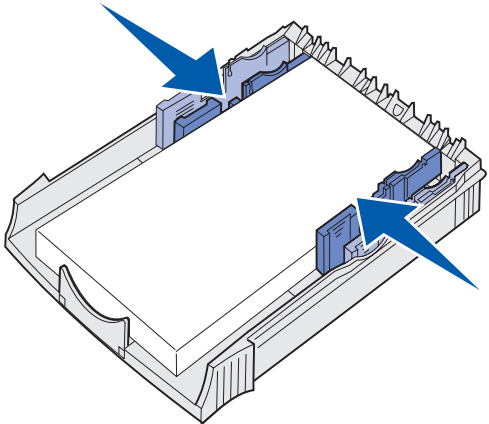

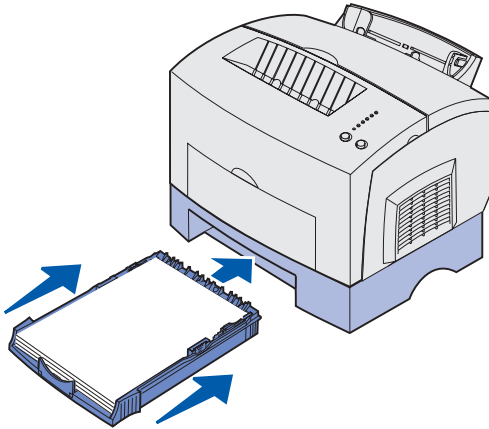

- 8** Reinstall the tray, making sure it is pushed all the way in.
- 9** Select the paper size and type from your software application.
- 10** Start your print job.

## Loading the manual feed

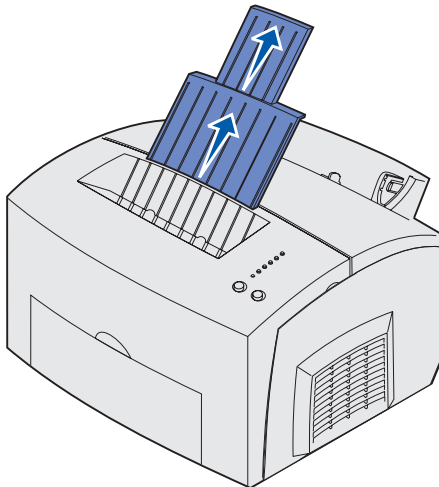

Use the manual feed to feed media, one sheet at a time, into your printer.

If you experience problems feeding envelopes or card stock in tray 1, try printing them one at a time from the manual feed.

- 1** Extend the front paper support on the top output bin until you hear a *click*.
- 2** If you are loading legal paper, extend the front paper support all the way up.
- 3** Open the front output door if you are printing on special media.
- 4** If loading:
  - letterhead paper, insert one sheet of letterhead with the top of the page pointing down, facing you
  - card stock, insert one card or sheet vertically

- envelopes, insert one envelope vertically, flap side down with the stamp area in the top left corner

To reduce paper jams, do not use envelopes that:

- Have excessive curl
- Are stuck together
- Are damaged in any way
- Contain windows, holes, perforations, cutouts, or embossing
- Use metal clasps, string ties, or metal folding bars
- Have postage stamps attached
- Have any exposed adhesive when the flap is in the sealed position

**5** Slide the paper guides flush against the edges of the paper or envelope.

**6** Select the paper size and type from your software application.

**7** Start your print job.

**8** Press and release **Continue** to start printing.

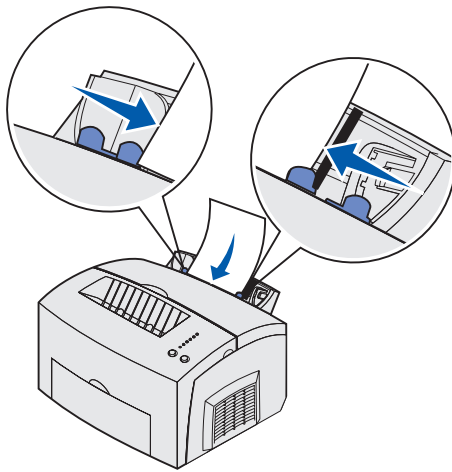

*Load paper*

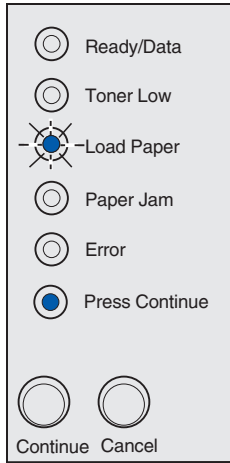

**9** When the Load Paper light and the Press Continue light come on, place another piece of media in the manual feed.

**10** Press and release **Continue** to print another page.

# Step 6: Attach cables

**CAUTION:** Do not connect or disconnect a communication port, a teleport, or any other connector during a lightning storm.

You can attach your printer locally using either a USB or parallel connection.

## USB cable

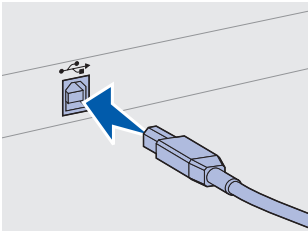

Be sure to match the USB symbol on the cable to the USB symbol on the printer.

A USB port is standard on most base models.

Windows 98 SE, Windows Me, Windows 2000, and Windows XP operating systems support USB connections. Some UNIX, Linux, and Macintosh computers also support USB connections. Refer to your computer operating system documentation to see if your system supports USB.

To attach the printer to a computer:

- 1** Connect the printer to the computer using a USB or parallel cable.

A USB port requires a USB cable such as Lexmark part number 12A2405 (2 m [6.5 ft]). Be sure to match the USB symbol on the cable to the USB symbol on the printer.

- 2** Plug one end of the printer power cord into the socket at the back of the printer and the other end into a properly grounded outlet.
- 3** Turn on your printer.

After the printer completes its internal tests, the **Ready** message indicates that the printer is ready to receive jobs.

If you see a message other than **Ready** on the display, refer to the publications CD for instructions on clearing the message. Click **Printing**, and then click **Understanding printer messages**.

- 4** Turn on your computer and any other peripherals.
- 5** Go to “Install drivers for local printing” on page 26.

## **Parallel cable**

A parallel port requires an IEEE-1284 compliant parallel cable such as Lexmark part number 1329605 (3 m [10 ft]) or 1427498 (6 m [20 ft]).



# Step 7: Install drivers for local printing

A local printer is a printer attached to your computer using a USB or parallel cable.

For Windows operating systems, you can use the hardware wizard and use the drivers CD to install your printer drivers. Launch the CD and follow the instructions to install printer software.

A printer driver is software that lets your computer communicate with your printer. The procedure to install drivers depends on the operating system you are using.

Select your operating system and cable from the table below for driver installation instructions.

Operating system	Cable	Go to page...
Windows XP	USB* or Parallel	<b>27</b>
Windows 2000	USB* or Parallel	<b>28</b>
Windows Me	USB* or Parallel	<b>28</b>
Windows 98	USB* or Parallel	<b>29</b>
Windows NT 4.x	Parallel only	<b>30</b>
Windows 95	Parallel only	<b>30</b>
Macintosh	USB only	<b>31</b>
UNIX/Linux	USB only	<b>32</b>

\*If you attach a USB printer cable while your printer and computer are turned on, the Windows hardware wizard launches immediately. Find the instructions for your operating system and use them to answer the plug and play screens.

# Windows

## *Before you install*

**Note:** Installing a custom driver will replace the system driver. A separate printer object will be created and appear in the Printers folder.

## *Using Windows XP with USB or parallel cable*

**Note:** Business versions of Windows XP require that you have administrative access to install printer drivers on your computer.

In addition to the following driver installation instructions, you may need to refer to the documentation that shipped with your computer and your Windows software.

Some versions of Windows software may already include a system printer driver, so installation is automatic in later versions of Windows. System drivers work well for simple print jobs, but they contain less functionality than our enhanced custom driver.

To obtain all the features of the custom driver, install the custom printer driver using the drivers CD that shipped with the printer.

Drivers are also available in downloadable software packages on Lexmark's Web site at [www.lexmark.com](http://www.lexmark.com).

When the Found New Hardware Wizard screen appears:

- 1** Insert the drivers CD. If the CD auto launches, exit the CD. Click **Next**.
- 2** Browse to the location of the printer driver on the drivers CD, and then click **Next**.  
  
D:\drivers\win\_2000\
- 3** Disregard the next two messages and click **Continue Anyway**. Your printer has been thoroughly tested and is compatible with Windows XP. The wizard copies all of the necessary files and installs the printer driver.
- 4** Click **Finish** when the software is installed.
- 5** Print a test page to verify printer setup:
  - a** Click **Start** ▶ **Settings** ▶ **Printers**.
  - b** Select the printer you just created.
  - c** Click **File** ▶ **Properties**.
  - d** Click **Print Test Page**. When a test page prints successfully, printer setup is complete.

## Using Windows 2000 with USB or parallel cable

**Note:** You need administrative access to install printer drivers on your computer.

## Using Windows Me with USB or parallel cable

**Note:** Depending on the software and printers already installed on your computer, your screens may vary from those in the instructions.

When the Found New Hardware Wizard screen appears:

- 1** Insert the drivers CD. If the CD auto launches, exit the CD. Click **Next**.
- 2** Select **Search for a suitable driver**, and then click **Next**.
- 3** Select *only* **Specify a location**, and then click **Next**.
- 4** Browse to the location of the printer driver on the drivers CD.  
  
D:\Drivers\Win\_2000\
- 5** Click **Open**, and then click **OK**.
- 6** Click **Next** to install the driver that is displayed. *Disregard the message that the driver is not digitally signed.*
- 7** Click **Finish** when the software is installed.
- 8** Print a test page to verify printer setup:
  - a** Click **Start** ▶ **Settings** ▶ **Printers**.
  - b** Select the printer you just created.
  - c** Click **File** ▶ **Properties**.
  - d** Click **Print Test Page**. When a test page prints successfully, printer setup is complete.

You must install both a USB port driver and an enhanced custom print driver.

When the Found New Hardware Wizard screen appears:

- 1** Insert the drivers CD. If the CD auto launches, exit the CD. Click **Next**.
- 2** Select **Automatic search for the best driver (recommended)**, and then click **Next**. The wizard searches for a USB port driver. The name of it will be similar to your printer name.
- 3** After the USB port driver is found, click **Finish**.
- 4** Select **Automatic search for the best driver (recommended)**, and then click **Next**. The wizard now searches for a printer driver.

- 5 Select your printer and driver from the list, and then click **OK**. Make sure you select the driver in the correct language you want to use.  
  
D:\Drivers\WIN\_9X\<LANGUAGE>
- 6 After the printer driver is installed, click **Finish**.
- 7 Use the default printer name or type a unique name for your printer, and then click **Next**.
- 8 Click **Yes (recommended)**, and then click **Finish** to print a test page.
- 9 After the test page prints, click **Yes** to close the window.
- 10 Click **Finish** to complete the installation and close the wizard. You are now ready to print.

## ***Using Windows 98 with a USB or parallel cable***

**Note:** Depending on the software and printers already installed on your computer, your screens may vary from those in the instructions.

You must install both a USB port driver and an enhanced custom print driver.

When the Add New Hardware Wizard screen appears:

- 1 Insert the drivers CD, and then click **Next**. If the CD auto launches, exit the CD.
- 2 Select **Search for the best driver for your device (recommended)**, and then click **Next**.
- 3 Select *only* **CD-ROM drive**, and then click **Next**.
- 4 After the wizard finds the USB port driver, click **Finish**.
- 5 Select **To install the updated driver (recommended)**, and then click **Next**.
- 6 Select **Specify a location** and browse to the location of the printer driver on the drivers CD, and then click **OK**.  
  
D:\Drivers\WIN\_9X\<language>
- 7 Select **To install the updated driver (recommended)**, and then click **Next**.
- 8 After the printer driver is installed, click **Finish**.
- 9 Use the default printer name or type a unique name for your printer, and then click **Next**.

*Install drivers for local printing*

- 10 Select **Yes** to print a test page, and then click **Finish**. All the necessary files are installed on your computer.
- 11 After the test page prints, click **Yes** to close the message window.
- 12 Click **Finish** to complete the installation. You are now ready to print.

## ***Using Windows NT with a parallel cable***

**Note:** USB support is not available for Windows NT operating systems.

**Note:** You need administrative access to install printer drivers on your computer.

## ***Using Windows 95 with a parallel cable***

**Note:** USB support is not available for Windows 95 operating systems.

The easiest way to install a driver is to use the drivers CD that shipped with your printer.

- 1 Insert the drivers CD. If the CD auto launches, exit the CD. Click **Next**.
- 2 Click **Install Printer Software**.
- 3 Click **Agree** to accept the license agreement.
- 4 Select **Local Printer**, and then click **Next**.
- 5 Make sure the correct printer and port are listed, and then click **OK**. You are now ready to print.

When the Update Device Driver Wizard screen appears:

- 1 Insert the drivers CD. If the CD auto launches, exit the CD.  
*If a system-compatible driver is found on your operating system, the Wizard installs it.*  
*If no compatible system driver is found on your operating system, click **Other Locations**.*
- 2 Browse to the location of the printer driver on the drivers CD, and then click **OK**.  
`D:\drivers\win_9x\english`
- 3 Click **Finish**. The Add Printer Wizard screen appears.
- 4 Use the default printer name or type a unique name for your printer, and then click **Next**.
- 5 Click **Yes** to print a test page.
- 6 Click **Finish**. A test page is sent to the printer once the driver files are copied to your computer. You are now ready to print.

*Install drivers for local printing*

# Macintosh

Macintosh OS 8.6 or later is required for USB printing. To print locally to a USB-attached printer you must create a desktop printer icon (Macintosh 8.6–9.x) or create a queue in Print Center (Macintosh OS X).

## ***Creating a desktop printer icon (Macintosh 8.6–9.x)***

**Note:** A PPD file provides detailed information about the capabilities of a printer to your Macintosh computer.

**Note:** A PPD for your printer is also available in a downloadable software package from Lexmark's Web site at [www.lexmark.com](http://www.lexmark.com).

- 1** Install a printer PostScript Printer Description (PPD) file on your computer.
  - a** Insert the drivers CD.
  - b** Double-click **Classic**, and then double-click the installer package for your printer.
  - c** Choose the language you want to use, and then click **OK**.
  - d** Click **Accept** after you read the license agreement.
  - e** Click **Continue** after you finish with the Readme file.
  - f** Choose a default paper size.
  - g** On the Easy Install screen, click **Install**. All the necessary files are installed on your computer.
  - h** Click **Quit** when installation is complete.
- 2** Do one of the following:
  - Macintosh 8.6-9.0:* Open **Apple LaserWriter**.
  - Macintosh 9.1-9.x:* Open **Applications**, and then **Utilities**.
- 3** Double-click **Desktop Printer Utility**.
- 4** Select **Printer (USB)**, and then click **OK**.
- 5** In the USB Printer Selection section, click **Change**.
  - If your printer does not appear in the USB Printer Selection list, make sure the USB cable is properly connected and the printer is turned on.*
- 6** Select the name of your printer, and then click **OK**. Your printer appears in the original Printer (USB) window.
- 7** In the PostScript Printer Description (PPD) File section, click **Auto Setup**. Make sure your printer PPD now matches your printer.
- 8** Click **Create**, and then click **Save**.

*Install drivers for local printing*

## Creating a queue in Print Center (Macintosh OS X)

**Note:** A PPD file provides detailed information about the capabilities of a printer to your Macintosh computer.

**Note:** A PPD for your printer is also available in a downloadable software package from Lexmark's Web site at [www.lexmark.com](http://www.lexmark.com).

## UNIX/Linux

**9** Specify a printer name, and then click **Save**. Your printer is now saved as a desktop printer.

**1** Install a printer PostScript Printer Description (PPD) file on your computer.

**a** Insert the drivers CD.

**b** Double-click **Mac OS X**, and then double-click the installer package for your printer.

**c** On the Authorization screen, choose **Click the lock to make changes**.

**d** Enter your password, and then click **OK**.

**e** Click **Continue** on the Welcome screen and again after you view the Readme file.

**f** Click **Agree** to accept the license agreement.

**g** Select a Destination, and then click **Continue**.

**h** On the Easy Install screen, click **Install**. All the necessary files are installed on your computer.

**i** Click **Close** when installation is complete.

**2** Open Finder, click **Applications**, and then click **Utilities**.

**3** Double-click **Print Center**.

**4** Do one of the following:

*If your USB-attached printer appears in the Printer List, you can quit Print Center. A queue has been created for your printer.*

*If your USB-attached printer does not appear in the Printer List, make sure the USB cable is properly connected and the printer is turned on. After the printer appears in the Printer List, you can quit Print Center.*

Your printer supports local printing on many UNIX and Linux platforms, such as Sun Solaris and Red Hat.

The Sun Solaris and Linux packages are available on the drivers CD and on the Lexmark Web site at [www.lexmark.com](http://www.lexmark.com). The *User's Guide*

*Install drivers for local printing*

in each package gives detailed instructions for installing and using Lexmark printers in UNIX and Linux environments.

All the printer driver packages support local printing using a parallel connection. The driver package for Sun Solaris supports USB connections to Sun Ray appliances and Sun workstations.

Visit the Lexmark Web site at **[www.lexmark.com](http://www.lexmark.com)** for a complete list of supported UNIX and Linux platforms.



# Step 8: Verify printer setup

## Turning on the printer

- 1 Plug one end of the printer cord into the power cord connector at the back of the printer and the other end into a properly grounded outlet.
- 2 Turn on the printer.

All indicator lights cycle (each light blinks, from top to bottom, and then cycles again).

## Printing a setup page

Print a menu settings page for a list of current printer settings:

- 1 Press and release **Continue** to print the page.
- 2 On the menu settings page:
  - Verify that the options you installed are correctly listed under “Installed Features.”  
If an option you installed is not listed on the menu settings page, turn the printer off, unplug the power cord, and reinstall the option.
  - Verify that the amount of memory installed is correctly listed under “Printer Information.” Verify that the paper trays are configured for the sizes and types of paper you loaded.

# Step 9: Distribute information to users



## Identifying printer users

Several types of users may need access to the information stored on the publications CD:

- Users sending print jobs
- Network printer administrators
- Help desk personnel
- Information technology support staff

## Locating helpful information

**Note:** The publications CD is shipped inside the *Setup Guide*.

Launch the publications CD and browse the contents to see a complete list of the available information. If you have a version of Acrobat capable of full text searching, we have created catalog entries to help you find the information you need.

The information provided on the publications CD includes:

- Tips for successful printing
- Ways to improve print quality
- Information about using the printer operator panel
- Instructions for replacing supplies
- Solutions to common printing problems
- Methods for clearing paper jams
- Overview of printer menus
- Explanation of printer messages

## Distributing the information

You can give users access to the information on the publications CD in several ways:

- Give the publications CD to a system administrator or the Help desk.
- Copy the entire contents of the CD (or just specific topics) to a shared network drive or intranet site.
- Each topic on the publications CD is a separate PDF. Launch the CD, click **Other resources**, and then click **File locations**.
- Send Lexmark's printer documentation URL to printer users ([www.lexmark.com/publications](http://www.lexmark.com/publications)). Users with Internet access can browse the site.
- Print the information on the publications CD and store it near the printer for easy access. For printing instructions, launch the CD and then click **Navigation**.

## Congratulations!

You are now ready to use your new printer. Save this book if you anticipate purchasing printer options in the future.

# Understanding the operator panel lights

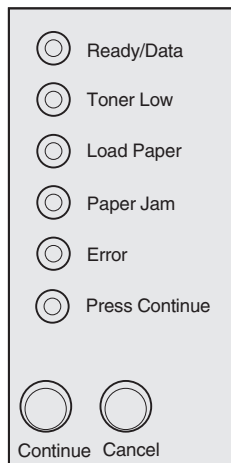

The operator panel lights mean different things, depending on their sequence. They indicate that the printer is ready to print, the printer needs intervention, or the printer needs servicing.

Some of the more common light sequences are shown in the next section. For a complete explanation of all of the light sequences, refer to the “Understanding the operator panel lights” section of the publications CD.

## Operator panel terms

Light is on



Light is off



Light is blinking



Light is blinking slowly

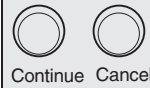

### Press **Continue**

- Press **Continue** briefly (approximately one second) to restart the printer.
- Press and release **Continue** twice quickly to display an error code.

### Press **Cancel**

- Press and release **Cancel** to cancel the job currently printing.
- Press and hold **Cancel** until all of the lights come on to reset the printer.

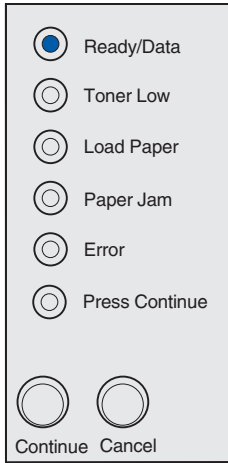

The printer is ready to receive and process data.

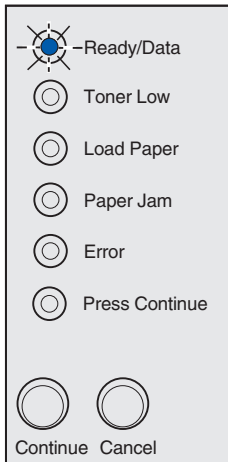

The printer is busy receiving or processing data.

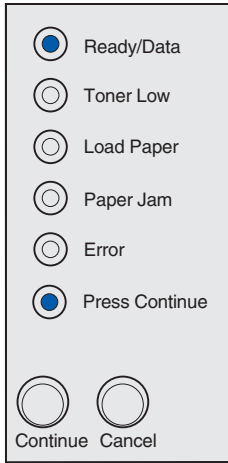

The printer is waiting until additional data is received.

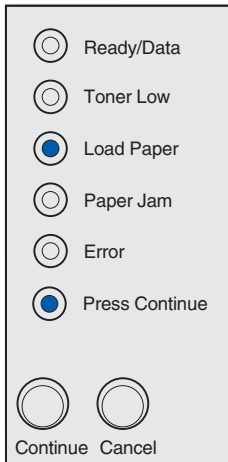

Tray 1 or the optional 250-sheet tray is out of media or the media did not feed properly.

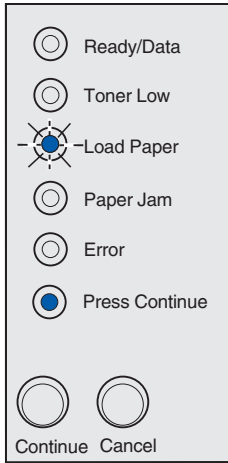

The printer prompts you to load another sheet of media in the manual feed.

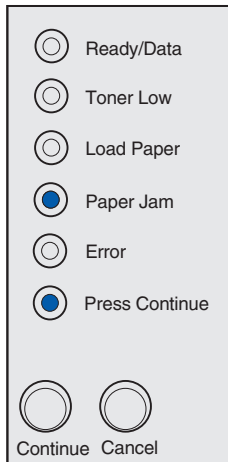

The printer detects a jam. Press and release **Continue** twice quickly to display the secondary paper jam light sequence.



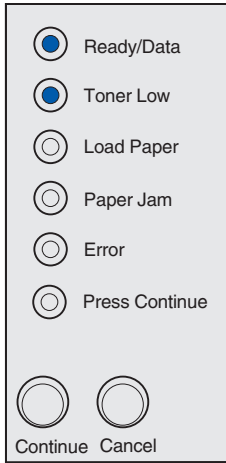

The printer alerts you that the toner is getting low. If you do not have a replacement cartridge, order one now.

To use the remaining toner, remove the print cartridge, gently shake it back and forth, and reinsert it. When the print fades or no longer prints satisfactorily, replace the print cartridge.

**Note:** On the Lexmark E220, the Toner Low light does not come on if the 1,500-page starter print cartridge is installed.

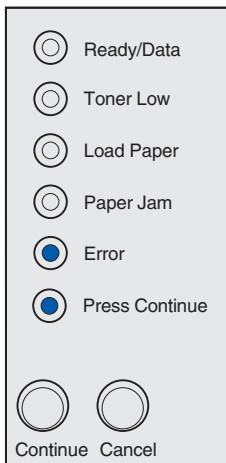

A secondary error has occurred:

- 1** Quickly press and release **Continue** twice to display the secondary error code light sequence.
- 2** Refer to the “Understanding the Operator Panel Lights” section in the publications CD for information on what the light sequence means and what you can do.

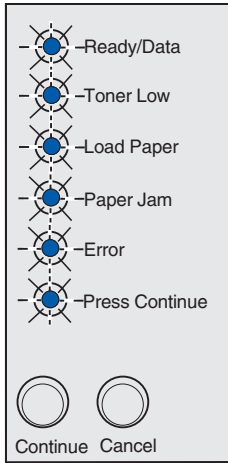

The printer has a service error. Turn the printer off and back on. If the lights are still blinking, contact your point of purchase.

# Troubleshooting tips

<b>Problem:</b>	<b>What to do:</b>
<b>Installing a print cartridge</b>	
Characters appear light or blurred.	<ul style="list-style-type: none"><li>• The print cartridge may be low on toner. Replace the cartridge.</li></ul>
The printer seems to be printing, but pages are blank.	<ul style="list-style-type: none"><li>• The print cartridge has an error. Replace the cartridge.</li></ul>
The printer is on, but nothing prints. Jobs are not printing and the Error light is on solid.	<ul style="list-style-type: none"><li>• Make sure the print cartridge is installed.</li></ul>
<b>Attaching cables</b>	
Unexpected characters print or characters are missing.	<ul style="list-style-type: none"><li>• Make sure the parallel cable or USB cable is firmly plugged in at the back of the printer.</li></ul>
The operator panel lights do not come on when the printer is turned on.	<ul style="list-style-type: none"><li>• Make sure the power cord is firmly plugged in at the back of the printer and at the electrical outlet.</li></ul>
<b>Loading paper</b>	
Toner smudges appear on the page.	<ul style="list-style-type: none"><li>• Make sure the paper is straight and unwrinkled.</li></ul>
The paper sticks together/printer feeds multiple sheets of paper.	<ul style="list-style-type: none"><li>• Remove the paper from tray 1 or optional 250-sheet tray and fan the paper.</li><li>• Do not overfill tray 1 or the optional 250-sheet tray.</li><li>• Make sure the paper is <i>under</i> both corner bucklers and lying flat in the optional 250-sheet tray.</li></ul>
The paper skews or buckles.	<ul style="list-style-type: none"><li>• Do not overfill tray 1 or the optional 250-sheet tray.</li><li>• Make sure the paper guides are properly positioned against the edges of the paper.</li></ul>

Problem:	What to do:
The paper fails to feed from tray 1.	<ul style="list-style-type: none"> <li>• Make sure tray 1 is selected from the printer driver.</li> <li>• Remove the paper from tray 1 and fan the paper.</li> </ul>
The paper fails to feed from the optional 250-sheet tray.	<ul style="list-style-type: none"> <li>• Make sure optional 250-sheet tray is selected from the printer driver.</li> <li>• Make sure the tray is pushed all the way in.</li> <li>• Make sure the metal plate is pressed down.</li> <li>• Make sure the paper is under both corner bucklers.</li> <li>• Make sure the paper does not exceed the stack height indicator.</li> <li>• Remove the paper from the optional 250-sheet tray, and then fan the paper.</li> </ul>

# Statement of Limited Warranty

## Lexmark International, Inc., Lexington, KY

This warranty applies to the United States and Canada. For customers outside the U.S. and Canada, refer to the country-specific warranty information that came with your printer.

## Lexmark E220

This Statement of Limited Warranty applies to this product if it was originally purchased for your use, and not for resale, from Lexmark or a Lexmark remarketer, referred to in this statement as "Remarketer."

## Warranty

Lexmark warrants that this product:

- Is manufactured from new parts, or new and serviceable used parts, which perform like new parts
- Is free from defects in material and workmanship
- Conforms to Lexmark's official published specifications
- Is in good working order

If this product does not function as warranted during the warranty period, contact a Remarketer or Lexmark for repair without charge.

If this product is a feature or option, this statement applies only when that feature or option is used with the product for which it was designed. To obtain warranty service, you may be required to present the feature or option with the product.

If you transfer this product to another user, warranty service under the terms of this statement

is available to that user for the remainder of the warranty period. You should transfer proof of original purchase and this statement to that user.

## Warranty service

The warranty period is 12 months and starts on the date of original purchase as shown on the purchase receipt.

To obtain warranty service you may be required to present proof of original purchase. Warranty service will be provided

When warranty service involves the exchange of a product or part, the item replaced becomes the property of the Remarketer or Lexmark. The replacement may be a new or repaired item. The replacement item assumes the remaining warranty period of the original product.

Replacement is not available to you if the product you present for exchange is defaced, altered, in need of a repair not included in warranty service, or damaged beyond repair. Also, such product must be free of any legal obligation or restrictions that prevent its exchange.

Before you present this product for warranty service, remove all programs, data, and removable storage media.

For further explanation of your warranty alternatives and the nearest Lexmark authorized servicer in your area, please contact Lexmark at 1-859-232-3000, or on the World Wide Web at <http://support.lexmark.com>.

Remote technical support is provided for this product throughout its warranty period. Lexmark

offers a variety of extended warranty programs that include an extension of technical support. For products no longer covered by a Lexmark warranty, technical support may only be available for a fee.

### Extent of warranty

We do not warrant uninterrupted or error-free operation of a product.

Warranty service does not include repair of failures caused by:

- Modification or attachments
- Accidents or misuse
- Unsuitable physical or operating environment
- Maintenance by anyone other than Lexmark or a Lexmark authorized servicer
- Operation of a product beyond the limit of its duty cycle
- Failure to have installed a maintenance kit as specified (if applicable)
- Use of printing media outside of Lexmark specifications
- Use of other than Lexmark supplies (such as toner cartridges, inkjet cartridges, and ribbons)
- Use of other than Lexmark product or component

**ALL EXPRESS AND IMPLIED WARRANTIES, INCLUDING THE IMPLIED WARRANTIES OF MERCHANTABILITY AND FITNESS FOR A PARTICULAR PURPOSE, ARE LIMITED IN DURATION TO THE WARRANTY PERIOD. NO WARRANTIES, EXPRESS OR IMPLIED, WILL APPLY AFTER THIS PERIOD.**

### Limitation of liability

Your sole remedy under this Statement of Limited Warranty is set forth in this section. For any claim concerning performance or nonperformance of Lexmark or a Remarketer for this product under this Statement of Limited Warranty, you may

recover actual damages up to the limit set forth in the following paragraph.

Lexmark's liability for actual damages from any cause whatsoever will be limited to the greater of 1) \$5,000 or 2) the amount you paid for the product that caused the damages. This limitation of liability will not apply to claims by you for bodily injury or damage to real property or tangible personal property for which Lexmark is legally liable. In no event will Lexmark be liable for any lost profits, lost savings, incidental damage, or other economic consequential damages. This is true even if you advise Lexmark or a Remarketer of the possibility of such damages. Lexmark is not liable for any claim by you based on a third party claim.

This limitation of remedies also applies to any developer of materials supplied to Lexmark. Lexmark's and the developer's limitations of remedies are not cumulative. Such developer is an intended beneficiary of this limitation.

### Additional rights

Some states do not allow limitations on how long an implied warranty lasts, or do not allow the exclusion or limitation of incidental or consequential damages. If such laws apply, the limitations or exclusions contained in this statement may not apply to you.

This warranty gives you specific legal rights. You may also have other rights which vary from state to state.

**This is a placeholder for the inside back cover.**



P/N 21S0260  
E.C. 1SP004a

Lexmark and Lexmark with diamond design are trademarks of Lexmark International, Inc., registered in the United States and/or other countries.

© 2003 Lexmark International, Inc.

740 West New Circle Road  
Lexington, Kentucky 40550