



# Z700 Series Color Jetprinter™ P700 Series Photo Jetprinter™

---

## User's Guide for Mac OS X

- **Setup troubleshooting**

*A checklist to find solutions to common setup problems.*

- **Printer overview**

*Learn about the printer parts and the printer software.*

- **Printing ideas**

*How to print several projects on various types of paper.*

- **Maintenance**

*Caring for your cartridges and ordering supplies.*

- **General troubleshooting**

*Error messages, print quality problems, paper jams, and much more.*

January 2003

## **Edition: January 2003**

**The following paragraph does not apply to any country where such provisions are inconsistent with local law:** LEXMARK INTERNATIONAL, INC., PROVIDES THIS PUBLICATION "AS IS" WITHOUT WARRANTY OF ANY KIND, EITHER EXPRESS OR IMPLIED, INCLUDING, BUT NOT LIMITED TO, THE IMPLIED WARRANTIES OF MERCHANTABILITY OR FITNESS FOR A PARTICULAR PURPOSE. Some states do not allow disclaimer of express or implied warranties in certain transactions; therefore, this statement may not apply to you.

This publication could include technical inaccuracies or typographical errors. Changes are periodically made to the information herein; these changes will be incorporated in later editions. Improvements or changes in the products or the programs described may be made at any time.

Comments about this publication may be addressed to Lexmark International, Inc., Department F95/032-2, 740 West New Circle Road, Lexington, Kentucky 40550, U.S.A. In the United Kingdom and Eire, send to Lexmark International Ltd., Marketing and Services Department, Westhorpe House, Westhorpe, Marlow Bucks SL7 3RQ. Lexmark may use or distribute any of the information you supply in any way it believes appropriate without incurring any obligation to you. You can purchase additional copies of publications related to this product by calling 1-800-553-9727. In the United Kingdom and Eire, call +44 (0)8704 440 044. In other countries, contact your point of purchase.

References in this publication to products, programs, or services do not imply that the manufacturer intends to make these available in all countries in which it operates. Any reference to a product, program, or service is not intended to state or imply that only that product, program, or service may be used. Any functionally equivalent product, program, or service that does not infringe any existing intellectual property right may be used instead. Evaluation and verification of operation in conjunction with other products, programs, or services, except those expressly designated by the manufacturer, are the user's responsibility.

Lexmark and Lexmark with diamond design are trademarks of Lexmark International, Inc., registered in the United States and/or other countries. Color Jetprinter and Photo Jetprinter are trademarks of Lexmark International, Inc. Other trademarks are the property of their respective owners.

© 2003 Lexmark International, Inc.

**All rights reserved.**

### **UNITED STATES GOVERNMENT RIGHTS**

This software and any accompanying documentation provided under this agreement are commercial computer software and documentation developed exclusively at private expense.

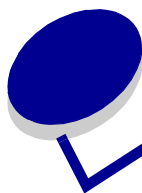

# Contents

---

<b>Chapter 1: Printer overview .....</b>	<b>5</b>
Understanding the printer parts.....	5
Using memory cards (Lexmark P700 Series only) .....	7
Using the printer software .....	9
Using the paper type sensor .....	14
<b>Chapter 2: Printing ideas.....</b>	<b>15</b>
Printing on plain paper .....	15
Printing photos .....	16
Printing on premium paper.....	18
Printing cards .....	20
Printing envelopes.....	23
Printing color images in black and white .....	25
Printing labels.....	26
Printing handouts .....	29
Printing iron-on transfers .....	31
Printing transparencies.....	33
Printing your document in reverse order .....	35
<b>Chapter 3: Maintenance.....</b>	<b>37</b>
Replacing the print cartridges.....	37
Specifying cartridge settings in the printer software.....	40
Aligning the print cartridges.....	41
Improving print quality .....	42
Preserving the print cartridges .....	44
Ordering supplies .....	44
<b>Chapter 4: Setup troubleshooting .....</b>	<b>45</b>

Troubleshooting checklist.....	45
When I insert the printer software CD, nothing happens.....	46
Solving printer software installation problems .....	47
<b>Chapter 5: General troubleshooting.....</b>	<b>49</b>
Solving network printing problems .....	49
Understanding error messages and flashing lights .....	49
Resolving unsuccessful or slow printing.....	51
Clearing paper misfeeds or jams.....	53
Solving print quality problems .....	55
Solving specialty media problems .....	57
<b>Notices .....</b>	<b>59</b>
<b>Glossary.....</b>	<b>61</b>
<b>Index.....</b>	<b>64</b>

# 1

## Printer overview

---

### *Understanding the printer parts*

### *Lexmark™ Z700 Series Color Jetprinter™*

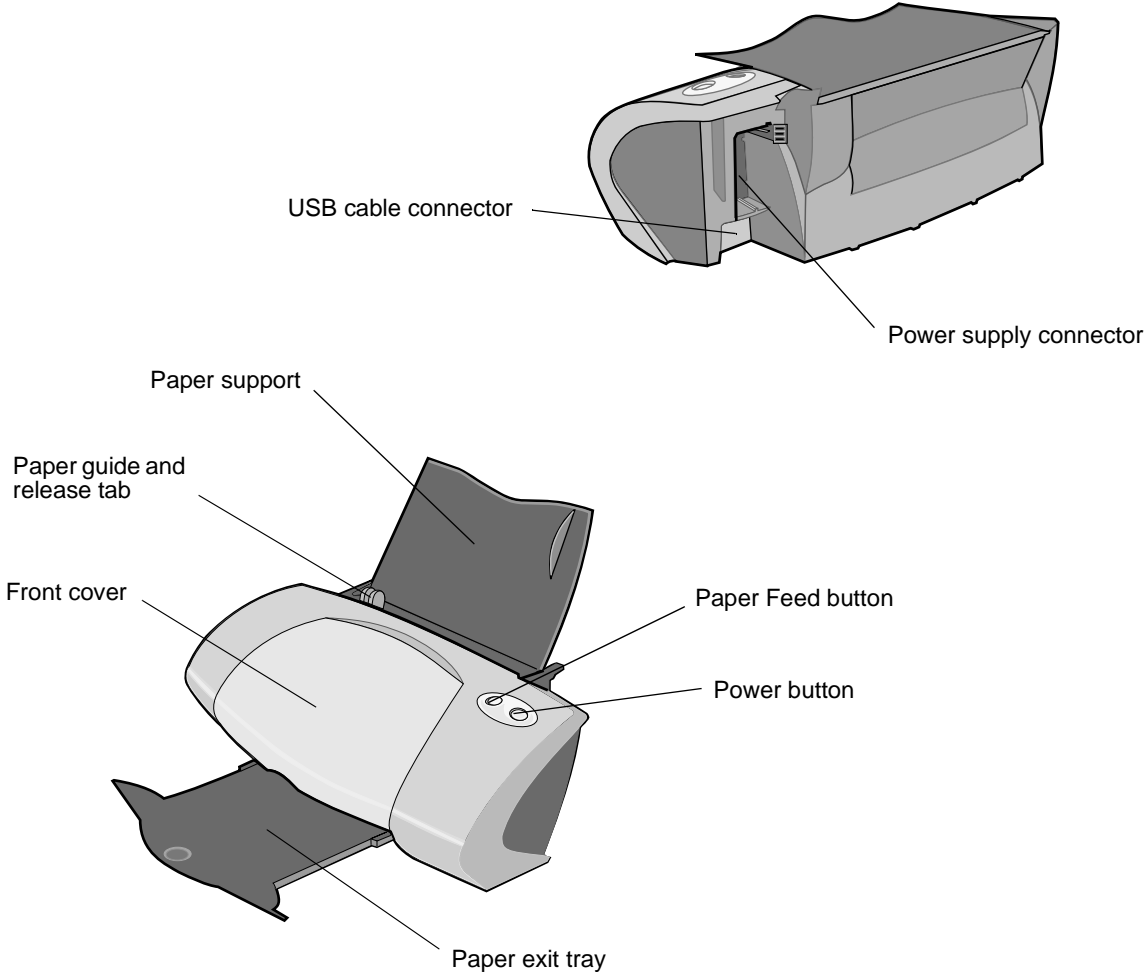

# Lexmark P700 Series Photo Jetprinter™

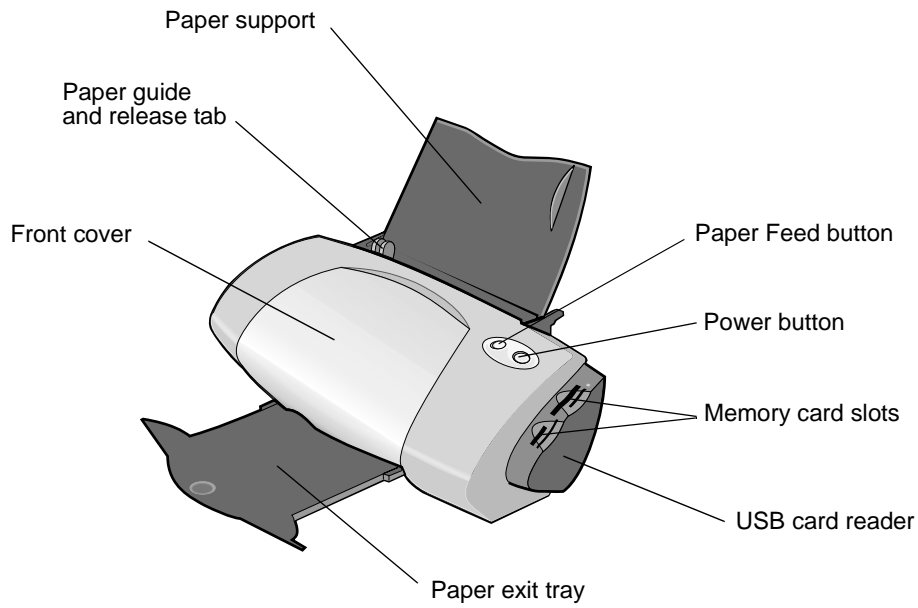
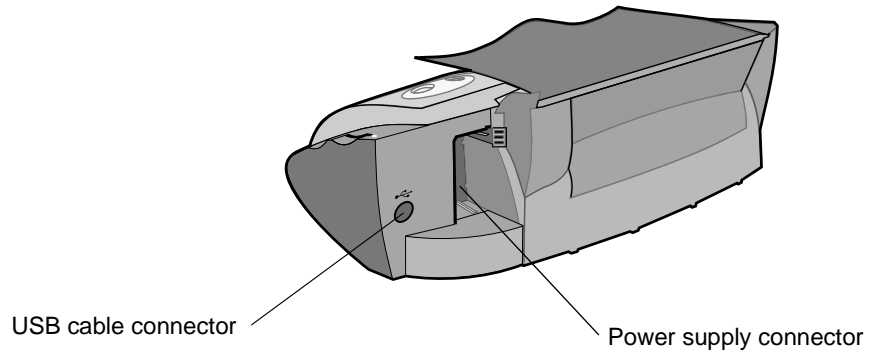

Use this:	When you want to:
Front cover	<ul style="list-style-type: none"> <li>• Install or change print cartridges.</li> <li>• Clear a paper jam.</li> </ul>
Memory card slots	Access your photos.
Paper exit tray	Stack paper after printing.

Use this:	When you want to:
Paper Feed button	<ul style="list-style-type: none"> <li>• Eject paper from the printer.</li> <li>• Check the printer status. For more information, see “Understanding error messages and flashing lights” on page 49.</li> </ul>
Paper guide and release tab	Make sure paper feeds correctly into the printer.
Paper support	Keep paper straight in the printer.
Power button	<ul style="list-style-type: none"> <li>• Turn the printer on or off.</li> <li>• Check the printer status. For more information, see “Understanding error messages and flashing lights” on page 49.</li> </ul>
Power supply connector	Supply power to the printer.
USB cable connector	Connect the printer to the computer.
USB card reader	Transfer data from a memory card to your computer.

## ***Using memory cards (Lexmark P700 Series only)***

Most digital cameras use a memory card to store photos. You can insert the memory card into your printer and print your photos or save them on your computer.

### ***Inserting a memory card***

Your printer supports the following digital media:

- CompactFlash I and II
- IBM Microdrive
- Secure Digital
- MultiMedia Card
- Memory Stick
- SmartMedia

The USB card reader on your printer has four slots to accommodate these media. This illustration shows you where to insert each of the supported memory cards.

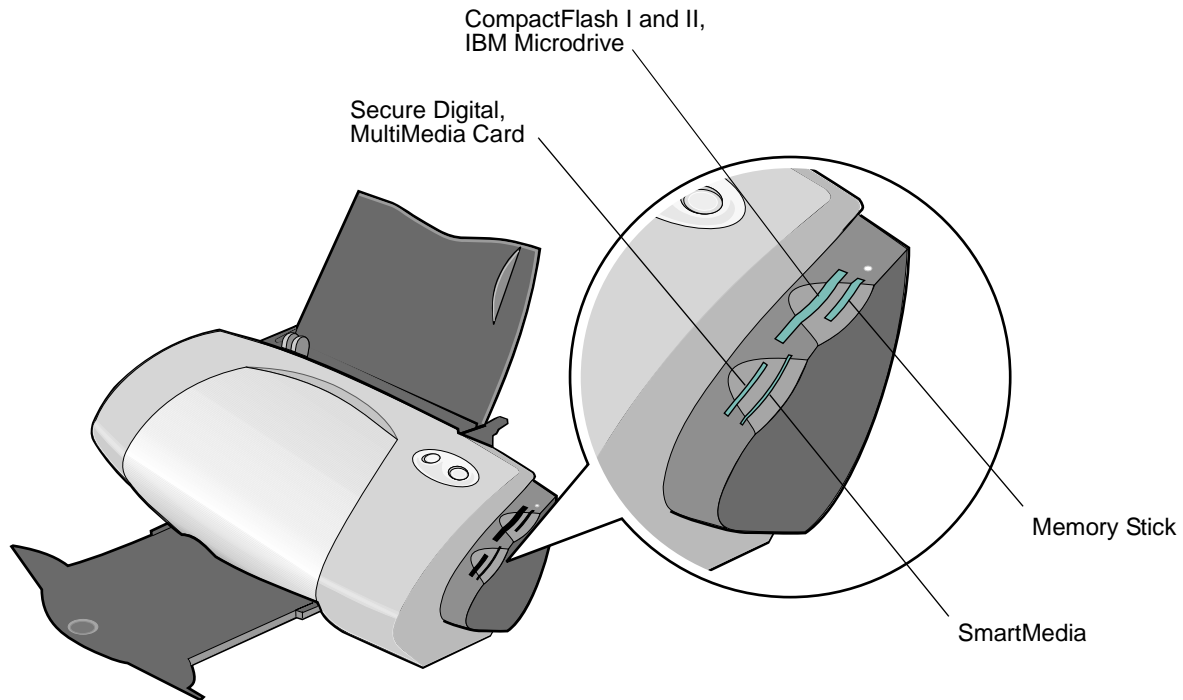

Before you insert your memory card, consider the following information:

- Your printer recognizes one source for photos at a time. Insert only one memory card at a time.
- A small button on top of the card reader lights up once the card is properly installed.

If you are inserting a memory card of this type:	Make sure:
<ul style="list-style-type: none"> <li>• CompactFlash I and II</li> <li>• IBM Microdrive</li> </ul>	The name label faces toward the printer.
<ul style="list-style-type: none"> <li>• Memory Stick</li> <li>• Secure Digital</li> <li>• MultiMedia Card</li> </ul>	The gold contact area faces away from the printer.
<ul style="list-style-type: none"> <li>• SmartMedia</li> </ul>	The gold contact area faces toward the printer.

When you insert your memory card into the card reader, an icon representing a new drive appears on your desktop. Once that new drive appears, you can work with the files in the same way as you would with any removable media like a floppy disk. When you are done with the memory card, drag the icon to the trash can. You can then remove the memory card.



## Using the printer software

Your printer integrates with the Page Setup dialog and Print dialog that come with Mac OS X. The CD that comes with your printer also includes the Z700-P700 Series Utility.

To customize the settings for your document, refer to the “Page Setup dialog” on page 9 and the “Print dialog” on page 10. For more information on which settings to select for your document, see “Printing ideas” on page 15. When you install the printer software, the Page Setup and Print dialogs are set to these default settings:

Print Quality: Normal

Paper Type: Automatic

Paper Size: A4 or U.S. Letter

Orientation: Portrait

**Note:** Your printer has a paper type sensing capability that automatically detects most paper types. For more information, see “Using the paper type sensor” on page 14.

### Page Setup dialog

While the document you want to print is open, use the Page Setup dialog to select settings such as paper size. To customize the settings in the Page Setup dialog:

- 1 From the software program, choose **File** ▶ **Page Setup**.

A screen similar to the following appears.

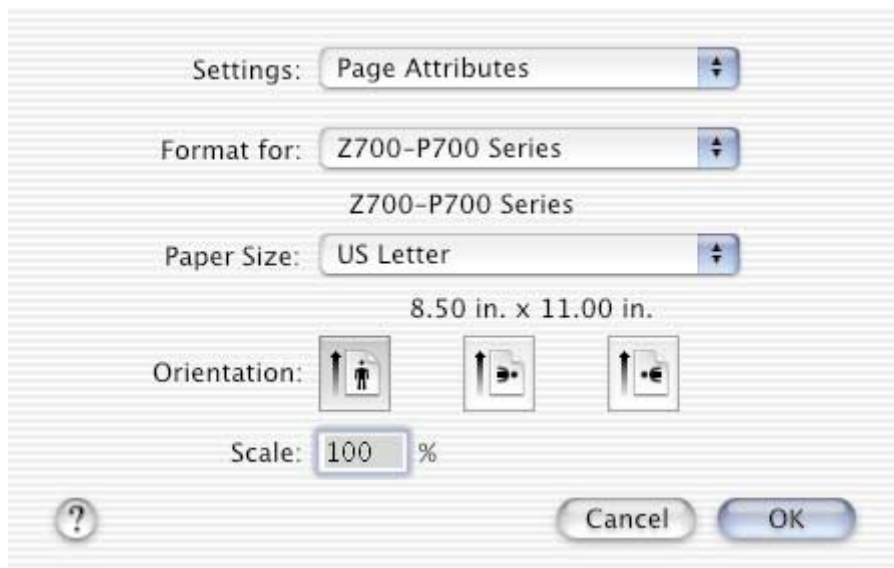

2 Change the settings as needed.

From:	Select:	When you want to:
Settings	Page Attributes	Choose a paper size, orientation, or scaling value for your document.
	Summary	View a summary of the current page settings.
Format for	Z700-P700 Series	Format your page for printing with your Z700-P700 Series printer.
Paper Size		Choose a paper size.
Orientation		Choose between portrait, landscape, or reverse landscape orientation.
Scale		Change the scaling value of your document. Valid values are from 1 - 100,000. Recommended values are between 25% and 400% of the original document size.

3 For more information about these settings, click ? to view the Mac OS X Help.

4 Click **OK** to apply the settings and close the Page Setup dialog.

## Print dialog

While your document is open, you can use the Print dialog to select settings that affect the appearance of your document. To customize the settings in the Print dialog:

1 From the software program, choose **File** ▶ **Print**.

A screen similar to the following appears.

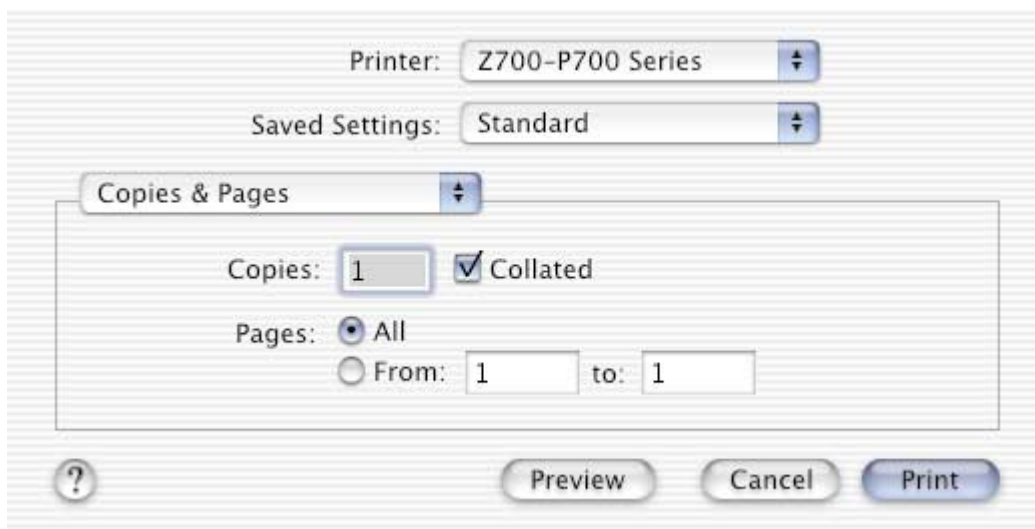

- 2 From the Printer pop-up menu, choose **Z700-P700 Series**.
- 3 Change the settings as needed.

From the pop-up menu, choose:	Select:	When you want to:
Copies & Pages	Copies	Specify the number of copies you want to print (1-999).
	Collated	Sort multiple copy jobs.
	Pages	Print all of the pages in a document or print a range of pages.
Layout	Pages per Sheet	Print multiple pages of your document on a single sheet of paper.
	Layout Direction	Print the pages of your document in a specified order.
	Border	Print a border around each page of your document.
Output Options	Save as File	Print your document to a PDF format.
Color Options	Document Color	Choose a color setting.
Advanced Layout	Print Last Page First	Print your document in reverse page order.
	Mirror	Print your document as a mirror image.
Quality & Media	Paper Type	Choose the paper type for your document.
	Print Quality	Choose a print quality. You can choose from <b>Quick Print</b> , <b>Normal</b> , <b>Better</b> , or <b>Best</b> . <b>Note:</b> Normal print quality is recommended for most documents. Higher print quality settings result in better quality documents for some paper types, but take longer to print. For more information about the appropriate print quality for your document, see "Printing ideas" on page 15.
Printer Services	Z700-P700 Series Utility	Get a direct link to the printer utility.
	Troubleshooting	Get a direct link to the Help Center.
	Order Supplies	Get a direct link to the Lexmark Web site.
	Software Version	View software version on installed files.
Summary		View a summary of the current print settings.
Save Custom Setting		Save the current print settings for future use.

- 4 If you want more information about the settings in the Print dialog, click ? to view Help on these items. When you are finished, click the red close button.
- 5 Click **Print** to apply your settings and print your document.

## ***Z700-P700 Series Utility***

Use the Z700-P700 Series Utility to monitor your printer and printer supplies. You can:

- Install cartridges
- Align cartridges
- Clean print nozzles
- Select a printer
- Calibrate the paper type sensor
- Print a test page
- Obtain information on ordering supplies
- Obtain software version information
- Configure a network printer
- Check for offers (United States and Canada only)

### **Using the Z700-P700 Series Utility**

- 1 From your desktop, double-click the **Z700-P700 Series Printer** folder. If the folder is not on your desktop, relaunch the printer software CD.

The Z700-P700 Series Printer dialog appears.

**2** Double-click **Z700-P700 Series Utility**.

**Note:** You can also access the Z700-P700 Series Utility from Printer Services in the Print dialog menu.

The Z700-P700 Series Utility appears.

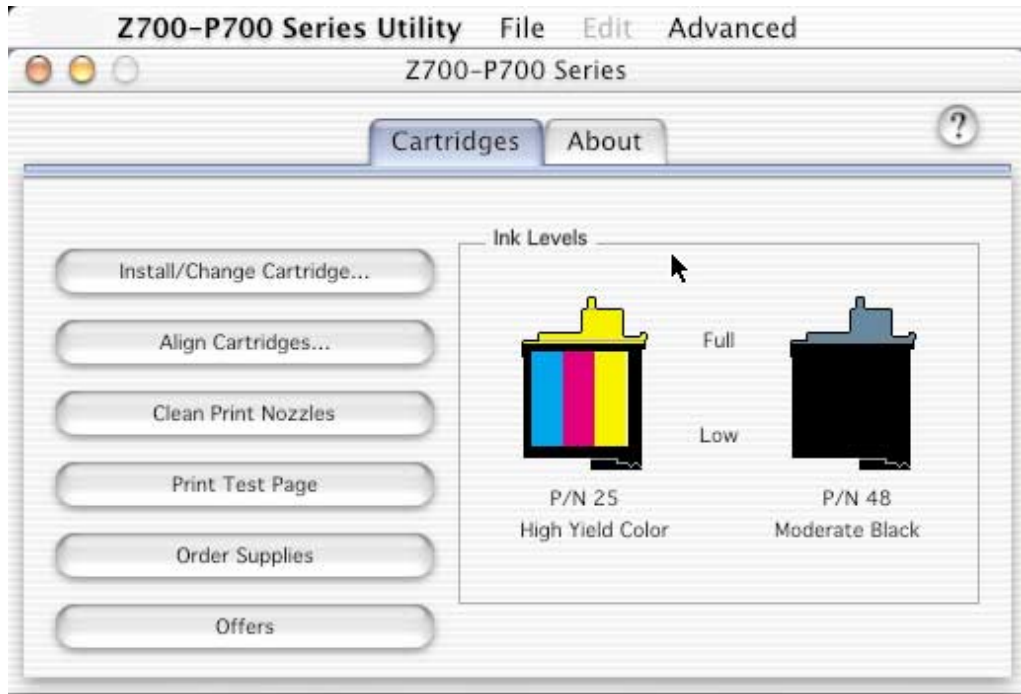

Click the:	Select:	When you want to:
Cartridges tab	Install/Change Cartridge	Specify cartridge settings in the printer software when installing or changing a cartridge. For more information, see “Replacing the print cartridges” on page 37.
	Align Cartridges	Align the cartridges. For more information, see “Aligning the print cartridges” on page 41.
	Clean Print Nozzles	Improve print quality by cleaning clogged print nozzles. For more information, see “Improving print quality” on page 42.
	Print Test Page	Verify if your printer is functioning properly.
	Order Supplies	Order supplies, such as print cartridges, from the Lexmark Web site. For more information, see “Ordering supplies” on page 44.
	Offers	Access the Lexmark Web site for offers. <b>Note:</b> United States and Canada only.
About tab		Obtain printer software version information.

Click the:	Select:	When you want to:
Advanced menu	Select Printer	<ul style="list-style-type: none"> <li>• Select a printer and make it the default printer.</li> <li>• Find the IP address for the selected printer.</li> <li>• Add a printer located on a remote subnet. You can add a single printer or search the subnet for all available printers.</li> <li>• View a list of all USB, USB print sharing, and network printers.</li> </ul>
	Network Printer Configuration	<ul style="list-style-type: none"> <li>• Configure a network printer.</li> <li>• View a list of network printers.</li> </ul>
	Calibrate Paper Type Sensor	Ensure that the paper type sensor is working correctly.

- 3 To learn more about what you can do with your printer, click ? to view the printer software Help.
- 4 Click the red button in the upper left corner to close the **Z700-P700 Series Utility**.

## *Using the paper type sensor*

Your printer has a paper type sensor that detects the following paper types loaded in your printer, and automatically adjusts the Paper Type setting in the Print dialog accordingly:

- Plain
- Coated
- Glossy/Photo
- Transparency

When you install your printer, the paper type sensor is set on Automatic (default).

If you want to turn off the paper type sensor and manually choose your paper type:

- 1 From the software program, choose **File ▶ Print**.
- 2 From the Printer pop-up menu, choose **Z700-P700 Series**.
- 3 From the pop-up menu in the upper left corner, choose **Quality & Media**.
- 4 From the Paper Type pop-up menu, choose your preferred paper type.
- 5 Click **Print**.

**Note:** Although the printer can detect the type of paper you are using, it cannot detect the paper size. Make sure you select the appropriate paper size in the Page Setup dialog.

## 2

# Printing ideas

---

## *Printing on plain paper*

You can print up to 100 sheets of paper at a time, depending on the thickness of the paper.

### *Step 1: Load the paper*

- Load the paper vertically against the right side of the paper support.

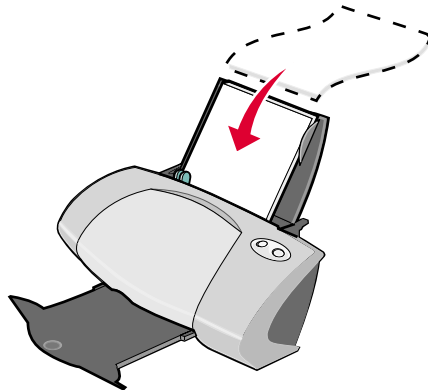

- Do not force the paper into the printer.
- Squeeze and slide the paper guide to the left edge of the paper.

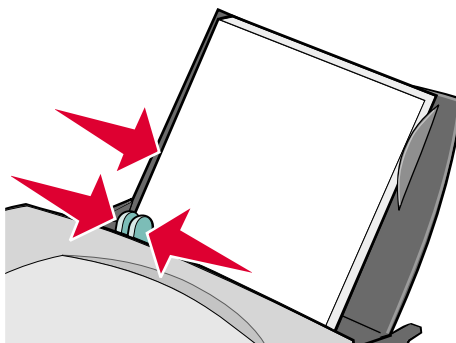

**Note:** If you are using Letter size paper, adjusting the paper guide may not be necessary.

## ***Step 2: Customize the print settings***

If you are using A4 or Letter size paper and you want to print with Normal print quality, you do not need to adjust the settings.

If you are using specialty media, customize the settings by following the steps for your paper type.

## ***Step 3: Print your document***

- 1 From the software program, choose **File ▶ Print**.
- 2 Click **Print**.

**Note:** The paper exit tray holds up to 50 sheets of paper. To print more than 50 pages, remove the first 50 sheets, and then continue printing.

## ***Printing photos***

You can load up to 50 sheets of photo or glossy paper, depending on the thickness of the paper. You may want to print your photos on plain paper before loading photo paper and changing your settings. This ensures that you do not waste photo paper perfecting the image you want to print.

To print on photo cards, see “Printing cards” on page 20.

### ***Step 1: Load the photo paper***

- For best results, use photo paper designed for inkjet printers.
- If your photo paper includes instructions, read them carefully.
- Load the paper against the right side of the paper support.

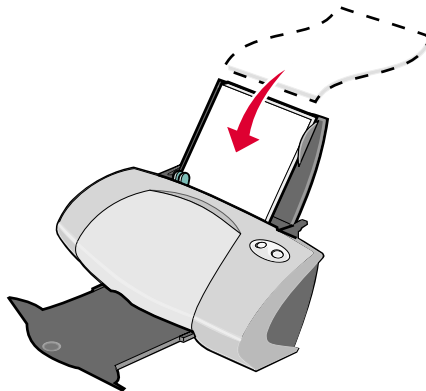



- Make sure your paper is not used or damaged.
- Make sure the glossy side is facing you.
- Do not force the paper into the printer.
- Squeeze and slide the paper guide to the left edge of the paper.

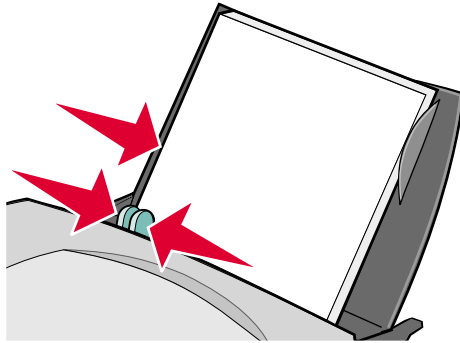

**Note:** If you are using Letter size photo paper, adjusting the paper guide may not be necessary.

## **Step 2: Customize the print settings**

- 1 Choose a paper size and orientation:
  - a From the software program, choose **File ▶ Page Setup**.
  - b From the Format for pop-up menu, choose **Z700-P700 Series**.
  - c From the Settings pop-up menu, choose **Page Attributes**.
  - d From the Paper Size pop-up menu, choose a paper size. To print borderless photos, choose one of the following paper sizes for borderless printing:
    - **U.S. Letter (Borderless)**
    - **A4 (Borderless)**
    - **U.S. 4 x 6 Photo (Borderless)**
  - e From Orientation, click the portrait, landscape, or reverse landscape icon.
  - f Click **OK**.
- 2 Choose a paper type and print quality:
  - a From the software program, choose **File ▶ Print**.
  - b From the Printer pop-up menu, choose **Z700-P700 Series**.

- c From the pop-up menu in the upper left corner, choose **Quality & Media**.

**Note:** If Automatic is not chosen in the Paper Type pop-up menu, choose **Glossy/Photo**.  
For more information, see “Using the paper type sensor” on page 14.

- d From Print Quality, click **Better** or **Best**.

**Note:** Higher print quality settings result in better quality documents, but may take longer to print.

### 3 To print borderless photos:

- a Make sure you choose one of the supported paper sizes for borderless printing from Paper Size in the Page Setup dialog.
- b From the software program, set the margins to zero.

**Note:** Disregard this step if your program does not support margin setting.

- c On the screen, make sure that the image covers the entire page.

## ***Step 3: Print your photos***

- 1 From the software program, choose **File ▶ Print**.
- 2 Click **Print**.

**Note:** To prevent smearing, remove each photo as it exits the printer, and then let it dry before stacking.

## ***Printing on premium paper***

You can load up to 100 pages of premium or coated paper, depending on the thickness of the paper.

### ***Step 1: Load the premium paper***

- If your paper includes instructions, read them carefully.

- Load the paper vertically against the right side of the paper support.

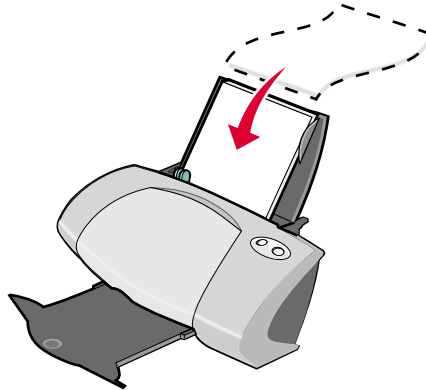

- Make sure your paper is not used or damaged.
- Make sure the print side is facing you.
- Do not force the paper into the printer.
- Squeeze and slide the paper guide to the left edge of the paper.

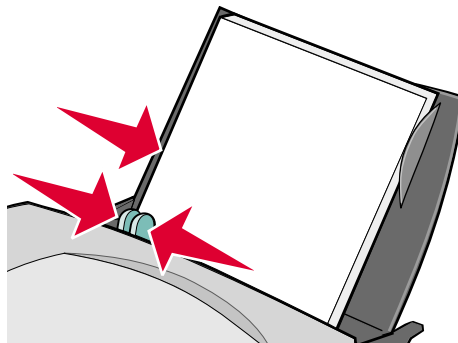

**Note:** If you are using Letter size paper, adjusting the paper guide may not be necessary.

## **Step 2: Customize the print settings**

- 1 Choose a paper size and orientation:
  - a From the software program, choose **File ▶ Page Setup**.
  - b From the Format for pop-up menu, choose **Z700-P700 Series**.
  - c From the Settings pop-up menu, choose **Page Attributes**.

- d From the Paper Size pop-up menu, choose a paper size.
- e From Orientation, click the portrait, landscape, or reverse landscape icon.
- f Click **OK**.

**2** Choose a paper type and print quality:

- a From the software program, choose **File ▶ Print**.
- b From the Printer pop-up menu, choose **Z700-P700 Series**.
- c From the pop-up menu in the upper left corner, choose **Quality & Media**.

**Note:** If Automatic is not chosen in the Paper Type pop-up menu, choose **Coated**. For more information, see “Using the paper type sensor” on page 14.

- d From Print Quality, select your preferred print quality. Normal is the default.

**Note:** Higher print quality settings result in better quality documents, but may take longer to print.

### ***Step 3: Print your document***

Click **Print**.

**Note:** The paper exit tray holds up to 50 sheets of paper. To print more than 50 pages, remove the first 50 sheets, and then continue printing.

## ***Printing cards***

You can load up to 25 greeting cards, index cards, photo cards, or postcards into the paper support, depending on the thickness of the cards.

### ***Step 1: Load the cards***

- If your cards include instructions, read them carefully.

- Load the cards vertically against the right side of the paper support.

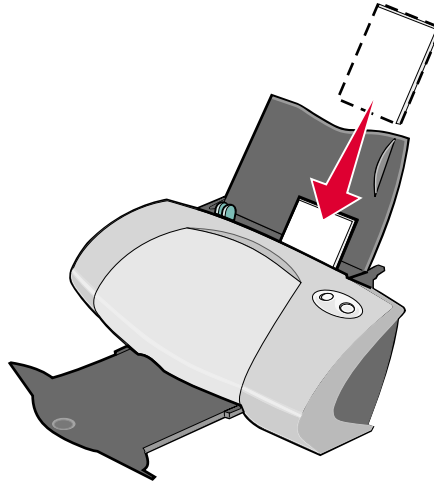

- Make sure your cards are not used or damaged.
- Make sure the print side is facing you.
- Do not force the cards into the printer.
- Squeeze and slide the paper guide to the left edge of the cards.

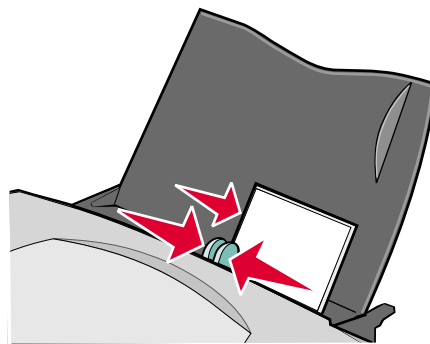

## **Step 2: Customize the print settings**

- 1 Choose a paper size and orientation:
  - a From the software program, choose **File ▶ Page Setup**.
  - b From the Format for pop-up menu, choose **Z700-P700 Series**.
  - c From the Settings pop-up menu, choose **Page Attributes**.



## ***Printing envelopes***

You can load up to 10 envelopes, depending on the thickness of the envelopes.

### ***Step 1: Load the envelopes***

**Note:** Do not use envelopes with holes, windows, deep embossing, metal clasps, string ties, or metal folding bars.

- Load the envelopes vertically against the right side of the paper support.

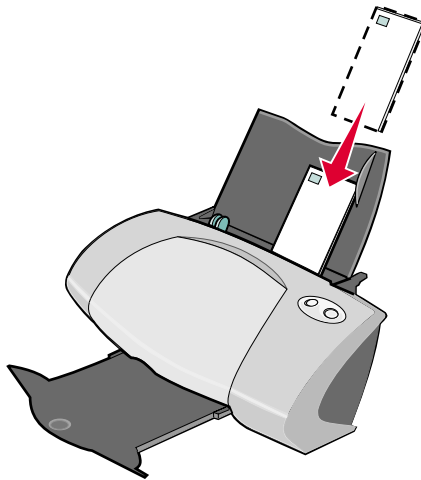

- Make sure your envelopes are not used or damaged.
- Make sure the print side is facing you.
- Make sure the stamp location is in the upper left corner.
- Do not force the envelopes into the printer.

- Squeeze and slide the paper guide to the left edge of the envelopes.

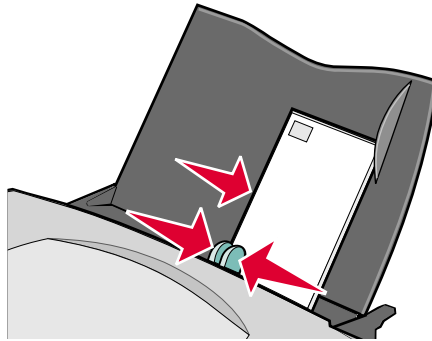

## **Step 2: Customize the print settings**

- 1 Choose an envelope size and orientation:
  - a From the software program, choose **File ▶ Page Setup**.
  - b From the Format for pop-up menu, choose **Z700-P700 Series**.
  - c From the Settings pop-up menu, choose **Page Attributes**.
  - d From the Paper Size pop-up menu, choose an envelope size.
  - e From Orientation, make sure to click the landscape icon.

**Note:** Many software programs are designed to override the envelope settings in Page Setup. Make sure landscape orientation is also selected in your software program.

- f Click **OK**.

- 2 Choose a paper type and print quality:
  - a From the software program, choose **File ▶ Print**.
  - b From the Printer pop-up menu, choose **Z700-P700 Series**.
  - c From the pop-up menu in the upper left corner, choose **Quality & Media**.

**Note:** If Automatic is not chosen in the Paper Type pop-up menu, choose **Plain**. For more information, see “Using the paper type sensor” on page 14.

- d From Print Quality, select your preferred print quality. Normal is the default.

**Note:** Higher print quality settings result in better quality documents, but may take longer to print.



### ***Step 3: Print your envelopes***

Click **Print**.

**Note:** The paper exit tray holds up to 10 envelopes. To print more than 10 envelopes, remove the first 10 envelopes, and then continue printing.

### ***Printing color images in black and white***

You can print color images in black and white.

**Note:** This setting is only available if there is a black print cartridge installed.

### ***Load the paper***

- Load the paper vertically against the right side of the paper support.

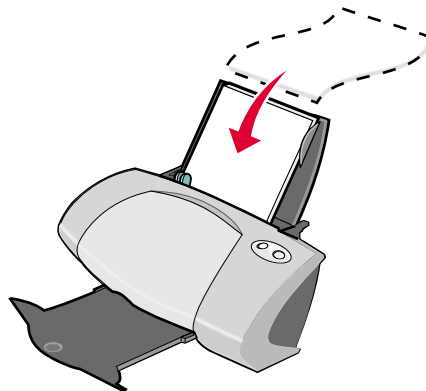

- Make sure your paper is not used or damaged.
- Make sure the print side is facing you.
- Do not force the paper into the printer.

- Squeeze and slide the paper guide to the left edge of the paper.

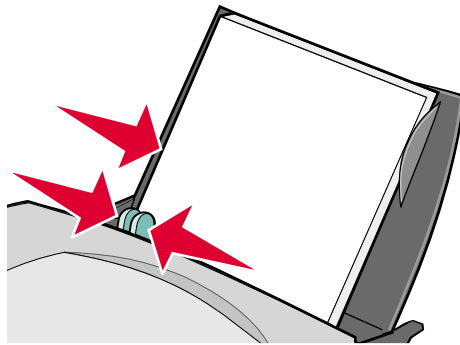

**Note:** If you are using Letter size paper, adjusting the paper guide may not be necessary.

## ***Step 2: Customize the print settings***

- 1 Choose your color options:
  - a From the software program, choose **File ▶ Print**.
  - b From the Printer pop-up menu, choose **Z700-P700 Series**.
  - c From the pop-up menu in upper left corner, choose **Color Options**.
  - d From the Document Color pop-up menu, choose **Black Only**.
- 2 Continue customizing your document following the steps for your paper type.

## ***Step 3: Print your document***

Click **Print**.

**Note:** The paper exit tray holds up to 50 sheets of paper. To print more than 50 sheets of paper, remove the first 50 sheets, and then continue printing.

## ***Printing labels***

You can load up to 25 sheets of labels, depending on the thickness of the sheets.

### ***Step 1: Load the labels***

- Use only labels designed for inkjet printers.

- If your labels include instructions, read them carefully.
- Load the labels vertically against the right side of the paper support.

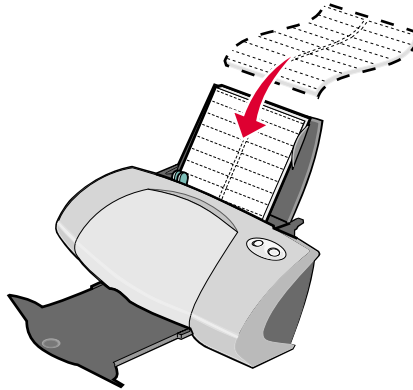

- Make sure your labels are not used or damaged.
- Do not print within 1 mm (0.04 in.) of the edge of a label.
- Make sure there are no missing or curled labels.
- Make sure the print side is facing you.
- Do not force the label sheets into the printer.
- Squeeze and slide the paper guide to the left edge of the sheet of labels.

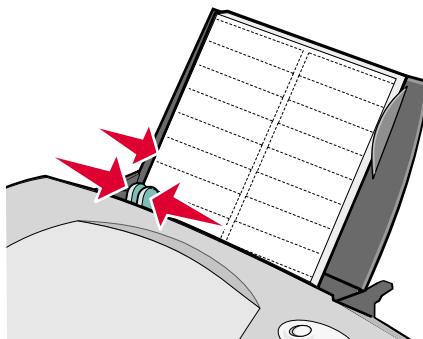

**Note:** If you are using Letter size label paper, adjusting the paper guide may not be necessary.

## **Step 2: Customize the print settings**

**1** Choose a paper size and orientation:

- a** From the software program, choose **File ▶ Page Setup**.
- b** From the Format for pop-up menu, choose **Z700-P700 Series**.
- c** From the Settings pop-up menu, choose **Page Attributes**.
- d** From the Paper Size pop-up menu, choose a paper size.
- e** From Orientation, make sure to click the portrait icon.
- f** Click **OK**.

**2** Choose a paper type and print quality:

- a** From the software program, choose **File ▶ Print**.
- b** From the Printer pop-up menu, choose **Z700-P700 Series**.
- c** From the pop-up menu in the upper left corner, choose **Quality & Media**.

**Note:** If Automatic is not chosen in the Paper Type pop-up menu, choose **Plain**. For more information, see “Using the paper type sensor” on page 14.

- d** From Print Quality, select your preferred print quality. Normal is the default.

**Note:** Higher print quality settings result in better quality documents, but may take longer to print.

## **Step 3: Print your labels**

Click **Print**.

**Note:** The paper exit tray holds up to 10 sheets of labels. To print more than 10 sheets, remove the first 10 sheets, and then continue printing.

## ***Printing handouts***



You can conserve paper by printing handouts. Handouts are multiple pages of a document printed on a single sheet of paper. You can load up to 100 sheets of paper, depending on the thickness of the paper.

### ***Step 1: Load the paper***

- If your paper includes instructions, read them carefully.
- Load the paper vertically against the right side of the paper support.

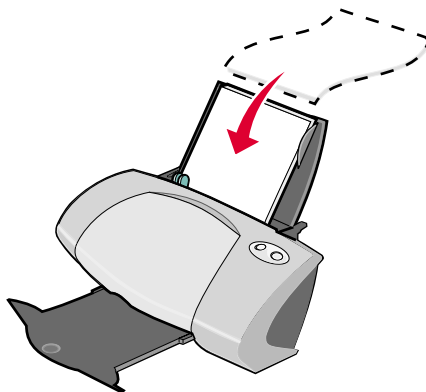

- Make sure your paper is not used or damaged.
- Make sure the print side is facing you.
- Do not force the paper into the printer.

- Squeeze and slide the paper guide to the left edge of the paper.

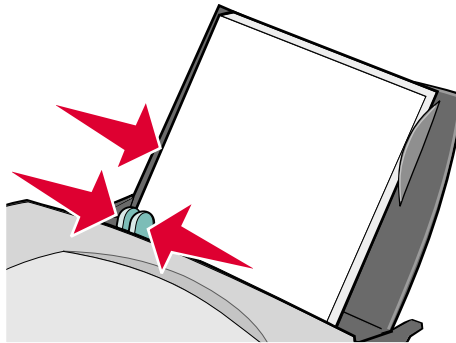

**Note:** If you are using Letter size paper, adjusting the paper guide may not be necessary.

## **Step 2: Customize the print settings**

You can print your handouts on one side or on both sides of the paper.

- 1 Choose a paper size and orientation:
  - a From the software program, choose **File ▶ Page Setup**.
  - b From the Format for pop-up menu, choose **Z700-P700 Series**.
  - c From the Settings pop-up menu, choose **Page Attributes**.
  - d From the Paper Size pop-up menu, choose a paper size.
  - e From Orientation, click the portrait, landscape, or reverse landscape icon.
  - f Click **OK**.
- 2 Choose a print quality, paper type, and layout:
  - a From the software program, choose **File ▶ Print**.
  - b From the Printer pop-up menu, choose **Z700-P700 Series**.
  - c From the pop-up menu in the upper left corner, choose **Quality & Media**.

**Note:** If Automatic is not chosen in the Paper Type pop-up menu, choose a paper type for your document. For more information, see “Using the paper type sensor” on page 14.

- d From Print Quality, select your preferred print quality. Normal is the default.
- Note:** Higher print quality settings result in better quality documents, but may take longer to print.
- e From the pop-up menu in the upper left corner, choose **Layout**.
- f From the Pages per Sheet pop-up menu, choose the number of pages you want to print on one sheet.
- g From Layout Direction, click the graphic that shows the order you want the pages to print on the sheet.
- h If you want to print a border around each image, choose an option from the Border pop-up menu.

### ***Step 3: Print your handouts***

Click **Print**.

### ***Printing iron-on transfers***

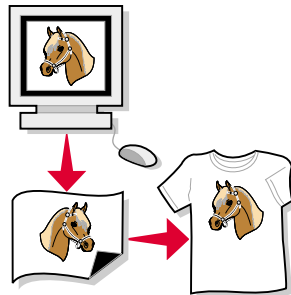

You can load up to 100 iron-on transfers, depending on the thickness of the iron-on transfers. You may want to print your image on plain paper before printing it on an iron-on transfer. This ensures you do not waste iron-on transfers perfecting the image you want to print. When the image prints to your satisfaction, load the iron-on transfers.

**Note:** For best results, load iron-on transfers one at a time.

### ***Step 1: Load the iron-on transfers***

- If your iron-on transfers include instructions, read them carefully.

- Load the iron-on transfers vertically against the right side of the paper support.

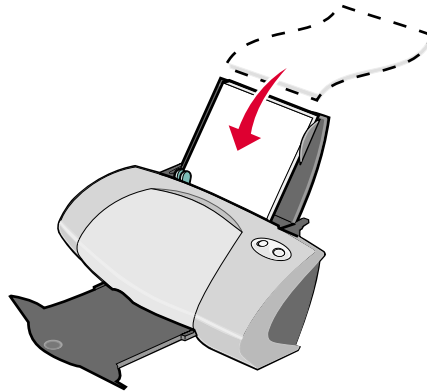

- Make sure your iron-on transfers are not used or damaged.
- Make sure the print (blank) side is facing you.
- Do not force the iron-on transfers into the printer.
- Squeeze and slide the paper guide to the left edge of the iron-on transfers.

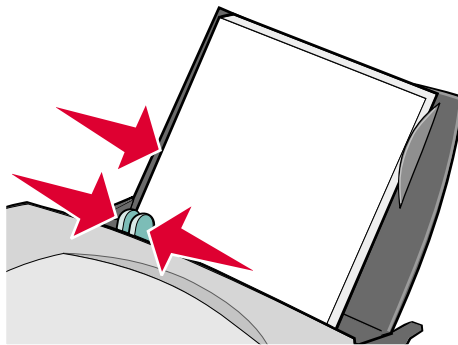

**Note:** If you are using Letter size iron-on transfers, adjusting the paper guide may not be necessary.

## **Step 2: Customize the print settings**

- 1 Choose a paper size and orientation:
  - a From the software program, choose **File ▶ Page Setup**.
  - b From the Format for pop-up menu, choose **Z700-P700 Series**.
  - c From the Settings pop-up menu, choose **Page Attributes**.



- d From the Paper Size menu, choose a paper size.
- e From Orientation, click the portrait, landscape, or reverse landscape icon.
- f Click **OK**.

**2** Choose a paper type and print quality:

- a From the software program, choose **File ▶ Print**.
- b From the Printer pop-up menu, choose **Z700-P700 Series**.
- c From the pop-up menu in the upper left corner, choose **Quality & Media**.
- d From the Paper Type pop-up menu, choose **Iron-On Transfer**.

**Note:** Choosing Iron-On Transfer automatically mirrors the image you want to print. Make sure you *do not* select an option from your software program that will mirror your image.

- e From Print Quality, select your preferred print quality. Normal is the default.

**Note:** Higher print quality settings result in better quality documents, but may take longer to print.

- f If your software program also mirrors the image, follow these steps:
  - From the pop-up menu in the upper left corner, choose **Advanced Layout**.
  - Make sure **Mirror** is not selected.

### ***Step 3: Print your iron-on transfers***

Click **Print**.

**Note:** To prevent smudging, remove each iron-on transfer as it exits the printer, and then let it dry before stacking.

## ***Printing transparencies***

You can load up to 50 transparencies, depending on the thickness of the transparencies.

### ***Step 1: Load the transparencies***

- Use transparencies designed for inkjet printers.
- If the transparencies have paper backing sheets, make sure you separate the paper from the transparencies before you load them.
- If your transparencies include instructions, read them carefully.

- Load the transparencies vertically against the right side of the paper support.

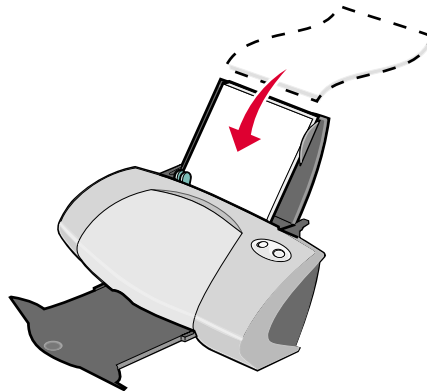

- Make sure your transparencies are not used or damaged.
- Make sure the rough (print) side of the transparencies is facing you. If the transparencies have a removable strip, make sure each strip is facing away and down toward the printer.
- Do not force the transparencies into the printer.
- Squeeze and slide the paper guide to the left edge of the transparencies.

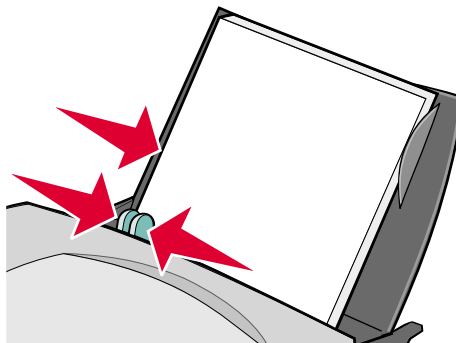

**Note:** If you are using Letter size transparency paper, adjusting the paper guide may not be necessary.

## **Step 2: Customize the print settings**

- 1 Choose a paper size and orientation:
  - a From the software program, choose **File ▶ Page Setup**.
  - b From the Format for pop-up menu, choose **Z700-P700 Series**.
  - c From the Settings pop-up menu, choose **Page Attributes**.

- d From the Paper Size pop-up menu, choose a paper size.
- e From Orientation, click the portrait, landscape, or reverse landscape icon.
- f Click **OK**.

**2** Choose a paper type and print quality:

- a From the software program, choose **File ▶ Print**.
- b From the Printer pop-up menu, choose **Z700-P700 Series**.
- c From the pop-up menu in the upper left corner, choose **Quality & Media**.

**Note:** If Automatic is not chosen in the Paper Type pop-up menu, choose **Transparency**. For more information, see “Using the paper type sensor” on page 14.

- d From Print Quality, select your preferred print quality. Normal is the default.

**Note:** Higher print quality settings result in better quality documents, but may take longer to print.

### ***Step 3: Print your transparencies***

Click **Print**.

**Note:** To prevent smudging, remove each transparency as it exits the printer, and then let it dry before stacking. Transparencies may require up to 15 minutes to dry.

## ***Printing your document in reverse order***

### ***Step 1: Load the paper***

- Load the paper vertically against the right side of the paper support.

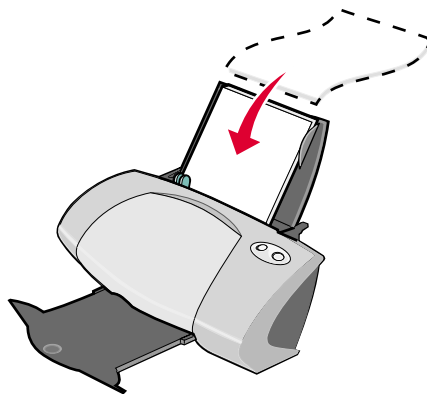

- Make sure the print side is facing you.
- Do not force the paper into the printer.
- Squeeze and slide the paper guide to the left edge of the paper.

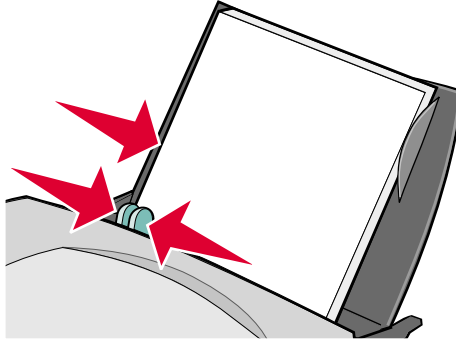

**Note:** If you are using Letter size paper, adjusting the paper guide may not be necessary.

## ***Step 2: Customize the print settings***

- 1 Choose a paper size and orientation:
  - a From the software program, choose **File ▶ Page Setup**.
  - b From the Paper Size pop-up menu, choose a paper size.
  - c From Orientation, click the portrait, landscape, or reverse landscape icon.
  - d Click **OK**.
- 2 Choose a layout for your document:
  - a From the software program, choose **File ▶ Print**.
  - b From the Printer pop-up menu, choose **Z700-P700 Series**.
  - c From the pop-up menu in the upper left corner, choose **Advanced Layout**.
  - d Click the **Print Last Page First** check box.

## ***Step 3: Print your document***

Click **Print**.

**Note:** The paper exit tray holds up to 50 sheets of paper. If you want to print more than 50 sheets, remove the first 50 sheets, and then continue printing.

# 3

## Maintenance

### *Replacing the print cartridges*

The Z700-P700 Series uses the following cartridges:

Left cartridge carrier: Color cartridges only	Right cartridge carrier: Black or Photo cartridges
19	48
20	50
25	55
	90 (Photo)

**Note:** You can use the printer with just a color cartridge or just a black cartridge. You must have a color cartridge installed when you print with a photo cartridge.

For information about ordering supplies, see page 44.

### *Remove the used cartridges*

- 1 Make sure the power light is on.
- 2 Raise the front cover.

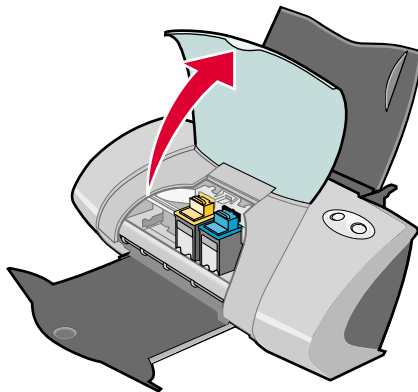

The cartridge carrier moves to the loading position, unless the printer is busy.

- 3** Pull the cartridges towards you until you hear a *snap*.

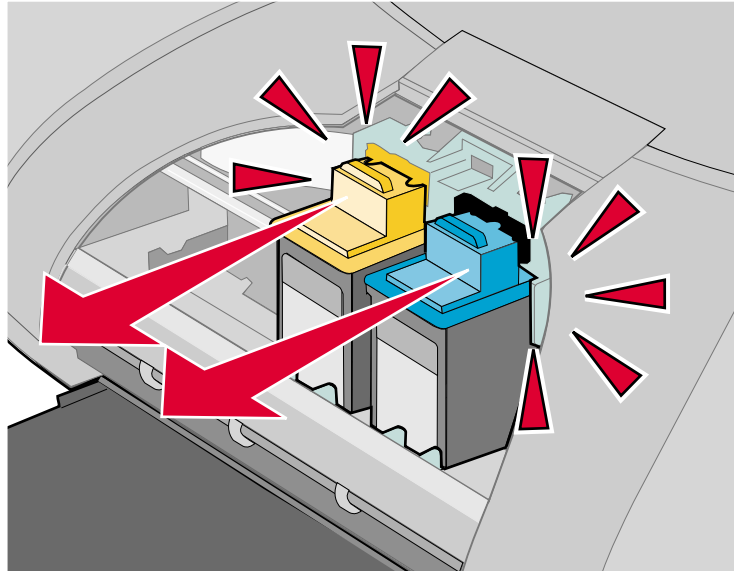

- 4** Remove the used cartridges. Store them in an airtight container or dispose of them properly. When removing the photo cartridge to exchange it with a black cartridge, store the photo cartridge in the storage unit provided.

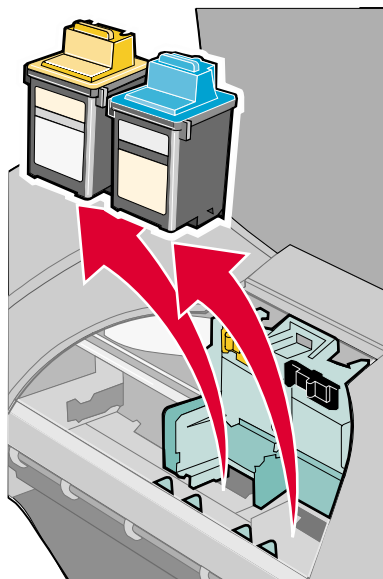

## Install the cartridges

- 1 If you are installing new cartridges, remove the sticker and transparent tape from the back and bottom of each print cartridge.

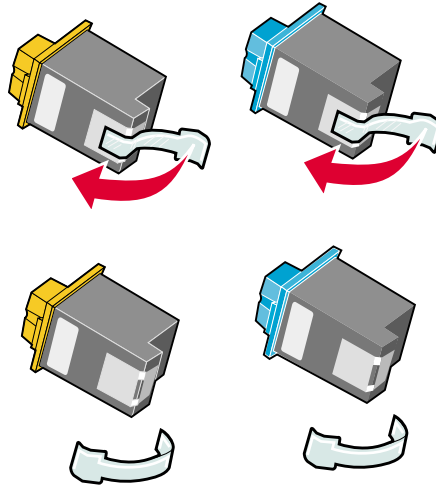

**Warning:** Do *not* touch or remove the gold contact area on the back and bottom of each print cartridge.

- 2 Insert the color cartridge in the left carrier. Insert the black or photo cartridge in the right carrier.

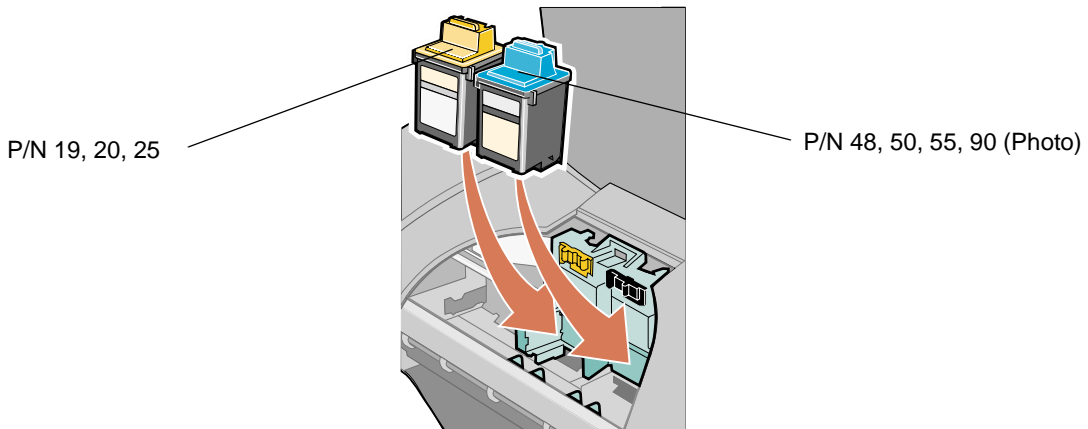

**Note:** To extend the life of your color cartridge and improve printing speed, install a black or photo cartridge along with the color cartridge.

- 3 Snap the cartridges into place.

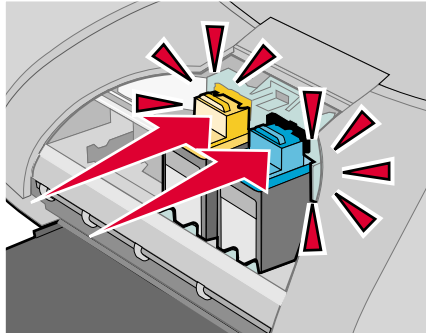

- 4 Close the front cover.

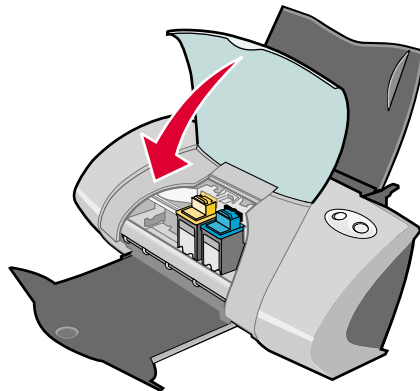

**Note:** The front cover must be closed to start a print job.

## ***Specifying cartridge settings in the printer software***

Before you specify the print cartridge settings in the printer software, install the cartridges. For help, see “Install the cartridges” on page 39.

- 1 After installing the cartridges, open the printer utility by double-clicking the **Z700-P700 Series Printer** folder on your desktop, and then double-clicking **Z700-P700 Series Utility**. You can also access the Z700-P700 Series Utility from Printer Services in the Print dialog menu.
- 2 From the Cartridges tab, click **Install/Change Cartridge**. Follow the instruction on the screen to install the cartridges.



**3** Click **Continue**.

The Cartridge Verification dialog appears.

**4** Select the part numbers of the cartridges you are installing.

**5** Select **Yes, it is old** if the cartridge has been used before, or **No, it is new** if the cartridge has not been used before.

**Note:** If an old cartridge is incorrectly identified as new cartridge, ink levels in the printer utility may be incorrect.

**6** Click **OK**.

## ***Aligning the print cartridges***

Typically, you only align print cartridges after installing or replacing a cartridge. However, you may also need to align cartridges when:

- Characters are improperly formed or are misaligned at the left margin.
- Vertical, straight lines are wavy.

To align the cartridges:

**1** Load paper.

**2** Open the printer utility by double-clicking the **Z700-P700 Series Printer** folder on your desktop, and then double-clicking **Z700-P700 Series Utility**. You can also access the Z700-P700 Series Utility from Printer Services in the Print dialog menu.

**3** From the Cartridges tab, click **Align Cartridges**.

The Cartridge Alignment dialog appears.

**4** Click **Continue** to print the alignment page.

**5** On the Alignment Status dialog, click **OK** if automatic alignment is successful.

If automatic alignment is not successful, click **Yes** to print a manual alignment page.

**6** Find the number under the darkest arrow for each alignment group on the printed alignment page.

**7** On the screen, use the arrows in the Align Cartridges dialog to select the number that matches the darkest arrow on the printed page for each alignment group.

**8** Click **OK**.

If the alignment page does not print, see “Alignment page does not print” on page 52.

## *Improving print quality*

If you are not satisfied with the print quality of your document, first make sure you:

- Use the appropriate paper for the document. For example, use photo paper if you are printing a photo.
- Use paper that is heavier, bright white, or coated.
- Select a higher print quality:
  - 1 From the software program, choose **File ▶ Print**.
  - 2 From the pop-up menu in the upper left corner, choose **Quality & Media**.
  - 3 Select **Better** or **Best**.

If your document still does not have the print quality you want, follow these steps:

- 1 Reinsert the print cartridges.
  - a Remove the print cartridges. For help, see “Remove the used cartridges” on page 37.
  - b Insert the print cartridges. For help, see “Install the cartridges” on page 39.
  - c Align the print cartridges. For help, see “Aligning the print cartridges” on page 41.
  - d Print your document again.
  - e If the print quality has not improved, clean the print cartridge nozzles.
- 2 Clean the print cartridge nozzles.
  - a Load paper.
  - b Open the printer utility by double-clicking the **Z700-P700 Series Printer** folder on your desktop, and then double-clicking **Z700-P700 Series Utility**. You can also access the Z700-P700 Series Utility from Printer Services in the Print dialog menu.
  - c From the Cartridges tab, click **Clean Print Nozzles**.

A nozzle page prints, forcing ink through the nozzles to clean any that are clogged.
  - d Print your document again to verify that your print quality has improved.
  - e To further improve print quality, continue with step 3.
- 3 Wiping the print cartridge nozzles and contacts.

If the print quality has not improved after cleaning the print cartridge nozzles, there may be dried ink on the nozzles or contacts.

- a Remove the print cartridges. For help, see “Remove the used cartridges” on page 37.
- b Dampen a clean, lint-free cloth with water.

- c Gently hold the cloth against the nozzles for about three seconds, and then wipe in the direction shown.

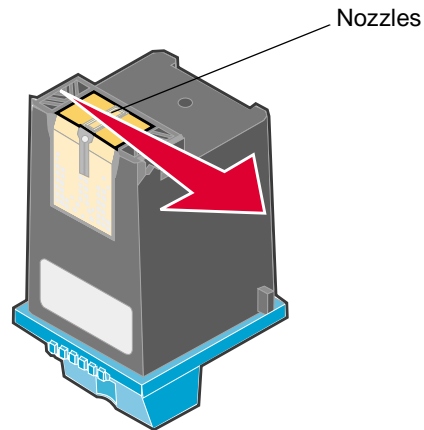

- d Gently hold a clean section of the cloth against the contacts for about three seconds, and then wipe in the direction shown.

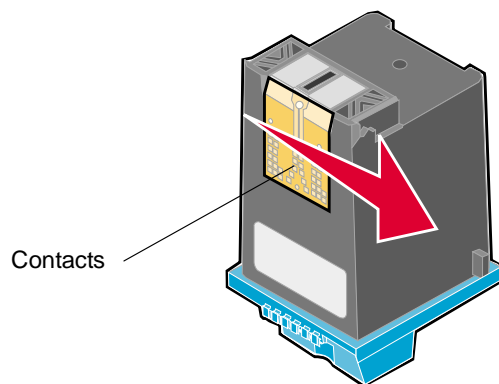

- e Allow the nozzles and contacts to dry completely.
- f Reinstall the print cartridges, and then print your document again.

If the print quality has not improved, clean the print cartridge nozzles up to two more times.

If print quality is still unsatisfactory, replace your print cartridges. For help, see “Replacing the print cartridges” on page 37.

## ***Preserving the print cartridges***

To ensure the longest life from your print cartridges and optimum performance from your printer:

- Keep a new print cartridge in its packaging until you are ready to install it.
- Do not remove a print cartridge from the printer except to replace, clean, or store it in an airtight container. The print cartridges do not print correctly if left exposed for an extended period.
- Keep the photo cartridge in its own storage unit when not in use.

Lexmark's printer warranty does not cover repair of failures or damage caused by a refilled cartridge. We do not recommend the use of refilled cartridges. Refilling cartridges can affect print quality and cause damage to the printer. For best results, use Lexmark supplies.

## ***Ordering supplies***

To order supplies or locate a dealer near you, contact the Lexmark Web site at [www.lexmark.com](http://www.lexmark.com).

<b>Item:</b>	<b>Part number:</b>
Color cartridge	19 20 25
Black cartridge	48 50 55
Photo cartridge	90
USB cable	12A2405

# 4

## Setup troubleshooting

---

### *Troubleshooting checklist*

- Is the power supply firmly attached to your printer and a properly grounded electrical outlet?
- Are both your printer and computer on? If you are using your printer on a network, make sure your computer is connected to the network, your Lexmark adapter is on, and all indicator lights are on. For more information, refer to the adapter documentation.
- Is your USB cable securely attached to your printer and to your computer or Lexmark adapter?
- Are the printer lights blinking? If they are, see “Understanding error messages and flashing lights” on page 49.
- Did you remove the sticker and transparent tape from the back and bottom of each print cartridge?
- Did you install the print cartridges correctly? For help, see “Install the cartridges” on page 39.
- Is the paper loaded correctly? Make sure you do not push the paper too far into the printer. If the Paper Feed light is blinking, see “Understanding error messages and flashing lights” on page 49.
- Did you install the printer software correctly?

Open the printer utility by double-clicking the **Z700-P700 Series Printer** folder on your desktop, and then double-clicking **Z700-P700 Series Utility**. You can also access the Z700-P700 Series Utility from Printer Services in the Print dialog menu.

If the printer folder and the printer utility are not found, relaunch the printer software. For help, see “Installing the printer software” on page 47.

- Is the printer set as the default or current printer?

To make sure that your printer is set as the default printer:

- 1 From the Dock, click the **Print Center** icon.

The Printer List dialog appears.

**Note:** If the Print Center icon is not on the Dock, from the Finder window choose **Go ▶ Applications ▶ Utilities ▶ Print Center**.

- 2 Make sure that the **Z700-P700 Series** is highlighted in the list.

To make sure that your printer is set as the current printer:

- 1 With your document open, choose **File ▶ Page Setup**.
- 2 From the Format for pop-up menu, choose **Z700-P700 Series**.
- 3 Click **OK**.
- 4 Choose **File ▶ Print**.
- 5 From the Printer pop-up menu, choose **Z700-P700 Series**.

- Is your printer directly connected to your computer? If it is connected through an external device such as a USB hub, switch box, scanner, or fax machine, follow these corrective steps:

- 1 Disconnect your printer from any external devices.
- 2 Connect your printer directly to your computer with a USB cable.
- 3 Print a test page.
  - a Open the printer utility by double-clicking the **Z700-P700 Series Printer** folder on your desktop, and then double-clicking **Z700-P700 Series Utility**. You can also access the Z700-P700 Series Utility from Printer Services in the Print dialog menu.
  - b From the Cartridges tab, click **Print Test Page**.
    - If the test page prints, the printer is working properly. The initial problem may be due to your external devices, not your printer. Check the documentation that comes with your external devices for help.
    - If the test page does not print, refer to the printer software Help for further troubleshooting information. See also "Test page does not print" on page 52.

## ***When I insert the printer software CD, nothing happens***

- 1 Close all open software programs.
- 2 Remove the printer software CD.

*When I insert the printer software CD, nothing happens*

- 3 Restart your computer.
- 4 When your desktop appears, reinsert the printer software CD.  
The Lexmark Z700-P700 Series CD icon is created on your desktop.
- 5 Follow the instructions in “Installing the printer software” on page 47 to complete the printer software installation.

## ***Solving printer software installation problems***

If the printer software does not install properly, a communications error message appears when you try to print. You may need to remove the printer software, and then reinstall it.

### ***Removing the printer software***

There are two ways to remove the printer software. One way to remove it is as follows:

- 1 From your desktop, double-click the **Lexmark Z700-P700 Series CD** icon. If the CD icon is not on your desktop, insert the printer software CD to relaunch it.  
The Lexmark Installer screen appears.
- 2 Double-click **Install**.  
The Lexmark Z700-P700 Series Installation menu appears.
- 3 Click **Uninstall**.  
Complete the user authentication notice if it appears, and then click **OK**.
- 4 Follow the steps on your screen to complete printer software removal.

Another way to remove the printer software is as follows:

- 1 From your desktop, double-click the **Z700-P700 Series Printer** folder.  
The Z700-P700 Series Printer menu appears.
- 2 Double-click the **Z700-P700 Series Uninstaller**.  
Complete the user authentication notice if it appears, and then click **OK**.
- 3 Click **Uninstall**.
- 4 Follow the steps on your screen to complete printer software removal.

### ***Installing the printer software***

Restart your computer before installing or reinstalling the printer software.

You can install the printer software using the CD that comes with your printer, or you can download it from the Lexmark Web site at [www.lexmark.com](http://www.lexmark.com).

To connect your printer to a network with a Lexmark adapter, refer to the documentation that comes with your adapter.

## Using the CD that comes with your printer

- 1 Close all open software programs.
- 2 When your desktop appears, insert the printer software CD.  
The Lexmark Z700-P700 Series CD icon appears on your desktop.
- 3 Double-click the **Lexmark Z700-P700 Series CD** icon.
- 4 Double-click **Install**.
- 5 Click **Install and Agree**.
- 6 Choose the country or region closest to you, and then click **Continue**.

**Note:** If the Printer Selection or the New Network Printer Found dialog appears, follow the instructions displayed. Click ? on the screen or contact your network administrator for help.

- 7 Follow the instructions on the screen to complete printer software installation.
- 8 When printer software installation is complete, you can:
  - Register your printer on the Internet.
  - Print a test page to observe your printer in action.
  - Check the Lexmark Web site for offers (United States and Canada only).
- 9 Click **Finished** when you are done.
- 10 The Z700-P700 Series Printer folder is automatically created on your desktop. You are now ready to start using your Lexmark Z700-P700 Series printer.

## Using the World Wide Web

Installing the printer software from the Web is as easy as:

- 1 Make sure Stuffit Expander is loaded on your system.
- 2 Access the Lexmark Web site, [www.lexmark.com](http://www.lexmark.com).
- 3 On the home page, navigate through the menu selection and click **Drivers & Downloads**.
- 4 Select the printer and the printer driver for your operating system.
- 5 Follow the instructions on the screen to download the driver and install the printer software.



# 5

## General troubleshooting

---

For information about:	See page:
Solving network printing problems	49
Understanding error messages and flashing lights	49
Resolving unsuccessful or slow printing	51
Clearing paper misfeeds or jams	53
Solving print quality problems	55
Solving specialty media problems	57

### ***Solving network printing problems***

If you are connected to a network with a Lexmark adapter, see the adapter documentation for troubleshooting information.

### ***Understanding error messages and flashing lights***

Use this section to understand printer software error messages on your computer screen and blinking lights on your printer. For information about lights on a Lexmark adapter, refer to the adapter documentation.

#### ***Paper Jam message***

For help clearing a paper jam, see “Printer has a paper jam” on page 54.

#### ***Ink Low message***

A print cartridge is running out of ink. To order a new cartridge or locate a dealer near you, see “Ordering supplies” on page 44, or contact the Lexmark Web site at [www.lexmark.com](http://www.lexmark.com). For help in replacing the cartridges, see “Replacing the print cartridges” on page 37.

## ***Paper Feed light is blinking***

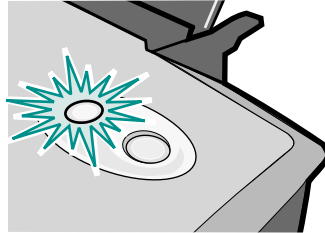

If the printer is out of paper:

- 1 Load paper.
- 2 Press the **Paper Feed** button.

If the printer has a paper jam, see “Printer has a paper jam” on page 54.

## ***Power light is flashing***

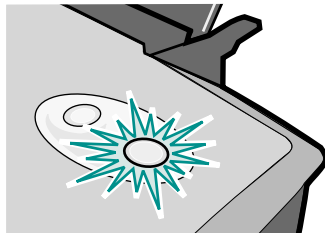

The print cartridge carrier is stalled.

- 1 Check your computer screen for error messages.
- 2 Turn the printer off.
- 3 Wait a few seconds, and then turn the printer back on.

If the cartridge carrier is stalled due to a paper jam, see “Printer has a paper jam” on page 54.

## ***Resolving unsuccessful or slow printing***

The following topics can help you correct unsuccessful or slow printing.

### ***Printer is plugged in, but does not print***

Make sure:

- The printer is on and the printer cable is securely attached at both ends. If your printer is connected to a network, make sure the Lexmark adapter is on and all indicator lights are on. For help, refer to the adapter documentation.
- The paper is loaded correctly and not pushed too far into the printer. If the paper is jammed, see “Clearing paper misfeeds or jams” on page 53.
- The printer is not held or paused. To check the printer status:

- 1 From the Dock, click the **Print Center** icon.

The Printer List dialog appears.

**Note:** If the Print Center icon is not on the Dock, from the Finder window choose **Go ▶ Applications ▶ Utilities ▶ Print Center**.

- 2 Highlight the **Z700-P700 Series** in the list.
  - 3 From the Queue drop-down menu, choose **Start Queue**.
  - 4 From the Printers drop-down menu, choose **Show Queue** or **Show Jobs**.
  - 5 Select your job from the list.
  - 6 Click **Resume**.
- The printer is set as the default printer. To set the printer as the default:

- 1 From the Dock, click the **Print Center** icon.

The Printer List dialog appears.

**Note:** If the Print Center icon is not on the Dock, from the Finder window choose **Go ▶ Applications ▶ Utilities ▶ Print Center**.

- 2 Make sure that the **Z700-P700 Series** is highlighted in the list.

After you check these items, print a test page.

## ***Printing a test page***

- 1 Access the printer utility by double-clicking the **Z700-P700 Series Printer** folder on your desktop, and then double-clicking **Z700-P700 Series Utility**. You can also access the Z700-P700 Series Utility from Printer Services in the Print dialog menu.
- 2 From the Cartridges tab, click **Print Test Page**.
  - If the test page prints, the printer is working properly.
  - If the test page does not print, continue with the following section or refer to the printer software Help for further troubleshooting information.

## ***Test page does not print***

For help, first see “Troubleshooting checklist” on page 45, and then:

- If the paper is jammed, see “Clearing paper misfeeds or jams” on page 53.
- Make sure the printer is not held or paused. To check the printer status:

- 1 From the Dock, click the **Print Center** icon.

The Printer List dialog appears.

**Note:** If the Print Center icon is not on the Dock, from the Finder window choose **Go** ▶ **Applications** ▶ **Utilities** ▶ **Print Center**.

- 2 Highlight the **Z700-P700 Series** in the list.
- 3 From the Queue drop-down menu, choose **Start Queue**.
- 4 From the Printers drop-down menu, choose **Show Queue** or **Show Jobs**.
- 5 Select your job from the list.
- 6 Click **Resume**.
- 7 Print your test page again. If it still does not print, see “Solving printer software installation problems” on page 47.

## ***Alignment page does not print***

Make sure:

- You completely removed the transparent tape and sticker from the back and bottom of each print cartridge.
- You installed the cartridges correctly. For help, see “Install the cartridges” on page 39.
- You loaded the paper correctly and did not force the paper into the printer.
- If you are connected to a network with a Lexmark adapter, the indicator lights are on. For more information, see the adapter documentation.

## ***Printer ejects a blank page after appearing to print***

Make sure:

- You remove the sticker and transparent tape from the back and bottom of each print cartridge. For help, see “Replacing the print cartridges” on page 37.
- Your cartridges do not have clogged nozzles. Clean the print cartridge nozzles. Follow the steps in “Improving print quality” on page 42.

## ***Printer prints very slowly***

- If you are using a Mac OS X version prior to 10.1, consider upgrading to enhance print system performance.
- Close any software programs not in use.
- Check the document you are printing. Photos and graphics may take longer to print than regular text. Documents that are large or that contain background images may also take longer to print.
- Check the printer to see if another document is being printed. Print jobs are printed in the order the printer receives them.
- Decrease the print quality setting to **Normal** or **Quick Print**.

**Note:** Higher print quality settings result in better quality documents, but may take longer to print.

## ***Clearing paper misfeeds or jams***

The following topics can help you correct paper misfeeds or jams.

### ***Paper misfeeds or multiple sheets feed***

Make sure:

- The edges of your paper are not curled.
- Your paper is designed for inkjet printers.
- A piece of paper from a previous print job is not jammed.
- You do not load too much paper. Depending on the weight of the paper, you can load up to 100 sheets of paper.
- You do not force the paper into the printer.
- The paper guide is against the left edge of the paper.
- The paper guide does not cause the paper to bow.

- The printer is on a flat, level surface.
- The printer settings you have chosen are correct for the type of document you are printing. For help, see “Printing ideas” on page 15.

## ***Printer does not feed specialty media***

Make sure:

- Your printer feeds paper without problems. Load the specialty media vertically against the right side of the paper support. Squeeze and slide the paper guide to the left edge of the specialty media. For help, see “Printing ideas” on page 15.
- You select the appropriate media or specialty media size. See “Page Setup dialog” on page 9 and “Print dialog” on page 10.
- You are using a specialty media size supported by your printer.
- Your software program is designed to print your specialty media. For help, check your software program documentation.
- The specialty media is not jammed. For help, see “Printer has a paper jam” on page 54.
- Your printer is not held or paused. To check the printer status:

- 1 From the Dock, click the **Print Center** icon.

The Printer List dialog appears.

**Note:** If the Print Center icon is not on the Dock, from the Finder window choose **Go ▶ Applications ▶ Utilities ▶ Print Center**.

- 2 Make sure that the **Z700-P700 Series** is highlighted in the list.
- 3 From the Queue drop-down menu, choose **Start Queue**, if available.
- 4 From the Printers drop-down menu, choose **Show Queue** or **Show Jobs**.
- 5 Select your print job from the list.
- 6 Click **Resume** or **Retry**.

## ***Printer has a paper jam***

If the paper is lodged too far into the printer and cannot be removed:

- 1 Turn the printer off.
- 2 Turn the printer back on.

**3** If the printer does not automatically eject the page:

- a** Turn the printer off.
- b** Pull firmly on the paper to remove it.

If you cannot reach the paper, raise the front cover, pull the paper out, and then close the front cover.

- c** Turn the printer on.

## ***Solving print quality problems***

If print quality is unsatisfactory, you may need to adjust the margin settings, choose a higher print quality, align the print cartridges, or clean the nozzles.

The following topics can help you improve print quality:

### ***Print is too dark or smudged***

- Make sure the paper is straight and not wrinkled.
- Let the ink dry completely before handling the paper.
- Make sure the paper type and paper size settings in the printer software match the paper loaded in the printer. For help, see “Using the printer software” on page 9.
- Change the print quality setting to **Quick Print**.
- Clean the print cartridge nozzles. Follow the steps in “Improving print quality” on page 42.

### ***Vertical straight lines are not smooth***

To improve the print quality of vertical straight lines in tables, borders, and graphs:

- Select a higher print quality.
- Align the print cartridge nozzles. For help, see “Aligning the print cartridges” on page 41.
- Clean the print cartridge nozzles. Follow the steps in “Improving print quality” on page 42.

### ***Print smears on the page***

- The next page exiting the printer may be smearing the ink. Remove each page as it exits the printer, and then let it dry completely before stacking.
- Clean the print cartridge nozzles. Follow the steps in “Improving print quality” on page 42.

## ***Printed pages have alternating bands of light and dark print (intermittent printing)***

- Change the print quality to **Better** or **Best**.
- If your printer is connected to your computer through a hub or peripheral device, such as a scanner or fax machine, connect the printer directly to your computer with a USB cable.
- If your printer is connected to your network, connect the printer directly to your computer with a USB cable.

## ***Print quality is poor at the edges***

- Make sure that the Lexmark printer is the default printer.
- Clean the print cartridge nozzles and contacts. Follow the steps in “Improving print quality” on page 42.
- Print your document without borders.

If you print your document with borders, make sure your margins are set within the following margin settings.

<b>Margin:</b>	<b>Minimum setting:</b>
Left and right	<ul style="list-style-type: none"><li>• 6.35 mm (0.25 in.) for U.S. Letter, U.S. Legal, Banner Letter, and custom paper sizes</li><li>• 3.175 mm (0.125 in.) for envelopes</li><li>• 3.37 mm (0.13 in.) for most paper sizes</li></ul>
Top	<ul style="list-style-type: none"><li>• 1.7 mm (0.067 in.)</li></ul>
Bottom	<ul style="list-style-type: none"><li>• 12.7 mm (0.5 in.) for black print jobs</li><li>• 19 mm (0.75 in.) recommended for color print jobs</li></ul>

## ***Printed characters are improperly formed or misaligned***

- Cancel all print jobs and print your job again. To cancel all print jobs:

- 1** From the Dock, click the **Print Center** icon.

The Printer List dialog appears.

**Note:** If the Print Center icon is not on the Dock, from the Finder window choose **Go ▶ Applications ▶ Utilities ▶ Print Center**.

- 2** Make sure that the **Z700-P700 Series** is highlighted in the list.
- 3** From the Queue drop-down menu, choose **Start Queue**.
- 4** From the Printers drop-down menu, choose **Show Queue** or **Show Jobs**.



- 5 Select the job you want to delete.
  - 6 Click **Delete**.
  - 7 Repeat steps 5 through 6 until all jobs are deleted.
- Align the print cartridges. For help, see “Aligning the print cartridges” on page 41.
  - Clean the print cartridge nozzles. Follow the steps in “Improving print quality” on page 42.

### ***Colors on the printout differ from the colors on the screen***

- A cartridge may be low on ink. For help, see “Replacing the print cartridges” on page 37.
- Use a different paper brand. Each paper brand accepts ink differently and prints with color variations.
- Select Natural Color as the document color:
  - 1 From the software program, choose **File ▶ Print**.
  - 2 From the Printer pop-up menu, choose **Z700-P700 Series**.
  - 3 From the pop-up menu in the upper left corner, choose **Color Options**.
  - 4 From the Document Color pop-up menu, choose **Natural Color**.

### ***Colors on the printout are faded***

Try the suggestions listed in the section “Colors on the printout differ from the colors on the screen” on page 57. If the colors still seem faded, clean the print cartridge nozzles. Follow the steps in “Improving print quality” on page 42.

### ***Characters are missing or unexpected***

Clean the print cartridge nozzles. Follow the steps in “Improving print quality” on page 42.

### ***Photos do not print as expected***

- Select a higher print quality.
- Choose photo paper as the paper type.

### ***Solving specialty media problems***

The following topics can help you solve problems with specialty media.

### ***Glossy/photo papers or transparencies stick together***

- Use glossy/photo paper or transparency designed for inkjet printers.
- Make sure you loaded the paper correctly (with print side facing you) and selected the appropriate settings in the printer software. For help, see “Printing photos” on page 16 or “Printing transparencies” on page 33.
- Remove each page as it exits the printer, and then let it dry completely before stacking.

### ***Transparencies or photos contain white lines***

- Make sure you loaded the paper correctly (with print side facing you) and selected the appropriate settings in the printer software. For help, see “Printing transparencies” on page 33 or “Printing photos” on page 16.
- Select a higher print quality, such as **Better** or **Best**. For help, see “Printing ideas” on page 15.
- Clean the print cartridge nozzles. Follow the steps in “Improving print quality” on page 42.

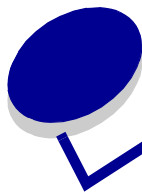

# Notices

---

## Electronic emission notices

### Federal Communications Commission (FCC) compliance information statement

The Lexmark Z700 Series Color Jetprinter, type 4136-001, and Lexmark P700 Series Photo Jetprinter, type 4136-0P1, has been tested and found to comply with the limits for a Class B digital device, pursuant to Part 15 of the FCC Rules. Operation is subject to the following two conditions: (1) this device may not cause harmful interference, and (2) this device must accept any interference received, including interference that may cause undesired operation.

The FCC Class B limits are designed to provide reasonable protection against harmful interference in a residential installation. This equipment generates, uses and can radiate radio frequency energy and, if not installed and used in accordance with the instructions, may cause harmful interference to radio communications. However, there is no guarantee that interference will not occur in a particular installation. If this equipment does cause harmful interference to radio or television reception, which can be determined by turning the equipment off and on, the user is encouraged to try to correct the interference by one or more of the following measures:

- Reorient or relocate the receiving antenna.
- Increase the separation between the equipment and receiver.
- Connect the equipment into an outlet on a circuit different from that to which the receiver is connected.
- Consult your point of purchase or service representative for additional suggestions.

The manufacturer is not responsible for any radio or television interference caused by using other than recommended cables or by unauthorized changes or modifications to this equipment. Unauthorized changes or modifications could void the user's authority to operate this equipment.

**Note:** To assure compliance with FCC regulations on electromagnetic interference for a Class B computing device, use a properly shielded and grounded cable such as Lexmark part number 1329605 for parallel attach or 12A2405 for USB attach. Use of a substitute cable not properly shielded and grounded may result in a violation of FCC regulations.

Any questions regarding this compliance information statement should be directed to:

Director of Lexmark Technology & Services  
Lexmark International, Inc.  
740 West New Circle Road  
Lexington, KY 40550  
(859) 232-3000

### Industry Canada compliance statement

This Class B digital apparatus meets all requirements of the Canadian Interference-Causing Equipment Regulations.

### Avis de conformité aux normes de l'industrie du Canada

Cet appareil numérique de la classe B respecte toutes les exigences du Règlement sur le matériel brouilleur du Canada.

### European Community (EC) directives conformity

This product is in conformity with the protection requirements of EC Council directives 89/336/EEC and 73/23/EEC on the approximation and harmonization of the laws of the Member States relating to electromagnetic compatibility and safety of electrical equipment designed for use within certain voltage limits.

A declaration of conformity with the requirements of the directives has been signed by the Director of Manufacturing and Technical Support, Lexmark International, S.A., Boigny, France.

This product satisfies the Class B limits of EN 55022 and safety requirements of EN 60950.

### The United Kingdom Telecommunications Act 1984

This apparatus is approved under the approval number NS/G/1234/J/100003 for the indirect connections to the public telecommunications systems in the United Kingdom.

## Japanese VCCI notice

この装置は、情報処理装置等電波障害自主規制協議会（VCCI）の基準に基づくクラス B 情報技術装置です。この装置は、家庭環境で使用することを目的としていますが、この装置がラジオやテレビジョン受信機に近接して使用されると、受信障害を引き起こすことがあります。

取扱説明書に従って正しい取り扱いをして下さい。

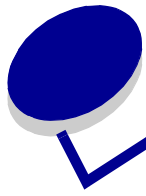

# Glossary

---

**alignment page.** A page with printed alignment patterns that ejects from your printer during cartridge alignment.

**alignment values.** Numbers corresponding to patterns on the alignment page.

**application.** See program.

**automatic alignment.** A feature that automatically aligns the print cartridges.

**cartridge contact.** The gold area on your print cartridge that touches the carrier contacts inside your printer.

**coated paper.** Treated paper designed for high-quality printed images.

**collate.** A printer software option that lets you automatically print one complete copy of a multiple-page document before the next copy begins, and so on.

**configured printer.** A printer connected to a network that has been assigned an IP address and printer name. You must configure a network-capable printer to access it over a network.

**custom size paper.** A non-standard paper size.

**default printer.** The printer automatically used when you send jobs to print.

**default printer settings.** Printer software settings defined when the printer is manufactured.

**driver.** See printer software.

**glossy paper.** Paper with one glossy side designed for photographs.

**handouts.** Multiple-page images printed on a single sheet of paper. See N-up.

**hub.** A device used to connect several computers or peripheral devices.

**IP (Internet Protocol) address.** A 32-bit binary number that identifies the location of a specific computer on the Internet. Any computer directly connected to the Internet must have an IP address.

**label.** Self-adhesive paper.

**landscape orientation.** Page orientation in which text runs parallel with the long edge of the paper.

**Lexmark adapter.** An external device that connects your network-capable printer to a network.

**manual alignment.** A printer software feature that lets you select print cartridge alignment values.

**margin.** The blank area between printed text or graphics and the edges of a page.

**mirror.** A printer software option that lets you reverse an image before printing.

**N-up.** A printer software option that lets you print multiple pages of a document on a single sheet of paper. For example, select 4-up to print reduced images of pages 1 through 4 on the first sheet of paper, images of pages 5 through 8 on the second sheet, and so on.

**natural color.** A printer software option used for printing photographs and highly detailed graphic images.

**network.** A group of computers, printers, or other peripheral devices connected to each other for the purpose of sharing information.

**network adapter.** See Lexmark adapter.

**network printer.** A printer made available on a network, not connected directly to your computer.

**operating system.** The software that provides the basic functions needed for operating your computer. For example, Windows 98 or Macintosh OS X.

**paper type sensor.** A feature that automatically detects some types of paper loaded in the paper tray.

**peripheral device.** Any external device connected to and controlled by a computer.

**photo paper.** Treated paper designed for photographs.

**plain paper.** Paper designed for printing text documents.

**portrait orientation.** Page orientation in which text runs parallel with the short edge of the paper.

**premium paper.** Coated paper designed for reports or documents with graphics.

**print cartridge.** The replaceable unit inside your printer that contains the ink.

**print cartridge nozzles.** The gold area of the print cartridge that ink flows through before it is applied to your paper during printing.

**print queue.** The location on the server where print jobs are stored for printing in the order in which they are sent.

**printer driver.** See printer software.

**printer software.** (1) The program that lets you select settings to customize your print job. (2) The program that lets your computer communicate with your printer.

**program.** Any software loaded on your computer that lets you perform a specific task, such as word processing or photo editing.

**remote subnet.** A separate network that is connected to your local area network.

**reverse order printing.** A printer software option that lets you print the last page of your document first so your pages are in sequential order on the exit tray.

**subnet.** A segment of a network that is connected to a larger network. A local area network is sometimes referred to as a local subnet.

**transparency.** A see-through sheet of print media that can be displayed on an overhead projector.

**USB cable.** A lightweight, flexible cable that lets your printer communicate with your computer. USB cables transmit data at much higher speeds than parallel cables.

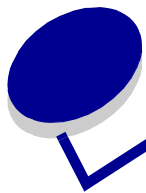

# Index

---

## A

aligning print cartridges 41  
automatic cartridge alignment 41

## B

banding 56  
black cartridge part number 39, 44  
blinking lights 50  
border 11, 31  
borderless cards 22  
borderless photos 18  
button  
    paper feed 7, 50  
    power 7, 50

## C

cable, part number  
    USB 44  
card reader, USB 7  
cards  
    borderless 22  
    printing 20  
cards, memory 7  
cartridges, print  
    aligning 41  
    cleaning 42  
    installing 39  
    ordering 44  
    part number 44  
    preserving 44  
    removing 37  
    replacing 37  
    troubleshooting 45  
    wiping 42  
CD, software  
    installing 48

troubleshooting 46  
characters, misformed 56  
coated paper 18  
color cartridge part number 39, 44  
connector  
    power supply 7  
    USB cable 7  
contacts, wiping 42  
customizing settings  
    cards 21  
    coated paper 17  
    envelopes 24  
    glossy paper 17  
    greeting cards 21  
    handouts 30  
    index cards 21  
    iron-on transfers 32  
    labels 28  
    n-up  
        See handouts  
    photo cards 21  
    photo paper 17  
    plain paper 15  
    postcards 21  
    premium paper 19  
    printer software 9  
    printing color images in black and white 26  
    printing in reverse order 36  
    printing last page first  
        See printing in reverse order  
    transparencies 34  
T-shirt transfers  
    See iron-on transfers

## D

dark or smudged print 55  
default settings 9  
dialog  
    Page Setup 9  
    Print 10  
digital media, photo 7  
downloaded printer driver, installing 48

## E

edge-to-edge printing  
    See borderless cards  
    See borderless photos  
electronic emission notices 59  
envelopes 23  
error messages  
    Ink Low 49  
    Paper Jam 49

## F

FCC notice 59  
flashing lights 49

## G

glossy paper 16  
greeting cards 20

## H

handouts 29

## I

improving print quality 55  
index cards 20  
Ink Low message 49  
installing  
    print cartridges 39



- printer software 47
- intermittent printing 56
- iron-on transfers 31

## L

- labels 26
- last page first, printing 35
- layout 11, 31
- layout, advanced 11, 33, 36
- Lexmark Utility 12
- light
  - paper feed 50
  - power 50
- loading
  - cards 20
  - coated paper
    - See premium paper
  - envelopes 23
  - glossy paper 16
  - greeting cards 20
  - handouts 29
  - index cards 20
  - iron-on transfers 31
  - labels 26
  - photo cards 20
  - photo paper 16
  - plain paper 15
  - postcards 20
  - premium paper 18
  - transparencies 33
  - T-shirt transfers
    - See iron-on transfers

## M

- margins, setting
  - borderless cards 22
  - borderless photos 18
  - minimum settings 56
- memory cards 7
- messages, error
  - Ink Low 49
  - Paper Jam 49
- mirror 11, 33

## N

- network printer
  - configure 14

- troubleshooting 49
- nozzles, print
  - wiping 42
- n-up printing
  - See handouts

## O

- ordering supplies 44
- orientation 10

## P

- page settings, changing 9
- Page Setup dialog 9
- paper exit tray 6
- paper feed button 7
- paper guide 7
- Paper Jam message 49
- paper jam, clearing 54
- paper misfeeds 53
- paper support 7
- Paper Type 11
- paper type sensor 14
- part number
  - black cartridge 39, 44
  - color cartridge 39, 44
  - photo cartridge 39, 44
  - USB cable 44
- photo cards 20
- photo cartridge part number 39, 44
- photo memory cards 7
- photo paper 16
- pop-up menu
  - Color Options 11
  - Copies & Pages 11
  - Document Color 11
  - Format for 10
  - Layout 11
  - Output Options 11
  - Paper Size 10
  - Printer Services 11
  - Quality & Media 11
  - Settings 10
- postcards 20
- power button 7
- power supply
  - connector 7
- premium paper 18

- print cartridge
  - aligning 41
  - cleaning 42
  - installing 39
  - ordering 44
  - part number 44
  - preserving 44
  - removing 37
  - replacing 37
  - wiping 42
- Print dialog 10
- print in reverse order 35
- print last page first
  - See print in reverse order
- print nozzles, wiping 42
- print quality, improving 42
- print quality, troubleshooting 55
- printer cable, troubleshooting 45
- printer driver
  - installing 48
  - removing 47
- printer parts 5
- printer settings, customizing 9
- printer software
  - CD, troubleshooting 46
  - installing 47
  - Lexmark Utility 12
  - overview 9
  - Page Setup dialog 9
  - Print dialog 10
  - removing 47
  - using 9
- printer status 51
- printing
  - alignment page 41
  - borderless cards
  - borderless photos
  - cards 20
  - color images in black and white 25
  - envelopes 23
  - greeting cards 20
  - handouts 29
  - index cards 20
  - iron-on transfers 31
  - labels 26

- last page first
  - See reverse order
- multiple pages per sheet 29
- n-up
  - See handouts
- on premium paper 18
- photo cards 20
- photos 16
- plain paper 15
- reverse order 35
- transparencies 33
- T-shirt transfers
  - See iron-on transfers
- printing problems
  - blank pages 53
  - error messages 49
  - flashing lights 49
  - general 49
  - network 49
  - paper feeding 53
  - paper jams 54
  - print quality 55
  - software 47
  - specialty paper 57
  - unsuccessful or slow printing 51

## R

- release tab, paper guide 7
- removing print cartridges 37
- removing printer software 47
- replacing print cartridges 37

## S

- scale 10
- sensor, paper type 14
- setting margin
  - borderless cards 22
  - borderless photos 18
  - minimum settings 56
- settings, customizing
  - cards 21
  - coated paper 17
  - envelopes 24
  - glossy paper 17
  - greeting cards 22
  - handouts 30
  - index cards 22

- iron-on transfers 32
- labels 28
- last page first
  - See reverse order printing
- n-up
  - See handouts
- photo cards 21
- photo paper 17
- plain paper 15
- postcards 21
- premium paper 19
- printing color images in black and white 26
- reverse order printing 36
- transparencies 34
- T-shirt transfers
  - See iron-on transfers
- settings, default 9
- software, printer
  - CD 46, 48
  - installing 47
  - Lexmark Utility 12
  - removing 47
  - using 9
- specialty paper
  - solving problems with 57
- supplies, ordering 44

## T

- test page
  - does not print 52
  - printing 52
- transfers, iron-on 31
- transparencies 33
- troubleshooting
  - alignment page 52
  - blank pages 53
  - cartridges 45
  - error messages 49
  - flashing lights 49
  - general printing problems 49
  - margins 56
  - network printing 49
  - paper feeding 53
  - paper jams 54
  - paper misfeeds 53
  - print quality 55

- printer cable 45
- printer not printing 51
- printer software installation 47
- software 47
- specialty media 57
- unsuccessful or slow printing 51
- troubleshooting checklist 45

## U

- USB cable
  - connector 7
  - ordering 44
- USB card reader 7
- Utility, Lexmark 12

## W

- Web site, Lexmark
  - offers 13, 48
  - order supplies 11, 13, 44
  - printer software download 47
  - printer software installation 48



Lexmark and Lexmark with diamond design are trademarks of Lexmark International, Inc., registered in the United States and/or other countries. Color Jetprinter and Photo Jetprinter are trademarks of Lexmark International, Inc.

© 2003 Lexmark International, Inc.  
740 West New Circle Road  
Lexington, Kentucky 40550